



Specification:

1. According to : UL507 (PA100A), UL1017 figure 2, figure 6.5 UL1062, UL982 figure 7.1 and figure 1.2 UL474 figure 5.1 and figure 14, UL60065 UL6500 figure 14, Figure 7.2 and figure 8.3 UL1278 UL1082;

2. Mainly used for the inspection to prevent the body touch dangerous live parts, heating or hot parts, mechanical components, as well as inspection of solid foreign bodies into the equipment. It is necessary for protection against electric shock test of household and similar electrical appliances;

3. This is the "UL" test finger, researched and designed by UL and required by most UL Standards. Palm simulator and restricted joint movement simulates human finger movement. Made of all nylon, Bell-Core accessory available. The handle is made of nylon. The finger is made of stainless steel.

Test finger diameter: 25.4mm (1 inch)

Test finger length: 101.6mm (4 inch)

Head radius: R 12.7mm (1/42 inch)

Tail diameter: 31.75mm (1-1/4 inch)

Knurled length: 30/30/40 mm

Material: stainless steel and nylon

Reference: UL507, UL 982, UL 1278, UL 1062, UL1310, UL 474, UL 60065

Figure 9.2
Articulate probe with web stop

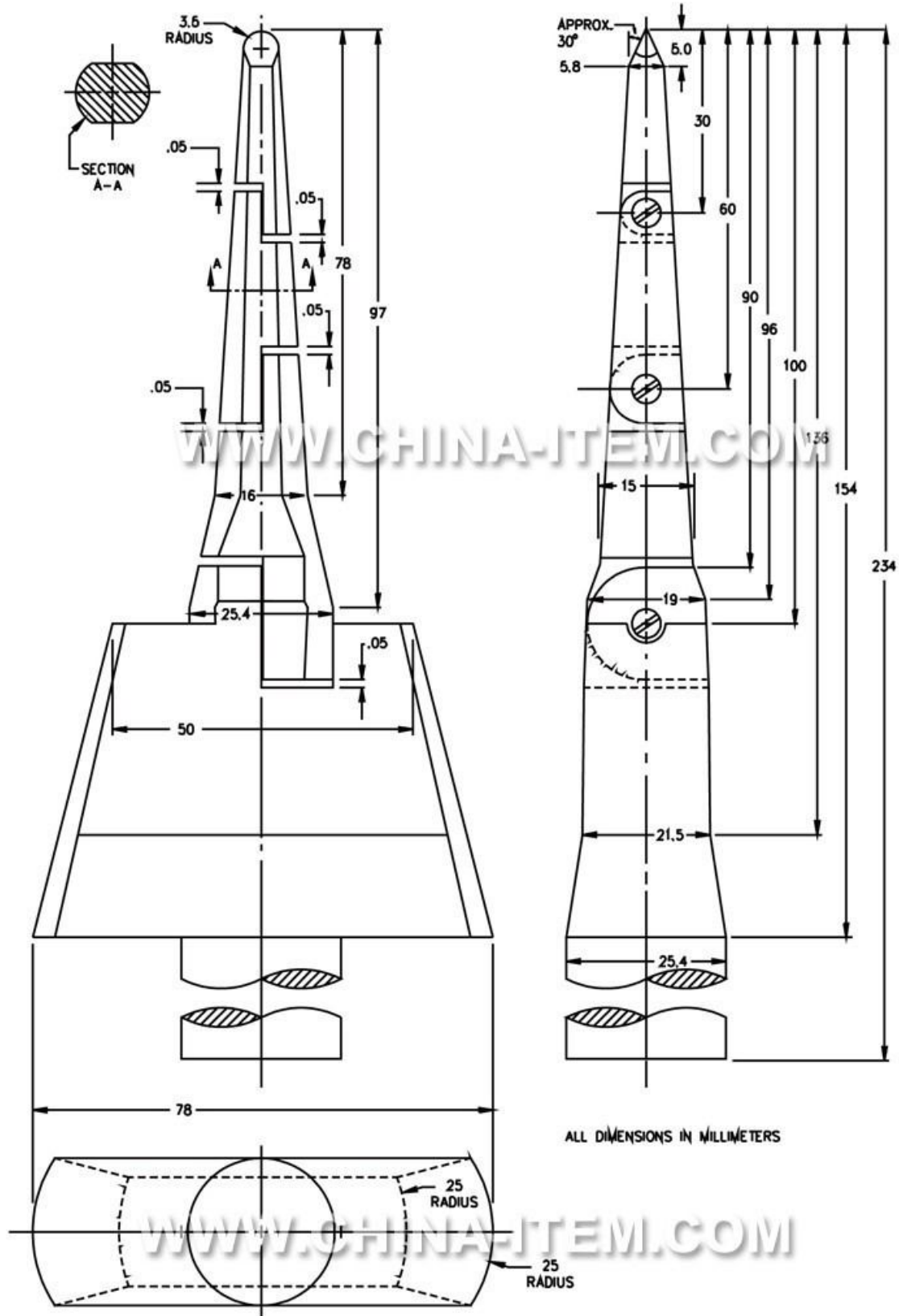

PA100A