

English version

**Household electric cooking appliances -
Part 2: Hobs -
Methods for measuring performance**
(IEC 60350-2:2011, modified)

Appareils de cuisson électrodomestiques -
Partie 2: Tables de cuisson -
Méthodes de mesure de l'aptitude à la
fonction
(CEI 60350-2:2011, modifiée)

Elektrische Kochgeräte für den
Hausgebrauch -
Teil 2: Kochmulden -
Verfahren zur Messung der
Gebrauchseigenschaften
(IEC 60350-2:2011, modifiziert)

This European Standard was approved by CENELEC on 2013-06-03. CENELEC members are bound to comply with the CEN/CENELEC Internal Regulations which stipulate the conditions for giving this European Standard the status of a national standard without any alteration.

Up-to-date lists and bibliographical references concerning such national standards may be obtained on application to the CEN-CENELEC Management Centre or to any CENELEC member.

This European Standard exists in three official versions (English, French, German). A version in any other language made by translation under the responsibility of a CENELEC member into its own language and notified to the CEN-CENELEC Management Centre has the same status as the official versions.

CENELEC members are the national electrotechnical committees of Austria, Belgium, Bulgaria, Croatia, Cyprus, the Czech Republic, Denmark, Estonia, Finland, Former Yugoslav Republic of Macedonia, France, Germany, Greece, Hungary, Iceland, Ireland, Italy, Latvia, Lithuania, Luxembourg, Malta, the Netherlands, Norway, Poland, Portugal, Romania, Slovakia, Slovenia, Spain, Sweden, Switzerland, Turkey and the United Kingdom.

CENELEC

European Committee for Electrotechnical Standardization
Comité Européen de Normalisation Electrotechnique
Europäisches Komitee für Elektrotechnische Normung

Management Centre: Avenue Marnix 17, B - 1000 Brussels

Foreword

This document (EN 60350-2:2013) consists of the text of IEC 60350-2:2011 prepared by IEC/SC 59K "Ovens and microwave ovens, cooking ranges and similar appliances", of IEC/TC 59 "Performance of household and similar electrical appliances", together with the common modifications prepared by CLC/TC 59X "Performance of household and similar electrical appliances".

The following dates are fixed:

- latest date by which this document has to be implemented at national level by publication of an identical national standard or by endorsement (dow) 2014-06-03
- latest date by which the national standards conflicting with this document have to be withdrawn (dow) 2016-06-03

Together with EN 60350-1:2013, this document will supersede EN 50304:2009/EN 60350:2009 + A1:2010/A11:2010.

EN 60350-2:2013 includes the following significant technical changes with respect to EN 50304:2009/EN 60350:2009:

- 1) a method to measure energy consumption of hobs
 - a) that is representative for a real cooking process, for which after the heat up phase a simmering phase has been implemented in the measurement. Water as a standardised load is used. Food is theoretically considered in the experimental setup but not used as that leads to insufficient reproducibility. The ranking between the technologies will not be changed by different methods/applications, so the energy consumption is measured only by one energy optimised method.
 - b) that is applicable to compare different electrically heated technologies like e.g. induction, radiant or solid plates
 - c) that leads not to a comparison with gas burners. Gas hobs are covered by EN 30-2-1.
 - d) that fulfil requirements of repeatability and reproducibility (crucial for energy measuring purposes). Therefore the cooking process is defined on the temperature level 90 °C to avoid influence on the boiling point by ambient pressure.
 - e) that is applicable for hobs with different layouts and **cooking zone** / area sizes.

This method is based on the method described in TC59X/217/DC.

- 2) definition of cooking areas:

Following new market trends a definition for cooking areas is given. A definition is necessary as cooking areas have other demands e.g. for positioning the cookware or selecting the cookware sizes than **cooking zones**.

- 3) definition of standardised cookware also for big **cooking zone** sizes:

For a high reproducibility a standardised cookware shall be used. Therefore a self made cookware is defined up to a size of 330 mm bottom diameter. Evaporating water by holes in the lid simulates a cooking process on a higher temperature level. The thermal energy which is needed to keep at boiling point for a real cooking process including evaporation and the energy uptake of the food during the simmering phase is considered by the holes.

- 4) additional requirements (according to EN 50564) how to measure low power modes.

5) under consideration:

A control procedures for checking measured values in comparison to values declared by the manufacturer under consideration of permitted tolerances. WG10 with the support and sponsorship of CECED believes that it is fundamental to proceed with a Round Robin Test procedure of this draft amendment to confirm requirements of repeatability and reproducibility and to estimate the standard deviation of the method itself.

Clauses, subclauses, notes, tables, figures and annexes which are additional to those in IEC 60350-2:2011 are prefixed "Z".

Words in **bold** in the text are defined in Clause 3.

According to the decision D137/061 for CLC/TC 59X, this European Standard has been drawn up as a document which follows, as far as suitable, the structure of IEC 60350-2:2011.

It also describes the evaluation of data declared by the manufacturer and control procedures for checking these values.

This document has been prepared under a mandate given to CENELEC by the European Commission and the European Free Trade Association.

This European Standard is suitable for direct comparison and is considered sufficiently reproducible within given limits for the purpose of setting the ecodesign requirements for hobs according to the Directive ERP 2009/125/EC.

Endorsement notice

The text of the International Standard IEC 60350-2:2011 was approved by CENELEC as a European Standard with agreed common modifications.

COMMON MODIFICATIONS

General

Replace all “hotplates” by “cooking zones” except “solid hotplates” and “tubular hotplates”.

2 Normative references

Replace IEC 62301:2005 by

EN 50564:2011, *Electrical and electronic household and office equipment – Measurement of low power consumption (IEC 62301:2011, mod.)*

Add the following references:

HD 60364-5-54, *Low-voltage electrical installations – Part 5-54: Selection and erection of electrical equipment – Earthing arrangements and protective conductors (IEC 60364-5-54)*

EN ISO 80000-1:2013, *Quantities and units – Part 1: General (ISO 80000-1:2009 + Cor 1:2011)*

EN 10088-2, *Stainless steels — Part 2: Technical delivery conditions for sheet/plate and strip of corrosion resisting steels for general purposes*

3 Terms and definitions

Replace definitions 3.2 and 3.3 by:

3.2

hob

appliance or part of an appliance which incorporates one or more **cooking zones** and/or **cooking areas** including a **control unit**

Note 1 to entry: A **hob** is also known as a cooktop.

Note 2 to entry: The **control unit** can be included in the **hob** itself or integrated in a **cooking range**.

3.3

cooking zone

cooking zone has limitative markings on the surface of a **hob** or attached to it where cookware is placed and heated

Note 1 to entry: **Cooking zones** which are used without cookware but by positioning the food directly on the surface are not included.

Note 2 to entry: A **cooking zone** can be

- **single zone and multiple zones** (see 3.3.Z1);
- a **solid hotplate** (see 3.3.Z2);
- a **tubular hotplate** (see 3.3.Z3);
- a **radiant cooking zone** (see 3.3.Z4);
- a **induction cooking zone** (see 3.3.Z5).

Add the following new definitions:

3.3.Z1

single zone and multiple zones

cooking zone marked as **single zone** for one cookware size or as **multiple zones** for more than one cookware size and shape

Note 1 to entry: A **multiple zone** can be circular, elliptical or a combination.

Note 2 to entry: An example for the design of a multiple zones is shown in Annex ZD.

3.3.Z2

solid hotplate

cooking zone having a closed surface which is usually constructed from cast iron with an integrated heating element

3.3.Z3

tubular hotplate

cooking zone having a surface which is formed by the configuration of a tubular heated heating element in a substantially flat plane

3.3.Z4

radiant cooking zone

cooking zone on which the pan is heated by means of a radiant heating element below the glass ceramic. Heater could have a heating ribbon, heating spiral or a tungsten wire which is located in a quartz glass bulb or combination of these

3.3.Z5

induction cooking zone

cooking zone on which the pan is heated by means of an induction element below the glass ceramic or similar. The eddy currents are inducted in the bottom of the pan by magnetic field

Delete definitions 3.4 to 3.8.

Add the following new definitions:

3.Z1

cooking area

area heated by an inducted magnetic field where cookware is placed for heating, and that can be

- an area where no clear limitative markings for cookware are visible on the surface of the **hob** or
- an area marked to show the limits where more than one cookware can be used simultaneously. The cookware pieces can be used and controlled separately from each other at the same time. Additionally the **cooking area** can be used combined for one cookware

Note 1 to entry: The **cooking area** could be also used combined for one big cookware piece even if there is more than one **control**.

Note 2 to entry: **Cooking areas** which are used without cookware but by positioning the food directly on the surface are not included.

Note 3 to entry: There could be a decoration symbol, e.g. a cross on the surface to mark the centre of the **cooking area**.

3.Z2

control

control is a part of the **hob** independent from technical solution (e.g. knobs, touch **controls** etc). The power and the temperature respectively of the **cooking zone** or **cooking area** can be adjusted by the **control** for one piece of cookware

Note 1 to entry: The power is generally indicated as numbers, but also temperature values and symbols are possible. The **control** can also be outside of the **hob** integrated in a separate device or part of a built-in-oven.

3.Z3

warming zone

warming zone is used for keeping food warm. Its intention for use is not cooking

Note 1 to entry: Normally one power setting exists – on and off.

3.Z4**maximum power**

maximum possible power setting if only one cookware is used

Note 1 to entry: Boost function is considered

3.Z5**set to off mode**

action where the product is switched off using appliance **controls** or switches that are accessible and intended for operation by the user during normal use to attain the lowest power consumption that may persist for an indefinite time while connected to a main power source and used in accordance with the manufacturer's instructions

Note 1 to entry: All actions required to set to off mode like for example remove the cookware etc have to be taken.

Note 2 to entry: For definition of off mode, EN 50564:2011 is relevant.

3.Z6**set to standby mode**

action where the product is switched to standby using appliance **controls** or switches that are accessible and intended for operation by the user during normal use to attain the lowest power consumption that may persist for an indefinite time while connected to a main power source and used in accordance with the manufacturer's instructions

Note 1 to entry: For definition of standby mode, EN 50564:2011 is relevant.

4 List of measurements**4.1 Dimensions and mass**

Replace the second, third and fourth dash items by the following:

- cooking zones per hob (see 6.2);
- level of solid hotplates (see 6.3)
- distance between the cooking zones (see 6.4);

4.2 Hotplates and cooking zones

Replace the title of 4.2 by "Cooking zones and cooking areas".

Replace the first and second dash items by the following:

- energy consumption and time for heating (see 7.1 and Annex ZA).

5 General conditions for the measurements

Add the following just after the title:

5.Z1 Introduction

Unless otherwise specified, the measurements are made under the following conditions.

If numbers have to be rounded, they shall be rounded to the nearest number according to EN ISO 80000-1:2013, B.3, Rule B. If the rounding takes place to the right of the comma, the omitted places shall not be filled with zeros.

5.1 Test room

Replace the text by:

The tests are carried out in a substantially draught-free room in which the laboratory ambient temperature is maintained at $(20 \pm 5) ^\circ\text{C}$.

For test 7.1, $(23 \pm 2) ^\circ\text{C}$ shall be maintained during the complete test.

This ambient temperature is measured at a point that is at the same height as the hob positioned at working height and at a distance of 0,5 m diagonally from one of the front edges of the appliance,

NOTE The working height is between 800 mm and 1 000 mm normally.

The measurement of the ambient temperature shall not be influenced by the appliance itself or by any other appliance.

The absolute air pressure shall be 913 hPa to 1 063 hPa.

5.2 Electricity supply

Add the following before the note:

For test 7.1, the supply voltage shall be maintained at the main terminal at $230 \text{ V} \pm 1 \%$ or at $400 \text{ V} \pm 1 \%$ as defined by the manufacturer's installation guide, while the heating elements are switched on. The supply frequency shall be at a nominal $50 \text{ Hz} \pm 1 \%$.

The supply voltage shall be essentially sinusoidal.

5.3 Instrumentation

Replace the whole subclause by:

5.3 Instruments and measurements

Instruments used and measurements made for this document shall comply with the following specifications.

Table Z1 – Instruments

Parameter	Unit	Minimum resolution	Minimum accuracy	Additional requirements
Mass (7.1)	g	0,5 g	$\leq 1\,000 \text{ g} \pm 1 \text{ g}$ $> 1\,000 \text{ g} \pm 3 \text{ g}$	
Temperature				
– ambient temperature	$^\circ\text{C}$	0,1 $^\circ\text{C}$	$\pm 1 \text{ K}$	
– temperature, water load (7.1)	$^\circ\text{C}$	0,1 $^\circ\text{C}$	$\pm 0,5 \text{ K}$	3 mm steel tube
Time	s	1 s	$\pm 1 \text{ s}$	
Energy	Wh	-	$\pm 1 \%$	Very quick electronic on/off periods shall be taken into account by measurement techniques.
Air pressure	hPa	1 hPa	$\pm 1 \%$	

Table Z2 – Measurements

Parameter	Unit	Minimum resolution	Minimum accuracy	Additional requirements
Voltage	V	-	± 0,5 %	-
Temperature and energy consumption measurement (7.1)		-	-	sampling rate 1 Hz (digital measurement data)
For Clause 8, the power measurement requirements shall be in accordance with EN 50564		-	-	According to EN 50564

NOTE The required accuracy of temperature measurement in the water load (7.1) can be fulfilled by calibrating temperature measurement or for instance by a PT100 according to EN 60751.

5.5 Setting of controls

Replace the whole subclause by:

5.5 Initial conditions

The appliance shall be at laboratory ambient temperature at the beginning of each test.

Forced cooling may be used to assist in reducing the temperature.

6 Dimensions and mass

6.2 Dimensions of hotplates and cooking zones

Replace the whole subclause by:

6.2 Cooking zones per hob

6.2.Z1 Number of cooking zones per hob

The number of **cooking zones** is determined by the maximum number of **controls** which can be operated independently all at the same time.

The number of **controls** per **hob** is noted.

6.2.Z2 Dimensions of cooking zones

The main dimensions are determined as follows.

The main dimensions of **cooking zones** are determined by measuring the marked area on the surface. For circular **cooking zones**, the diameter of the largest marked circle is measured.

For **multiple zones**, the dimension for each size is measured.

For **solid hotplates**, the diameter of the surface intended to come into direct contact with the bottom of saucepans is measured.

For **tubular hotplates**, the diameter of the largest periphery excluding any leading section is measured.

If the **cooking zones** are not circular, the dimensions are determined as follows:

- for rectangular and similar shapes, the lengths of the sides are measured;
- for elliptical and similar shapes, the major and minor dimensions are measured.

NOTE The dimension of a radiant or induction **cooking zone** is determined by the printing on the surface independent from the size of heating element.

The dimensions are indicated in millimetres.

6.3 Level of hotplates

Replace the title of 6.3 by “Level of solid hotplates”.

Replace all “hotplates” in 6.3 to “solid hotplates”.

6.4 Distance between hotplates and cooking zones

Replace the title of 6.4 by “Distance between cooking zones”.

Delete all “hotplates” in 6.4.

7 Hotplates and cooking zones

Replace the title of Clause 7 by “Cooking zones and cooking areas”.

Add the following new subclause just after the title:

7.21 General

The tests described in Clause 7 are applicable to **cooking zones** with a diameter ≤ 330 mm and ≥ 100 mm or one of the sides' length ≤ 330 mm and ≥ 100 mm.

In addition, tests are applicable to **cooking areas**. Further requirements concerning **cooking areas** are described in Annex ZA.

For **multiple zones** which include a circular and an elliptical or rectangular part, only the circular part is tested.

7.1 Ability to heat water

Replace the whole subclause by:

7.1 Energy consumption and heating up time

7.1.Z1 Purpose

The purpose is to assess the heating up time of a defined water load. In a second measurement, the energy consumption for heating up a defined water load and keep it at a defined temperature level for 20 min is determined.

NOTE 1 Heating up and keeping the temperature for a defined period represents a typical household cooking process. Additionally the quality of control is measured by keeping an amount of water at a defined temperature as exactly as possible.

NOTE 2 The simmering time of 20 min represents an average household cooking duration. Additionally at least 20 min further simmering time is necessary to assess the quality of a **control** which influences the energy consumption.

7.1.Z2 Cookware and water amount

Standardised cookware with lid as specified in Figure Z1 is used for 7.1.

Hobs working exclusively with system cookware and not with household like cookware shall be tested with its system cookware, but the system cookware shall be covered with the lid according to Table Z3.

The material of the cookware bottom is stainless steel 1.4016 according to EN 10088-2, the thickness is $6 \text{ mm} \pm 0,05 \text{ mm}$. The surface shall not be shiny.

The flatness of the bottom plate is specified in Table Z3 for different sizes. Convex shaped bottom plate is not allowed. The flatness of the base has to be checked before starting a measurement.

For the side wall, 1.4301 stainless steel according to EN 10088-2 with $1 \text{ mm} \pm 0,05 \text{ mm}$ thickness shall be used. The cookware is cylindrical without handles or protrusions.

As the dimensions and material of cookware and lid influence the performance, only the cookware specified in Figure Z1, including the lid, shall be used.

The lid is made of aluminium, thickness is $2 \text{ mm} \pm 0,05 \text{ mm}$. The dimensions for the lid are fixed in Table Z3. Each hole on the hole circle of the lid has a diameter of $16 \text{ mm} \pm 0,1 \text{ mm}$. The holes shall be evenly distributed on the hole circle.

The lid, which is flat, is adapted to accommodate a temperature sensor in the centre. The temperature sensor is positioned 15 mm above the inner cookware bottom.

In order to reduce measurement noise generated by the electromagnetic field of an **induction cooking zone**, the lid of the cookware shall be connected to ground through a clamp (see Figure Z1, d)). The ground connection of the electric installation of the testing laboratory shall be according to HD 60364-5-54.

NOTE 1 A wire of 2 mm^2 of section and maximum length of 2 m is welded to the metallic clamp and ends in connection box which is joined to a plug connector.

NOTE 2 A supplier for the stainless steel 1.4016 and for the cookware is indicated in B.Z1 and B.Z2.

NOTE 3 The sidewalls of the cookware can be built up of a metal sheet. The metal sheet is rolled and welded to a sheet-metal jacket. The sidewalls can additionally fixed by three welding points to the bottom. The requirements for flatness have to be fulfilled afterwards.

NOTE 4 An example how to fix the temperature sensor to the lid is shown in Annex ZB.

NOTE 5 Evaporating water by holes in the lid simulates a cooking process on a higher temperature level. The thermal energy which is needed to be at the boiling point for a real cooking process including evaporation and the energy uptake of the food during the simmering phase is considered by the holes.

The following standardised cookware sizes are defined.

Table Z3 – Sizes of standardised cookware and water amounts

Diameter of the cookware bottom (outside)	Diameter of the lid	Lid hole circle diameter	Number of holes on the circle	Total cookware height (outside)	Flatness of cookware bottom	Water load	Cooking zone size category	Standardised cookware categories
mm	mm	mm		mm	mm	g	mm	
120 ± 0,5	130 ± 1	80 ± 1	7	125 ± 0,5	≥ 0 < 0,075	650	≥ 100 < 130	A
150 ± 0,5	165 ± 1	110 ± 1	11	125 ± 0,5	≥ 0 < 0,075	1 030	≥ 130 < 160	
180 ± 0,5	200 ± 1	140 ± 1	16	125 ± 0,5	≥ 0 < 0,075	1 500	≥ 160 < 190	B
210 ± 0,5	230 ± 1	170 ± 1	22	125 ± 0,5	≥ 0 < 0,1	2 050	≥ 190 < 220	C
240 ± 0,5	265 ± 1	200 ± 1	29	125 ± 0,5	≥ 0 < 0,1	2 700	≥ 220 < 250	
270 ± 0,5	300 ± 1	230/210 ^a ± 1	18/18 ^a	125 ± 0,5	≥ 0 < 0,15	3 420	≥ 250 < 280	D
300 ± 0,5	330 ± 1	260/210 ^a ± 1	23/22 ^a	125 ± 0,5	≥ 0 < 0,15	4 240	≥ 280 < 310	
330 ± 0,5	365 ± 1	290/270 ^a ± 1	27/27 ^a	125 ± 0,5	≥ 0 < 0,15	5 140	≥ 310 ≤ 330	

^a Number of holes are arranged on two hole circles.

NOTE 6 Standardised cookware categories are only relevant for cookware defined in Table Z3. Categories are necessary to make sure that different cookware sizes – as relevant in a household – are considered.

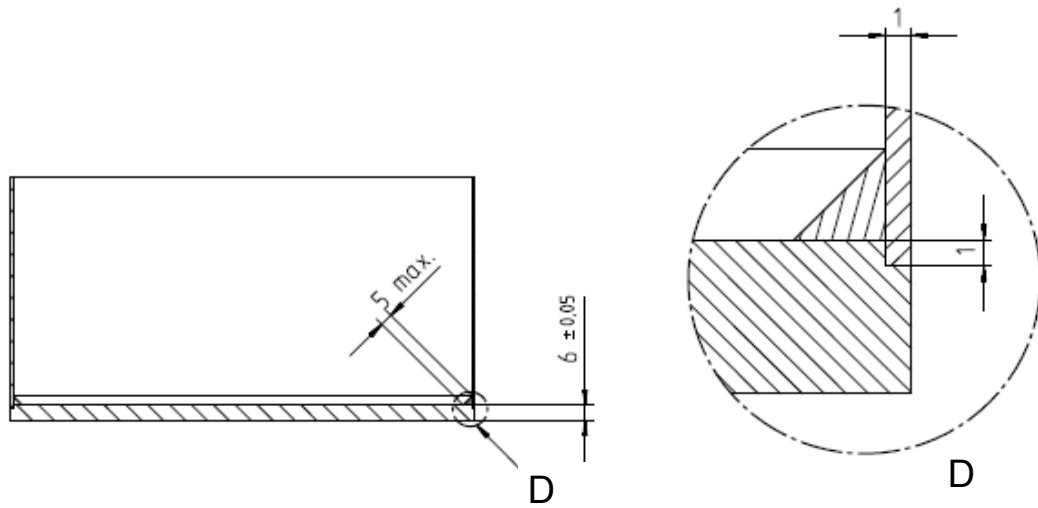
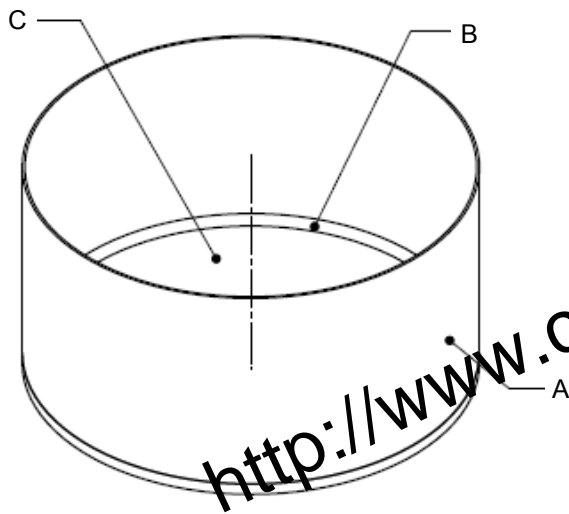

Key

- A side wall
- B glue heat resistant
- C bottom plate
- D detail of the edge

a) Example for cookware size of 180 mm diameter

Dimensions in millimetres

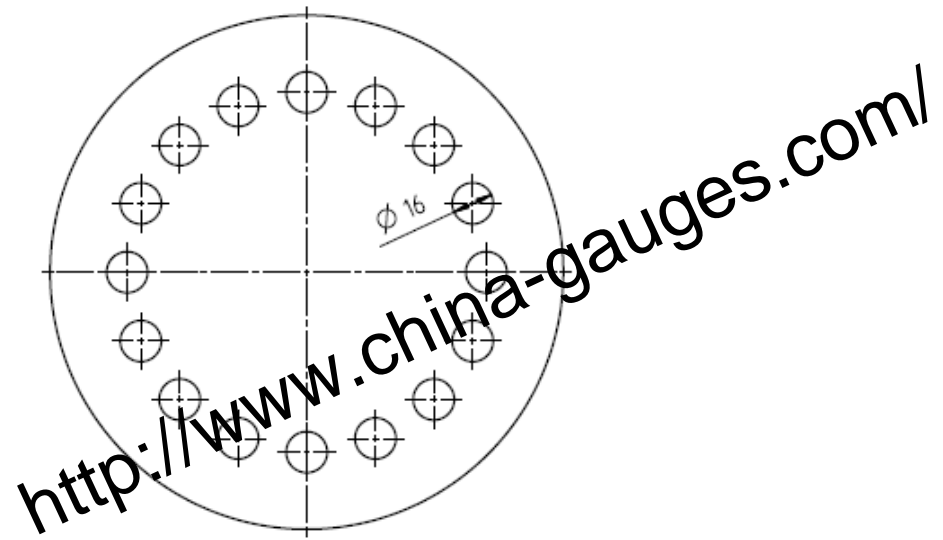

b) Example lid for Ø 180 mm cookware

Dimensions in millimetres

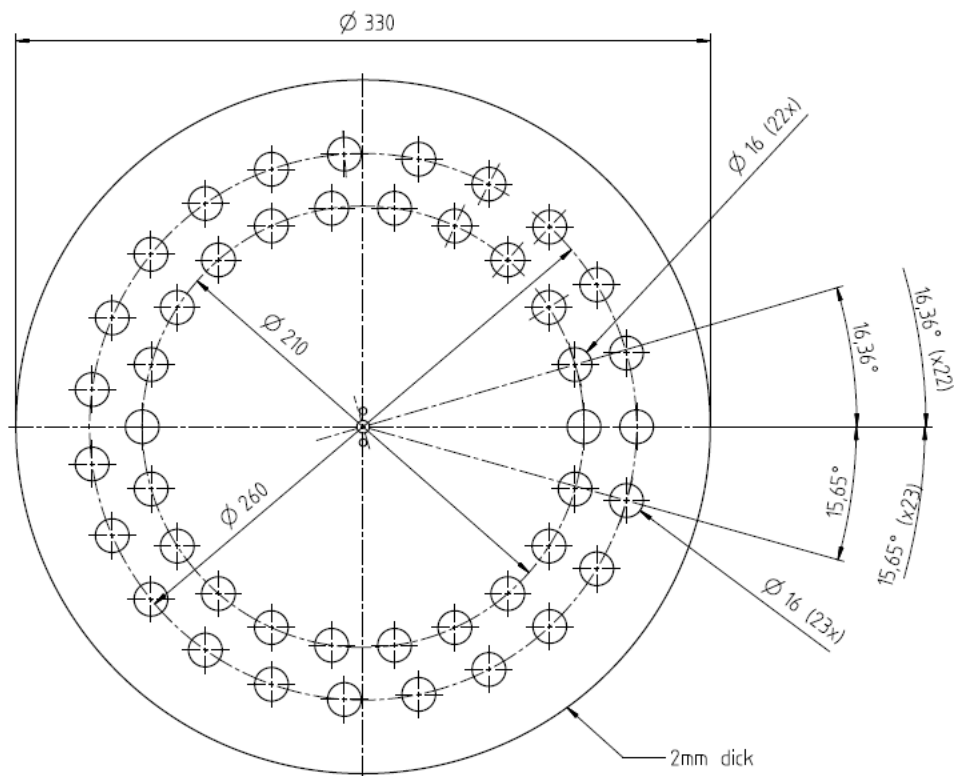

c) Example lid for Ø 300 mm cookware"

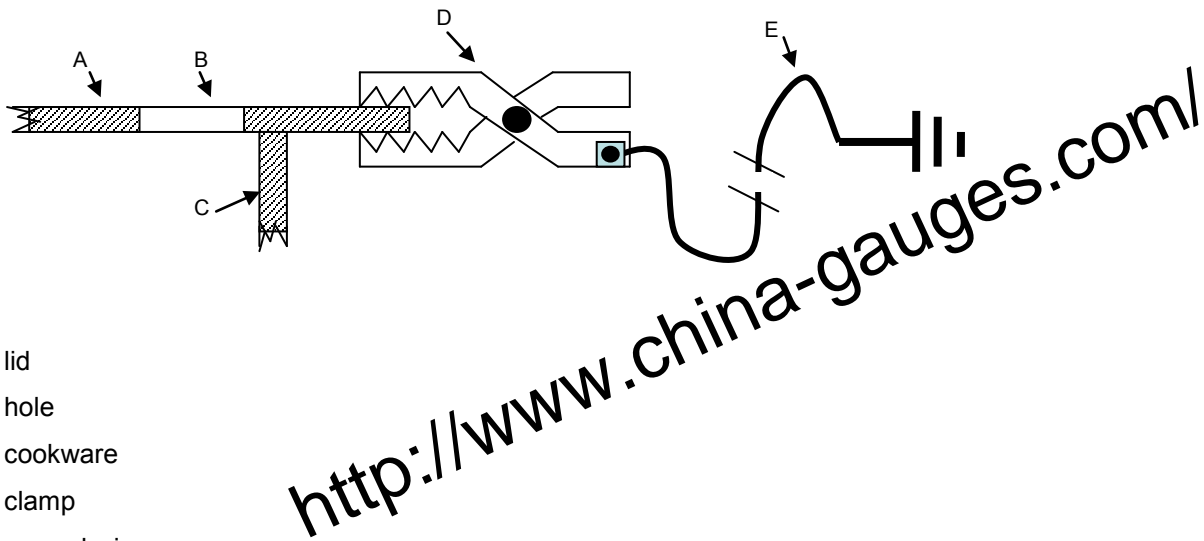

Key

- A lid
- B hole
- C cookware
- D clamp
- E ground wire

d) Ground connection

Figure Z1 – Cookware to determine energy consumption and heating up time

7.1.Z3 Determine a cookware set to assess a hob with cooking zones

The number of pieces of cookware needed to assess a **hob** shall correspond to the number of **controls** which can be used simultaneously and independently.

For selecting sizes and number of cookware pieces, see Table Z4.

Table Z4 – Criteria for cookware set – Cooking zones

Number of cookware used for tests according to 7.1	Criteria for cookware set for cooking zones
1	From one standardised cookware category according to Table Z3 that is equal to the dimensions of the cooking zone or best fit.
2	At least from one standardised cookware category according to Table Z3 that are equal to the dimensions of the cooking zones or best fit.
3	At least from two standardised cookware categories according to Table Z3 that are equal to the dimensions of the cooking zones or next best fit cookware category.
4 or more	At least from three standardised cookware categories according to Table Z3 that are equal to the dimensions of the cooking zones or next best fit cookware category.

For circular **multiple zones**, the biggest diameter determined according to 6.2.Z2 is considered.

For non circular **cooking zones**, the cookware size is determined by the short axis measured according to 6.2.Z2.

If on an induction **hob** cookware is not detected, the next bigger cookware diameter is chosen independent from the cookware category.

If a standardised cookware category A-D has to be substituted, the next best fitting cookware is selected. The cookware with the closest bottom diameter compared to the **cooking zone** diameter is chosen.

Hereby cookware can be smaller or bigger than the **cooking zone**. Therefore also smaller diameter of **multiple zones** can be considered. Each **cooking zone** is taken into account only once. The one with the closest diameter to the **cooking zone** is the best fitting cookware size.

If a selected cookware size is out of the range of the sizes allowed by the user manual, then the closest diameter compatible with the defined range has to be chosen.

If it is not clear which cookware size is best fitting, all possibilities are assessed.

NOTE As mentioned in 7.Z1 for **multiple zones** which include a circular and an elliptical or rectangular part, only the circular part is tested.

7.1.Z4 Positioning the cookware on a cooking zone

On a **cooking zone**, the cookware is used in the centre.

The centre of an elliptical or similar shaped **cooking zone** is determined in the intersection of the shortest and longest axis.

The centre of a rectangular or similar **cooking zone** is determined in the intersection of the two diagonals.

If two **cooking zones** with the same size are available and cookware pieces with different sizes have to be placed there, then the selection for the bigger cookware size will be made in accordance with the following order of precedence:

- a) **cooking zones** having higher **maximum power**;
- b) **cooking zones** being located at the rear of the **hob**;
- c) **cooking zones** being located at the left.

7.1.Z5 Procedure for measuring the heating up time

Before this measurement is done, the **hob** has to be operated for at least 10 min to make sure that residual water in the components is vaporised.

For this measurement, only one **control** with one cookware shall be switched on.

The cookware is filled with the quantity of potable water specified in Table Z3. The water has a temperature of $15\text{ °C} \pm 0,5\text{ °C}$. The cookware covered with the lid is positioned centrally on the **cooking zone** or **cooking area**.

The **cooking zone** or **cooking area** is heated with **maximum power**.

NOTE 1 If the smaller diameter of **multiple zones** is considered, the corresponding power is used.

The time taken for the water temperature to rise by 75 K is measured. The test is performed three times.

The average value of the results is determined.

The time is stated in minutes, rounded to the nearest ten seconds.

NOTE 2 Energy consumption can be measured for comparative tests. Residual heat is not taken into account in this case.

7.1.Z6 Procedure for measuring the energy consumption of a cooking process

7.1.Z6.1 General

Before this measurement is done, the **hob** has to be operated for at least 10 min to make sure that residual water in the components is vaporized.

For this measurement, only one **control** with one cookware shall be switched on.

The appliance shall be at ambient temperature.

The empty cookware, which shall have ambient temperature, is filled with the quantity of potable water specified in Table Z3 and stirred. The temperature of water is measured when the average temperature of cookware and water has stabilised. The initial temperature shall be in the range of $15\text{ °C} \pm 0,5\text{ °C}$ (T_{15}). The cookware covered with the lid is immediately positioned centrally on the **cooking zone** or **cooking area**.

The measurement shall start immediately after placing the cookware on the **cooking zone** or **cooking area**. The power **control** is set to **maximum power**.

NOTE 1 Water having an initial temperature of $14,5\text{ °C}$ minimise the stirring time.

NOTE 2 The filled cookware should not be stored in the fridge to avoid the rims getting too cold.

NOTE 3 If the smaller diameter of **multiple zones** is considered the corresponding power is used.

7.1.Z6.2 Preliminary measurements

7.1.Z6.2.1 General

Preliminary tests are carried out to determine the appropriate water temperature for reducing the power setting (T_c) and to determine the lowest level to set to achieve $\geq 90\text{ °C}$ during the remaining cooking period.

7.1.Z6.2.2 Determine T_c

The procedure described in 7.1.Z6 shall be followed.

The power shall be switched off when the water temperature reaches 70 °C (T_{70}).

The temperature rising is recorded continuously. The highest temperature value is stated as temperature overshoot (ΔT_o), see Figure Z2.

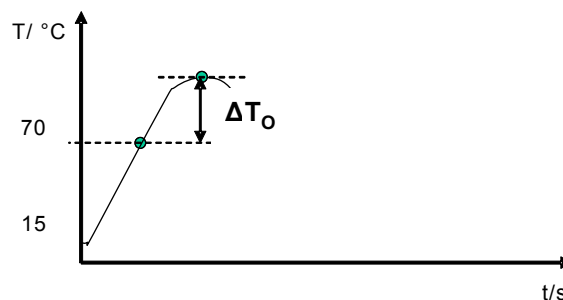

Figure Z2 – Overshoot measurement

NOTE 1 For ΔT_o , the value stated on the temperature measuring instrument is taken.

To get a higher accuracy the temperature T_{70} is determined by the average of the recorded temperature between $t_{70} - 10\text{ s}$ and $t_{70} + 10\text{ s}$. If the result is within the tolerance of $70\text{ °C} \pm 0,5\text{ °C}$ then this temperature is noted. If not, the test is repeated.

T_c is calculated according to the following formula:

$$T_c = 93\text{ °C} - \Delta T_o$$

where T_c is rounded to the nearest integer.

In case the temperature limiter of a **radiant cooking zone** is switching down, the power during the to period, a 2 K higher T_c is allowed.

If the calculated T_c is $\leq 80\text{ °C}$, then 80 °C is taken as T_c .

T_c , the temperature for reducing the power setting, is stated.

NOTE 2 Empirical tests show similar T_c values per **induction cooking zones** and **cooking areas**, **radiant cooking zones** and solid plates. The following values are representative and they can substitute the result of 7.1.Z6.2.2 as fixed values:

- **induction cooking zones** and **cooking areas** $T_c = 89\text{ °C}$;
- **radiant cooking zones** $T_c = 85\text{ °C}$;
- solid plate $T_c = 80\text{ °C}$.

7.1.Z6.2.3 Determine simmering setting

The procedure stated in 7.1.Z6 is followed.

If T_c is reached, the setting is reduced to achieve the water simmering at a temperature $\geq 90\text{ °C}$ and as close as possible to 90 °C . An additional change of setting is not allowed. For T_c , the tolerances are $+1,0\text{ K}$ to $-0,5\text{ K}$.

At first, the lowest simmering setting is selected. If the temperature of the water is $< 90\text{ °C}$ during the simmering time, the test has to be repeated with an increased power setting.

When the water temperature reaches 90 °C for the first time (T_{90}), the simmering time starts independent from T_c .

The simmering time is 20 min.

The lowest possible simmering power setting is noted.

For **control** units without detent, the knob position should be marked. The simmering setting could differ if a knob is turned from a higher position to a lower position compared to turning from a lower position to a higher position.

NOTE For a clear marking of the lowest possible simmering power setting, a polar coordinate paper can be useful (see Annex ZB).

7.1.Z6.3 Measuring energy consumption

The procedure stated in 7.1.Z6 is followed. The results from 7.1.Z6.2.2 and 7.1.Z6.2.3 are applied. After finishing, the appliance is **set to off mode**. If the appliance doesn't offer an off mode, it is **set to standby mode**.

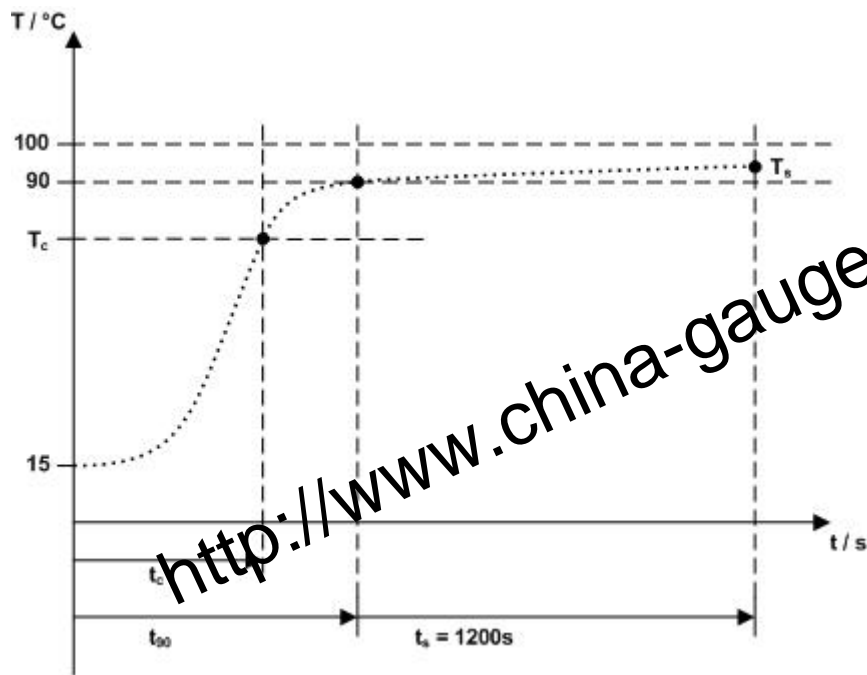

where

t_{90} is the time when 90 °C is reached and simmering period starts [s];

t_c is the time when power setting is reduced [s];

t_s is the simmering time [s];

T_c is the water temperature when setting is reduced [°C];

T_s is the water temperature at the end of the process [°C].

Figure Z3 – Energy consumption measurement process for the active mode of one cookware

The following data shall be recorded:

- the energy consumption after 20 min simmering time in kWh for the energy consumption measurement process;
- t_c and t_{90} in minutes and seconds;
- initial temperature of water, T_c and T_s of the water in °C;
- average power needed to achieve t_s in W;
- ambient temperature in °C at the start of the test (when the **hob** is switched on) and at the end of the test (after 20 min simmering time);
- relative air pressure at the start of the test and at the end of the test in hPa.

The test is performed three times if the **hob** is tested only with one or two cookware pieces.

NOTE The energy consumption of components such as fans and displays, which are automatically switched on with the appliance, are included in the measurement.

7.1.Z7 Evaluation and calculation

7.1.Z7.1 General

The single results according to 7.1.Z5 and 7.1.Z6 are determined for a **hob** as following.

7.1.Z7.2 Energy consumption for a hob

The energy consumption E_{hob} is calculated as followed:

- the result of each cookware is normalised to 1 000 g of water; the energy consumption is divided by the quantity of water used for the cookware under test;
- the average of the normalised energy consumption of the hob is calculated considering all cookware pieces under test.

$$E_{\text{hob}} = \frac{1000\text{g}}{n_{\text{cw}}} \times \sum_{\text{cw}=1}^{n_{\text{cw}}} (E_{\text{cw}} / m_{\text{cw}})$$

where

E_{hob} is the energy consumption of a **hob** calculated per 1 000 g, in Wh;

E_{cw} is the energy consumption with a single cookware under test, in Wh;

m_{cw} is the quantity of water used for the test of the cookware pieces, in g;

n_{cw} is the number of cookware pieces on the **hob**.

As an example for data and calculation sheet, see Annex ZE. An Excel 97-2003 evaluation program, which corresponds directly to Annex ZE, is available with this European Standard for the automatic calculation of the energy consumption (see 7.1.Z6). These calculations may be made in any other spreadsheet programs that lead to equal results.

7.1.Z7.3 Measurement uncertainty of results – Energy consumption for a hob

The energy consumptions E_{hob} determined according to 7.1.Z6 shall not be greater than the value declared by the manufacturer plus 10 % plus 0,015 kWh.

If the result of the test carried out on the first appliance is greater than the declared value plus 10 % plus 0,015 kWh, the test shall be carried out on a further three appliances, which shall be randomly selected from the market.

The arithmetical mean of the values of these three appliances shall not be greater than the declared value plus 6 % plus 0,015 kWh.

7.3.1 General

Specification of the frying pan

Delete hotplate in the 4th line of this subclause. ("less than the diameter of the hotplate or cooking zone...")

8 Standby power

Replace the whole Clause 8 by the following:

8 Consumption measurement of low power modes

In addition to EN 50564, the following requirements are given.

For an appliance composed of a combination of separate units which may consist of one of a variety of different **hobs** and one of a variety of different ovens, the recommended combination as declared in the manufacturer's instruction is used for the test.

If appliance A (e.g. **hob**) can only be operated combined with appliance B (e.g. oven), first the low power mode for appliance B without appliance A is measured and noted. Afterwards, the low power mode for the appliance B combined with the appliance A is measured. The low power consumption of appliance A is calculated by the difference between these two measurements.

When preparing the test report for an appliance composed of a combination of separate units, the combination of types of main powered parts (**hobs**, ovens, grills, warming plates, griddles etc) used for the measurement shall be recorded. The consumption of low power modes shall be noted for each unit A and B separately.

NOTE The measurement procedure for energy consumption of ovens is described in EN 60350.

When testing appliances that are fitted with a clock, the clock shall be adjusted to the correct time and date as specified in the instructions.

In case energy consumption is influenced by continuous changing displayed time of a clock, a measurement period of 24 h is necessary. The value from this measurement is noted.

If the appliance has an ambient light sensor, two illuminance levels in accordance to EN 50564 shall be measured during the 24 h period, each illuminance level for 12 h.

If an option is provided to the user to switch off the display, both the switched on and switched off mode are to be tested and reported.

Annex B (informative) Addresses of the suppliers

Add the following at the end of Annex B:

B.Z1 Stainless steel for bottom material of cookware (see 7.1.Z2.1)

The plates have a size of 6 mm × 1 000 mm × 2 000 mm.

A possible supplier is:

Tad Inox Service B.V.
Ewald Renz Straße 1
76669 Bad Schönborn / Germany
<http://www.tadinox.de>

B.Z2 Cookware (see 7.1.Z2)

A possible supplier is:

RYBU GmbH
Allmending 27
75203 Königsbach- Stein / Germany
<http://www.rybu.de>

Add the following annexes.

Annex ZA
(normative)

Further requirements for measuring the energy consumption and heating up time for cooking areas

ZA.1 General

For **cooking areas**, the following requirements are additional to 7.1.

ZA.2 Hob with cooking area

ZA.2.1 General

For a **hob** with a **cooking area**, the cookware set is selected depending on the layout.

If a **hob** is a combination from ZA.2.2 and ZA.2.3, than these are evaluated separately.

ZA.2.2 Hob with cooking area without limitative marking

The number of **controls** determines the number of cookware pieces.

The number of **controls** is defined by the number of cookware which can be used independently on the **cooking area** all together at the same time.

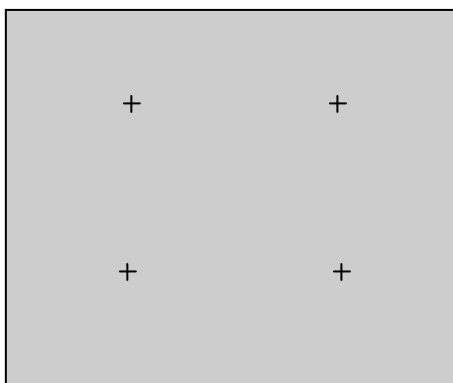

Figure ZA.1 — Exemplary layout for a hob with cooking area without limitative marking

Table ZA.1 – Criteria for cookware set – Cooking areas without limitative marking

Number of controls	Selected cookware set
1 control	Cookware with 210 mm diameter
2 controls	Two cookware pieces with a diameter of 180 mm and 210 mm
3 controls	Three cookware pieces with a diameter of 150 mm, 180 mm and 210 mm
4 controls	Four cookware pieces with a diameter of 150 mm, 180 mm and 210 mm twice
5 controls	Five cookware pieces with a diameter of 150 mm, 180 mm twice and 210 mm twice

NOTE Further specification (lid, height etc.) for cookware pieces are fixed in Table Z3.

If a cookware size is not detected, the next bigger not already covered category according Table Z3 is selected.

If a selected cookware size is out of the range of the sizes allowed by the user manual, then the closest diameter compatible with the defined range has to be chosen.

ZA.2.3 Hob with cooking area with limitative marking

If the **cooking area** has a limitative marking which mark the area where more than one cookware can be used simultaneously, the cookware set is selected as following.

Table ZA.2 – Criteria for cookware set – Cooking areas with limitative marking

Number of controls	Selected cookware set
2 controls	Three cookware pieces with a diameter of 150 mm, 180 mm and 210 mm
3 controls	Three cookware pieces with a diameter of 150 mm, 180 mm and 210 mm

NOTE Further specification (lid, height etc.) for cookware pieces are fixed in Table Z3.

If a cookware size is not detected, the next bigger not already covered category according Table Z3 is selected.

If a selected cookware size is out of the range of the sizes allowed by the user manual, then the closest diameter compatible with the defined range has to be chosen.

The number of **controls** is defined by the number of cookware which can be used independently on the **cooking area** all together at the same time.

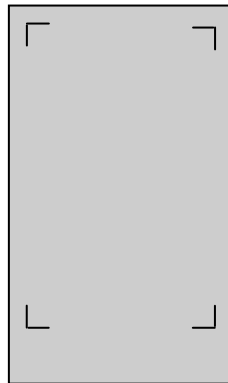

Figure ZA.2 – Exemplary layout for a hob with cooking area with limitative marking

ZA.2.4 Hob with cooking area and cooking zones

Cookware for **cooking zone** and **cooking area** are selected independently.

The cookware set of a combination of **cooking areas** and **cooking zones** in one **hob** is selected for the **cooking zones** according to 7.1.Z3 and for the **cooking area** according to Annex ZA.

ZA.3 Positioning on a cooking area

ZA.3.1 General

All indications of centre positions are considered in the test.

Symbols of **controls** should be considered to define the cookware position.

ZA.3.2 Positioning on a cooking area without limitative markings

The biggest cookware piece has to be placed on a **cooking area** without limitative markings in accordance with the following order of precedence:

- a) having higher **maximum power**;
- b) being located at the rear of the **hob**;
- c) being located at the left.

NOTE Different sizes of indications are not considered.

ZA.3.3 Positioning on a cooking area with limitative markings

The biggest cookware (diameter 210 mm) is positioned in the centre of the **cooking area**. The centre is defined by the geometric centre.

The other cookware pieces (with 180 mm and 150 mm) are positioned in the segmented parts of the **cooking area**. The number of segmented parts is defined by the number of **controls**.

If the centers of the segments are marked then the cookware pieces are positioned on the centre indications. If the segments are marked without centre indications the cookware is positioned in the geometric centre. If the segments are not marked the segments are determined by dividing the long axis of the **cooking area** by the number of **controls**. The cookware pieces are positioned on the geometric centre of these determined segments.

The bigger cookware piece has to be placed in accordance with the following order of precedence:

- a) segmented area having higher **maximum power**;
- b) segmented area being located at the rear of the **hob**;
- c) segmented area being located at the left.

Annex ZB (informative)

Aids for measuring the energy consumption (see 7.1.Z6)

ZB.1 Fixing the temperature measurement instrument to the lid – Example

The temperature measurement instrument according to 5.3 should be fixed in the centre of the lid (see 7.1.Z2) as shown in Figure ZB.1. The mounting part shall be made of plastic material. For the positioning of the right temperature sensor position screws are used.

Dimensions in millimetres

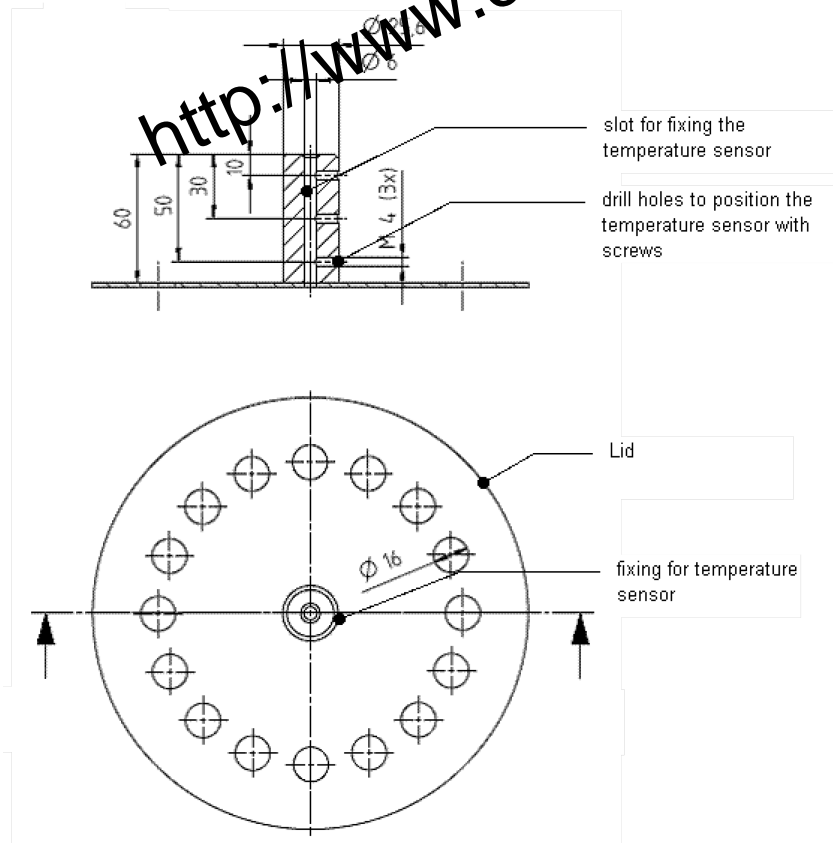

Figure ZB.1 – Position of the temperature measurement instrument

ZB.2 Marking the lowest possible simmering power setting

For marking the lowest possible simmering power setting on the panel, a polar coordinate paper can be useful. Polar coordinate paper has concentric circles divided into small arcs to allow an exact marking around a knob.

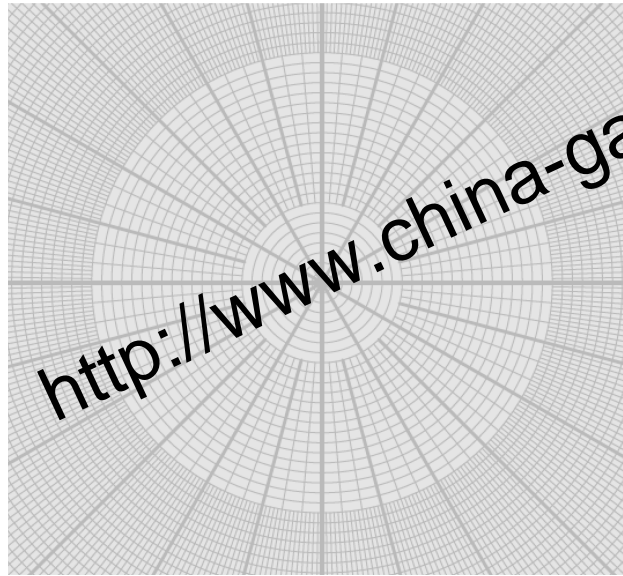

Figure ZB.2 – Polar coordinate paper – Example

Annex ZC
(informative)

Examples how to select and position a cookware set for measuring the heating up time (7.1.Z5) and energy consumption (7.1.Z6)

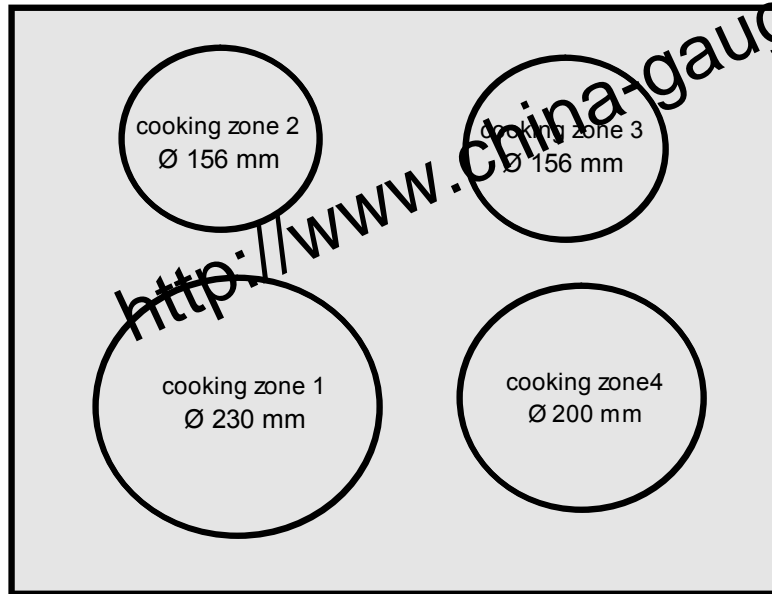

Figure ZC.1 – Example 1: Tubular hotplates, solid hot plates, radiant cooking zone or induction cooking zone

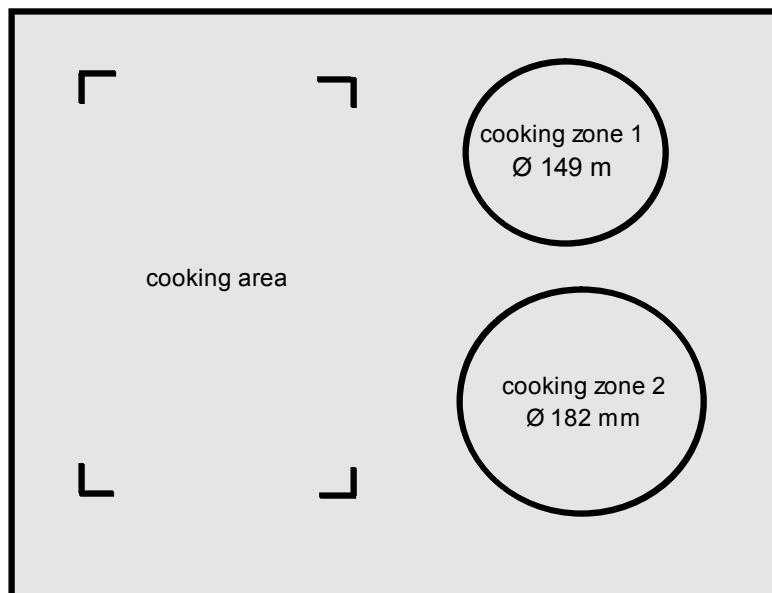

Figure ZC.2 – Example 2: Cooking area combined with two induction or radiant cooking zones

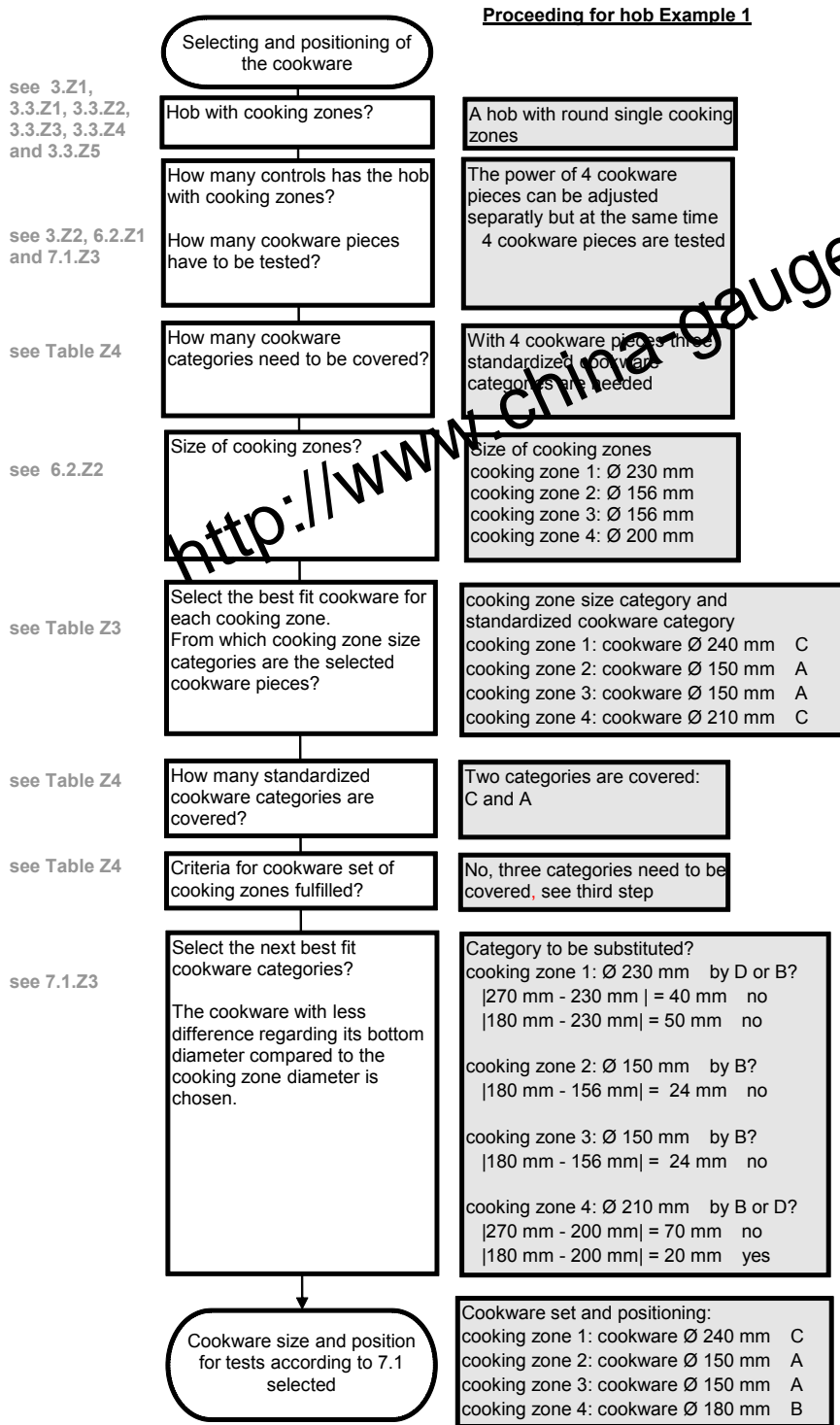

Figure ZC.3 – Proceeding for hob – Example 1

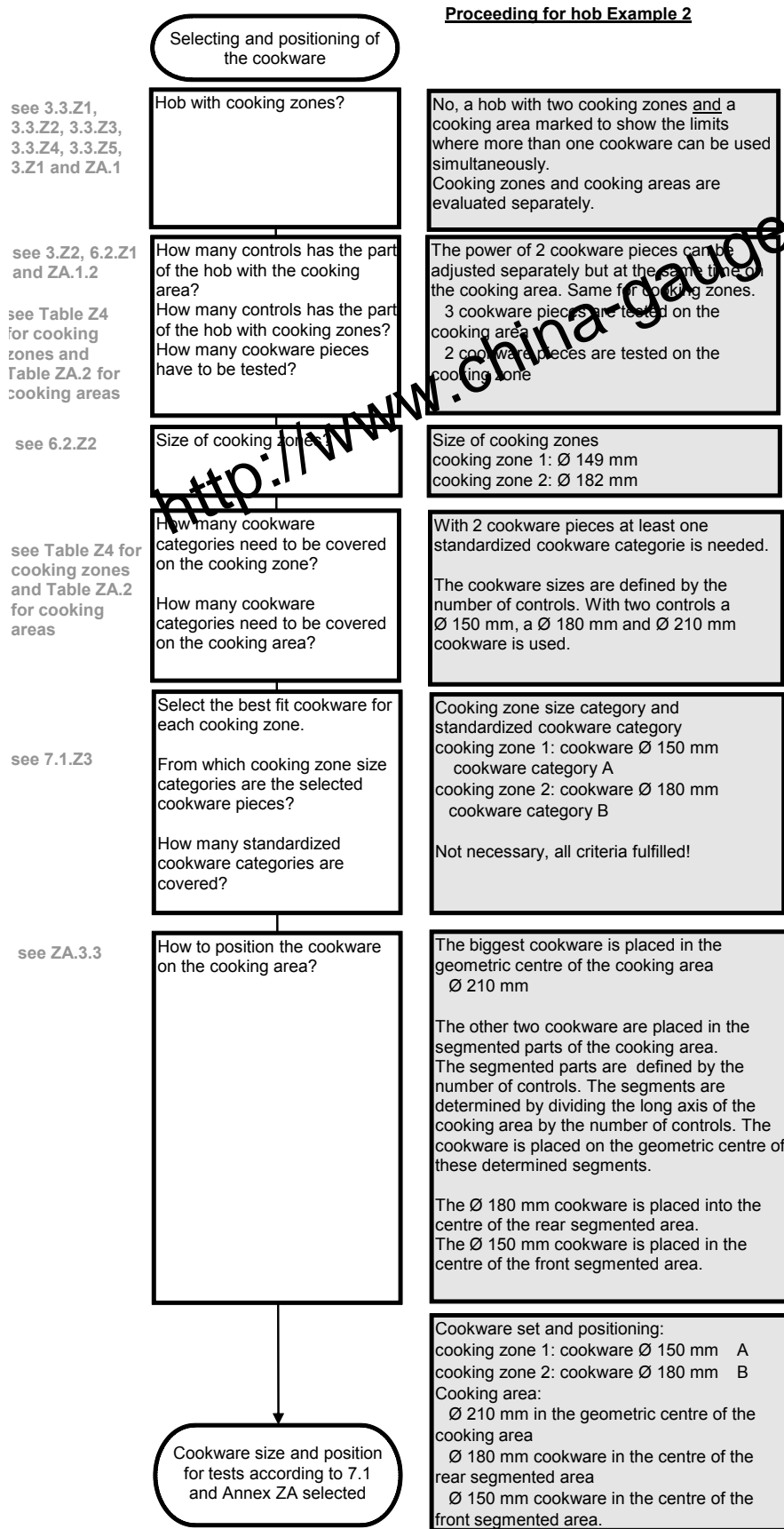

Figure ZC.4 – Proceeding for hob – Example 2

Annex ZD
(informative)

Example – Multiple zones

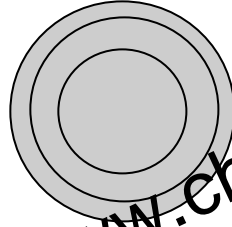

Figure ZD.1 – Circular multiple zones for three different cookware sizes

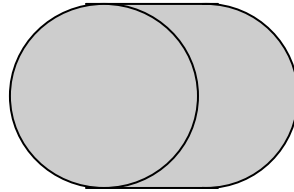

Figure ZD.2 – Combination of circular and elliptical – Multiple zone

<http://www.china-gauges.com/>

Annex ZE
(informative)

Data and calculation sheet: energy consumption of a cooking process (see 7.1.Z6)

Brand & Factory:	Hob Type:	Model:	Testlab:
Rated Voltage: V	Supply Voltage: V	Operator:	
Rated Power: W	Number of Controls (see 6.2.Z1):	Date:	

Cooking zone:	Cooking area:	Cookware Diameter: mm
Type of cooking zone (see 3.3)	without limitave marking: <input type="checkbox"/>	Water load (m_{cw}) g
Cooking Zone Dimension (see 6.2.Z2): mm	with limitative marking: <input type="checkbox"/>	Cookware Position:

7.1.Z6.2.2 Determine Tc								
no.	ambient air pressure (hPa)	ambient temperature (°C)	start water temperature (°C)	time when power level is switched off (hh:mm:ss)	T ₇₀ (°C)	Highest temperature value (°C)	Overshoot T ₀ (K)	Result Tc (°C)
							calc.	calc.

7.1.Z6.3 Measuring energy consumption													
no.	ambient air pressure (hPa)	ambient temperature (°C)	start water temperature (°C)	t _c (hh:mm:ss)	Tc target (°C)	Tc (°C)	continous level	average continous power (W)	t ₉₀ (hh:mm:ss)	energy consumption t90 (Wh)	T _s (°C)	total test time (hh:mm:ss)	E _{cw} total energy consumption (Wh)

Energy consumption of a single cookware under test, normalized to 1000 g water (W_h) **calc.**

Cells with content "calc." should be calculated.

Annex ZF
(normative)

**Normative references to international publications
with their corresponding European publications**

The following documents, in whole or in part, are normatively referenced in this document and are indispensable for its application. For dated references, only the edition cited applies. For undated references, the latest edition of the referenced document (including any amendments) applies.

NOTE When an international publication has been modified by common modifications, indicated by (mod), the relevant EN/HD applies.

<u>Publication</u>	<u>Year</u>	<u>Title</u>	<u>EN/HD</u>	<u>Year</u>
-	-	Stainless steels Part 2: Technical delivery conditions for sheet/plate and strip of corrosion resisting steels for general purposes	EN 10088-2	-
IEC 60364-5-54	-	Low-voltage electrical installations Part 5-54: Selection and erection of electrical equipment - Earthing arrangements and protective conductors	HD 60364-5-54	-
IEC 62301 (mod.)	2011	Electrical and electronic household and office equipment – Measurement of low power consumption	EN 50564	2011
ISO 80000-1 + Cor 1	2009 2011	Quantities and units Part 1: General	EN ISO 80000-1	2013

Bibliography

In the official version, for Bibliography, the following notes have to be added for the standards indicated:

IEC 60335-2-6:2002 +A1:2004 +A2:2008	NOTE Harmonised as EN 60335-2-6:2003 (modified) +A1:2005 (not modified) +A2:2008 (not modified)
IEC 60350-1:2011	NOTE Harmonised as EN 60350-1:2013 (not modified).
IEC 60584-2:1982 +A1:1989	NOTE Harmonised as EN 60584-2:1993 (not modified).
IEC 61591:1997 +A1:2005 +A2:2010	NOTE Harmonised as EN 61591:1997 (not modified) +A1:2006 (not modified) +A2:2011 (not modified)
IEC 61817:2000	NOTE Harmonised as EN 61817:2001 (not modified).
ISO 2813	NOTE Harmonised as EN ISO 2813.

Add the following

EN 60751, *Industrial platinum resistance thermometers and platinum temperature sensors (IEC 60751)*

<http://www.china-gauges.com/>