



BSI Standards Publication

<http://www.china-gauges.com/>

Playground equipment and surfacing

Part 6: Additional specific safety requirements and test methods for rocking equipment

EUROPEAN STANDARD

EN 1176-6

NORME EUROPÉENNE

EUROPÄISCHE NORM

October 2017

ICS 97.200.40

Supersedes EN 1176-6:2008

English Version

Playground equipment and surfacing - Part 6: Additional
specific safety requirements and test methods for
swinging equipment

Equipements et sols d'aires de jeux - Partie
6 : Exigences de sécurité et méthodes
d'essai complémentaires spécifiques
aux équipements oscillants

Spielplatzgeräte und Spielplatzböden - Teil 6:
Zusätzliche besondere sicherheitstechnische
Anforderungen und Prüfverfahren für Wippperäte

This European Standard was approved by CEN on 15 April 2016.

CEN members are bound to comply with the CEN/CENELEC Internal Regulations which stipulate the conditions for giving this European Standard the status of a national standard without any alteration. Up-to-date lists and bibliographical references concerning such national standards may be obtained on application to the CEN-CENELEC Management Centre or to any CEN member.

This European Standard exists in three official versions (English, French, German). A version in any other language made by translation under the responsibility of a CEN member into its own language and notified to the CEN-CENELEC Management Centre has the same status as the official versions.

CEN members are the national standards bodies of Austria, Belgium, Bulgaria, Croatia, Cyprus, Czech Republic, Denmark, Estonia, Finland, Former Yugoslav Republic of Macedonia, France, Germany, Greece, Hungary, Iceland, Ireland, Italy, Latvia, Lithuania, Luxembourg, Malta, Netherlands, Norway, Poland, Portugal, Romania, Serbia, Slovakia, Slovenia, Spain, Sweden, Switzerland, Turkey and United Kingdom.



EUROPEAN COMMITTEE FOR STANDARDIZATION
COMITÉ EUROPÉEN DE NORMALISATION
EUROPÄISCHES KOMITEE FÜR NORMUNG

CEN-CENELEC Management Centre: Avenue Marnix 17, B-1000 Brussels

European foreword

This document (EN 1176-6:2017) has been prepared by Technical Committee CEN/TC 136 "Sports, playground and other recreational facilities and equipment", the secretariat of which is held by DIN.

This European Standard shall be given the status of a national standard, either by publication of an identical text or by endorsement, at the latest by April 2018, and conflicting national standards shall be withdrawn at the latest by October 2018.

Attention is drawn to the possibility that some of the elements of this document may be the subject of patent rights. CEN shall not be held responsible for identifying any or all such patent rights.

This document supersedes EN 1176-6:2008.

This European Standard EN 1176 "Playground equipment and surfacing" consists of a number of parts as follows:

- *Part 1: General safety requirements and test methods*
- *Part 2: Additional specific safety requirements and test methods for swings*
- *Part 3: Additional specific safety requirements and test methods for slides*
- *Part 4: Additional specific safety requirements and test methods for cableways*
- *Part 5: Additional specific safety requirements and test methods for carousels*
- *Part 6: Additional specific safety requirements and test methods for rocking equipment*
- *Part 7: Guidance on installation, inspection, maintenance and operation*
- *Part 10: Additional specific safety requirements and test methods for fully enclosed play equipment*
- *Part 11: Additional specific safety requirements and test methods for spatial network*

This part of EN 1176 is to be used in conjunction with EN 1176-1, EN 1176-7 and EN 1177.

For inflatable play equipment see EN 14960, *Inflatable play equipment — Safety requirements and test methods*.

The principal changes from the previous edition of this part of EN 1176 are as follows:

- a) type 2, 3 and 4 is not classified as a forced movement equipment;
- b) rocking equipment provided for standing use the falling space shall be at least 1,5 m.

According to the CEN/CENELEC Internal Regulations, the national standards organizations of the following countries are bound to implement this European Standard: Austria, Belgium, Bulgaria, Croatia, Cyprus, Czech Republic, Denmark, Estonia, Finland, Former Yugoslav Republic of Macedonia, France, Germany, Greece, Hungary, Iceland, Ireland, Italy, Latvia, Lithuania, Luxembourg, Malta, Netherlands, Norway, Poland, Portugal, Romania, Serbia, Slovakia, Slovenia, Spain, Sweden, Switzerland, Turkey and the United Kingdom.

Contents

	Page
European foreword	2
European foreword	4
1 Scope	5
2 Normative references	5
3 Terms and definitions	5
4 Safety requirements	10
4.1 General	10
4.2 Free height of fall	10
4.3 Seat/stand slope	10
4.4 Pinch, crush	10
4.5 Restraint of motion	10
4.6 Foot rests	11
4.7 Hand supports	11
4.8 Side view profiles	11
4.9 Entrapment	11
4.10 Falling space	12
4.11 Anchor covering	12
5 Additional type requirements	13
5.1 Axial seesaw (Type 1)	13
5.2 Multi point seesaw/rocking equipment (Type 3A)	13
5.3 Rocking seesaw (Type 4)	14
5.4 Overhead single axis seesaw (Type 6)	14
5.5 Forced movement	15
6 Test reports	15
7 Marking	15
Annex A (informative) Guidance for assessing the safety of rocking equipment other than Types 1 to 6	16
Annex B (normative) Determination of seat/stand slope and ground clearance	17
Annex C (normative) Determination of freedom from pinch and crush points	18
Annex D (normative) Determination of sideways stability	19
Annex E (normative) Determination of hand support and/or foot rest projection	20

European foreword

This document (EN 1176-6:2017) has been prepared by Technical Committee CEN/TC 136 "Sports, playground and other recreational facilities and equipment", the secretariat of which is held by DIN.

This European Standard shall be given the status of a national standard, either by publication of an identical text or by endorsement, at the latest by April 2018, and conflicting national standards shall be withdrawn at the latest by October 2018.

Attention is drawn to the possibility that some of the elements of this document may be the subject of patent rights. CEN shall not be held responsible for identifying any or all such patent rights.

This document supersedes EN 1176-6:2008.

This European Standard EN 1176 "Playground equipment and surfacing" consists of a number of parts as follows:

- *Part 1: General safety requirements and test methods*
- *Part 2: Additional specific safety requirements and test methods for swings*
- *Part 3: Additional specific safety requirements and test methods for slides*
- *Part 4: Additional specific safety requirements and test methods for cableways*
- *Part 5: Additional specific safety requirements and test methods for carousels*
- *Part 6: Additional specific safety requirements and test methods for rocking equipment*
- *Part 7: Guidance on installation, inspection, maintenance and operation*
- *Part 10: Additional specific safety requirements and test methods for fully enclosed play equipment*
- *Part 11: Additional specific safety requirements and test methods for spatial network*

This part of EN 1176 is to be used in conjunction with EN 1176-1, EN 1176-7 and EN 1177.

For inflatable play equipment see EN 14960, *Inflatable play equipment — Safety requirements and test methods*.

The principal changes from the previous edition of this part of EN 1176 are as follows:

- a) type 2, 3 and 4 is not classified as a forced movement equipment;
- b) rocking equipment provided for standing use the falling space shall be at least 1,5 m.

According to the CEN/CENELEC Internal Regulations, the national standards organizations of the following countries are bound to implement this European Standard: Austria, Belgium, Bulgaria, Croatia, Cyprus, Czech Republic, Denmark, Estonia, Finland, Former Yugoslav Republic of Macedonia, France, Germany, Greece, Hungary, Iceland, Ireland, Italy, Latvia, Lithuania, Luxembourg, Malta, Netherlands, Norway, Poland, Portugal, Romania, Serbia, Slovakia, Slovenia, Spain, Sweden, Switzerland, Turkey and the United Kingdom.

1 Scope

This document is applicable to rocking equipment which is used as playground equipment for children, as defined in 3.1. Where the main play function is not rocking, the relevant requirements in this document may be used, as appropriate.

This document specifies additional safety requirements and test methods for seesaws and rocking equipment intended for permanent installation for use by children.

It is intended to provide protection to the user against possible hazards during use.

NOTE Guidance for assessing the safety of other forms of seesaw/rocking equipment is given in informative Annex A.

2 Normative references

The following documents, in whole or in part, are normatively referenced in this document and are indispensable for its application. For dated references, only the edition cited applies. For undated references, the latest edition of the referenced document (including any amendments) applies.

EN 1176-1:2017, *Playground equipment and surfacing — Part 1: General safety requirements and test methods*

3 Terms and definitions

For the purposes of this document, the terms and definitions given in EN 1176-1 and the following apply.

3.1

rocking equipment

seesaw (hereinafter referred to as equipment)

equipment that can be set in motion by the user and is generally characterized by a rigid element that rocks about a central support

Note 1 to entry: The equipment can have one or several seats or stands.

Note 2 to entry: [Figure 1a](#)) shows the principle components for rocking equipment. [Figure 1b](#)) shows the principle components for seesaws.

Note 3 to entry: The seesaw/rocking movement depends on the type and configuration of fixture (see [Figures 2 to 7](#)).

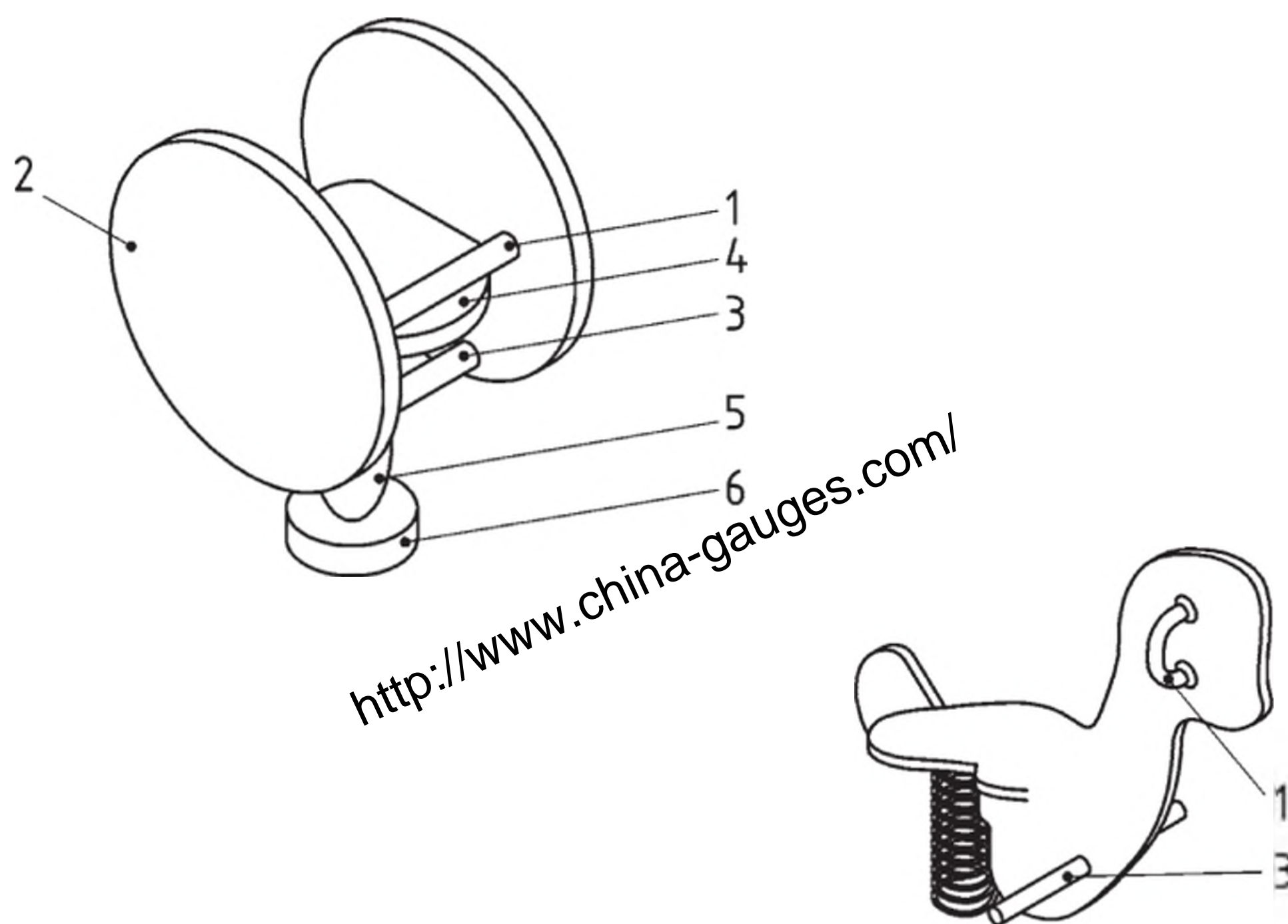

a) Rocking equipment

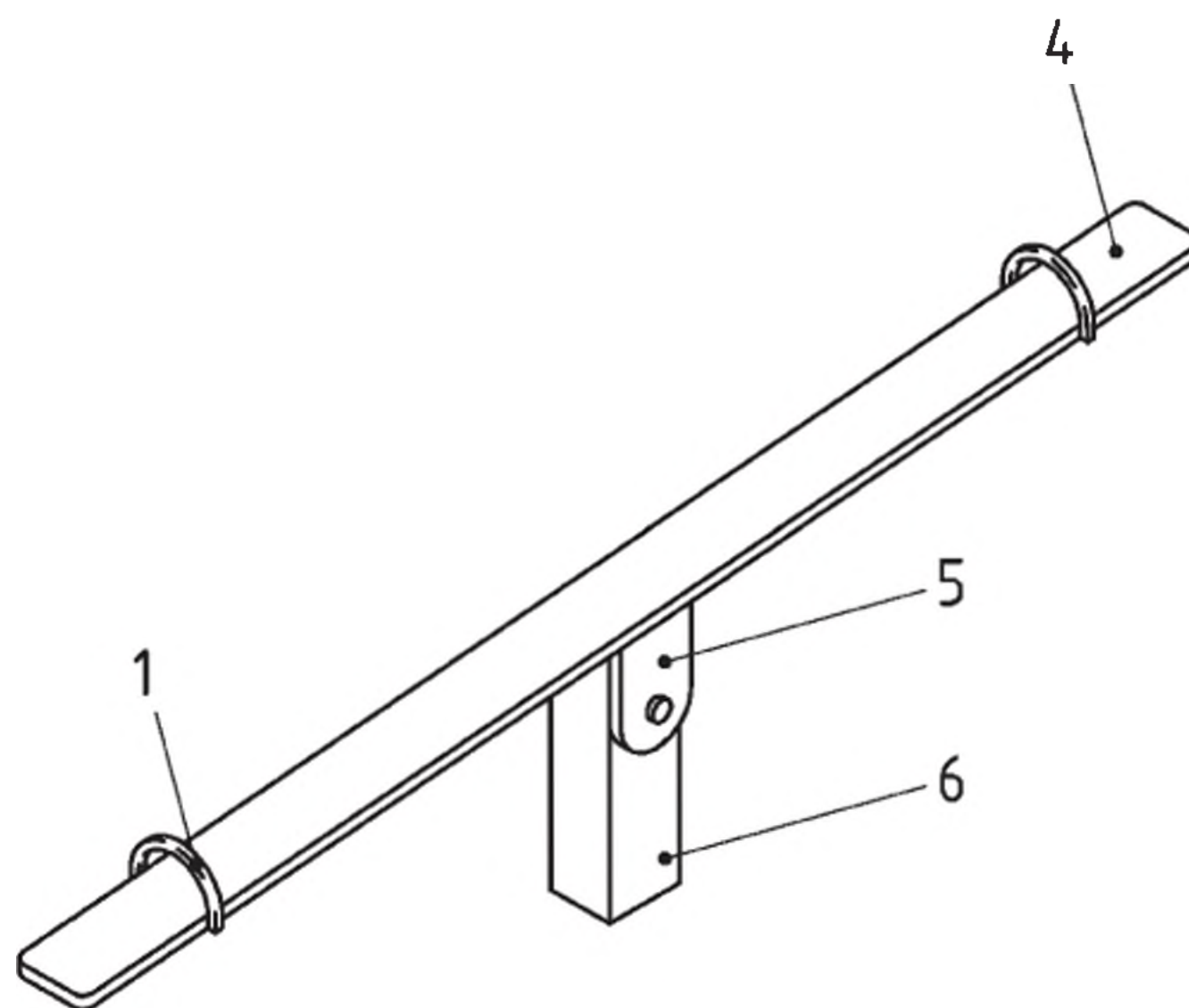

b) Seesaw

Key

1 hand support

2 body

3 foot rest

4 seat/stand

5 supporting component

6 anchorage

Figure 1 — Principal components for rocking equipment/seesaw

3.2

axial seesaw (Type 1)

equipment in which only vertical movement can take place

NOTE See [Figure 2](#).

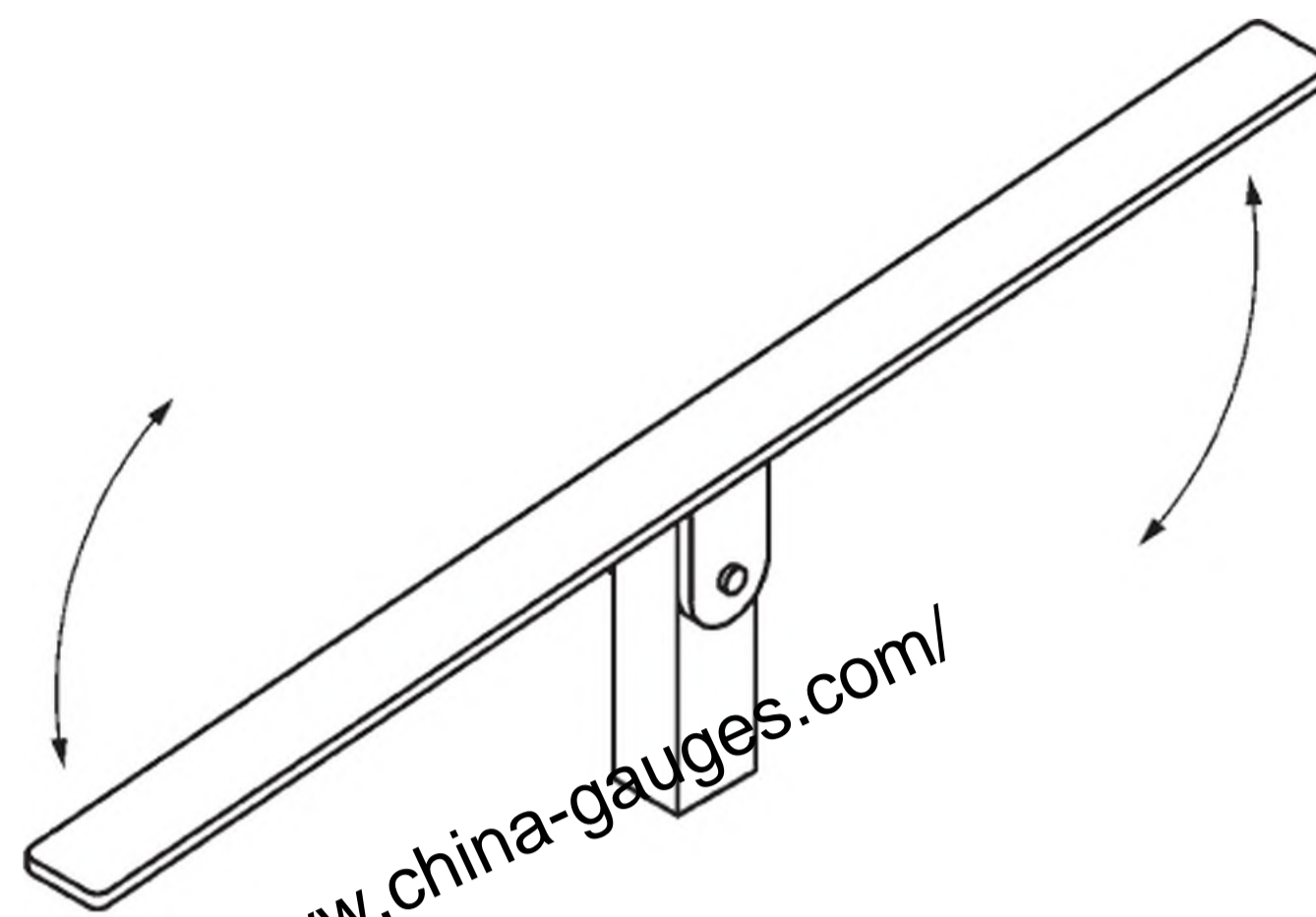
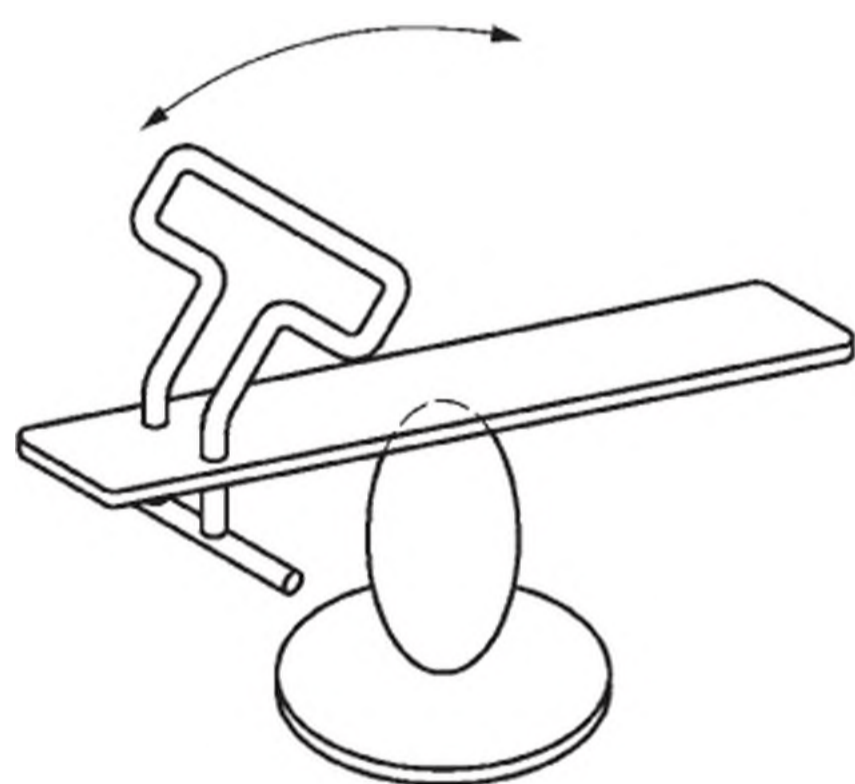

Figure 2 — Example of an axial seesaw (Type 1)

3.3
single point seesaw
single point rocking equipment (Type 2A and 2B)
equipment with a single point supporting component

Note 1 to entry: See [Figure 3](#).

Note 2 to entry: Typical single point supporting components include: coils, springs, torsion and compression blocks.



a) Type 2A with predetermined main direction of movement

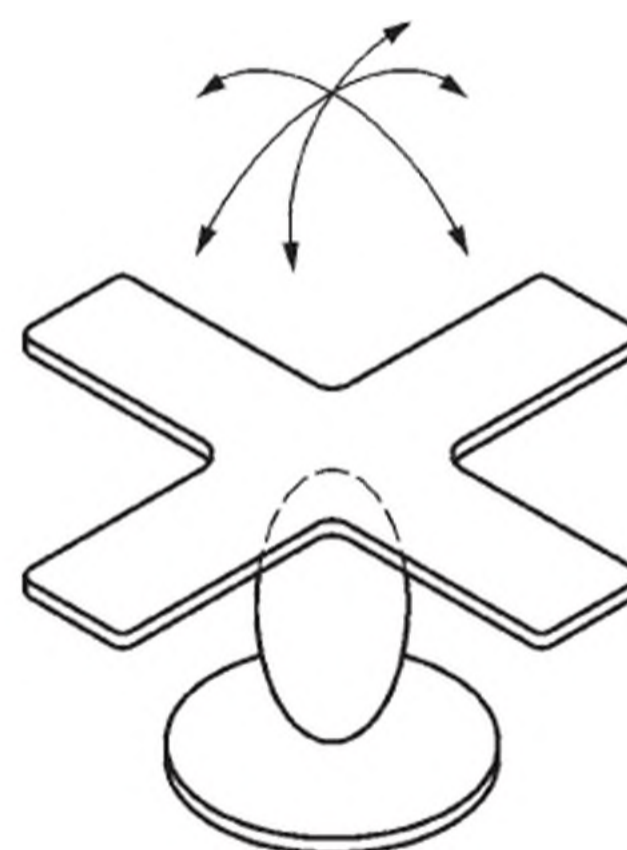

b) Type 2B with multi-directional movement

Figure 3 — Examples of single point seesaw/rocking equipment (Types 2A and 2B)

3.4
multi point seesaw
multi point rocking equipment (Types 3A and 3B)
equipment with several supporting components

Note 1 to entry: See [Figure 4](#).

Note 2 to entry: The movement depends upon the placement and type of supporting components.

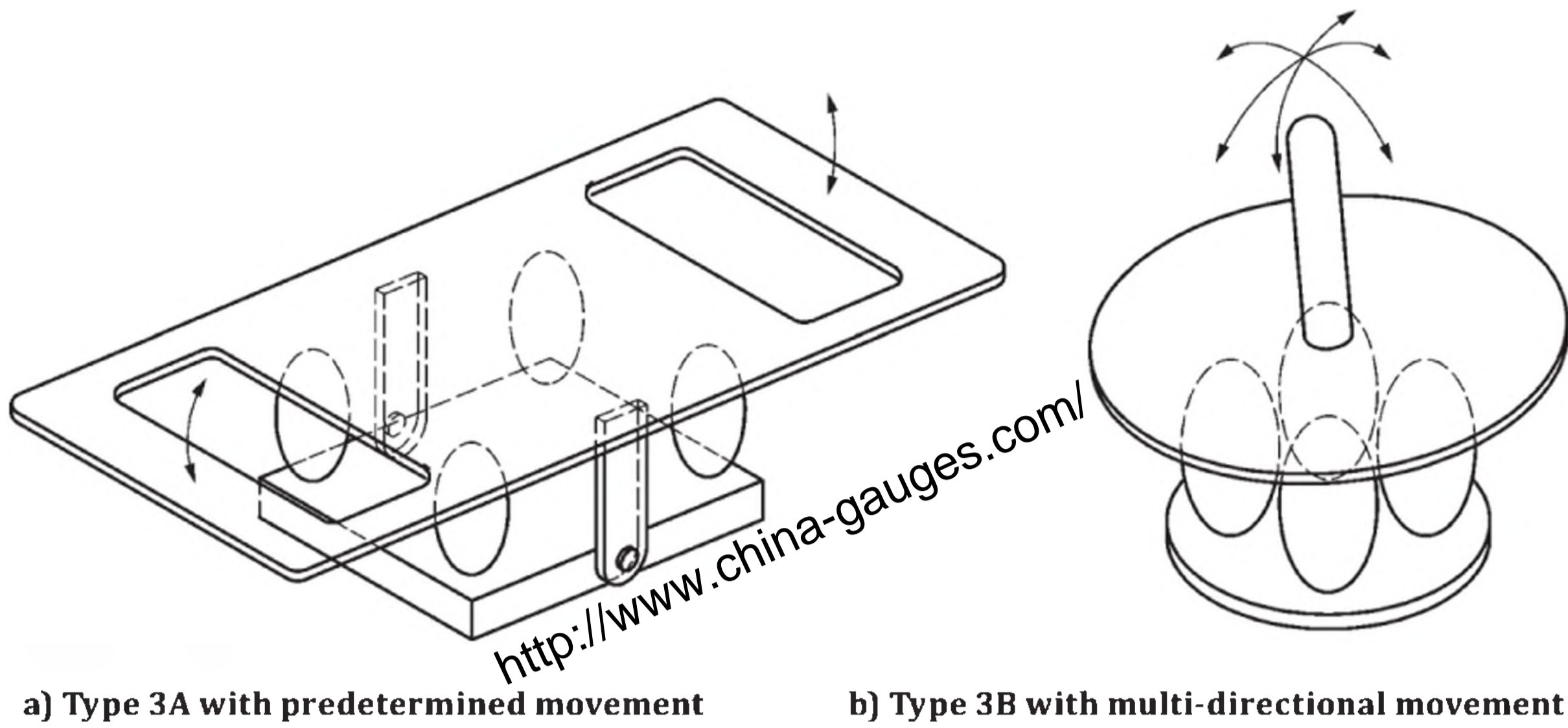

Figure 4 — Examples of multi point seesaw (Types 3A and 3B)

3.5
rocking seesaw (Type 4)

equipment that is fixed so that the movement, which is mainly horizontal, is guided by several parallel axes and moves in one (to fro) direction only

NOTE See [Figure 5](#).

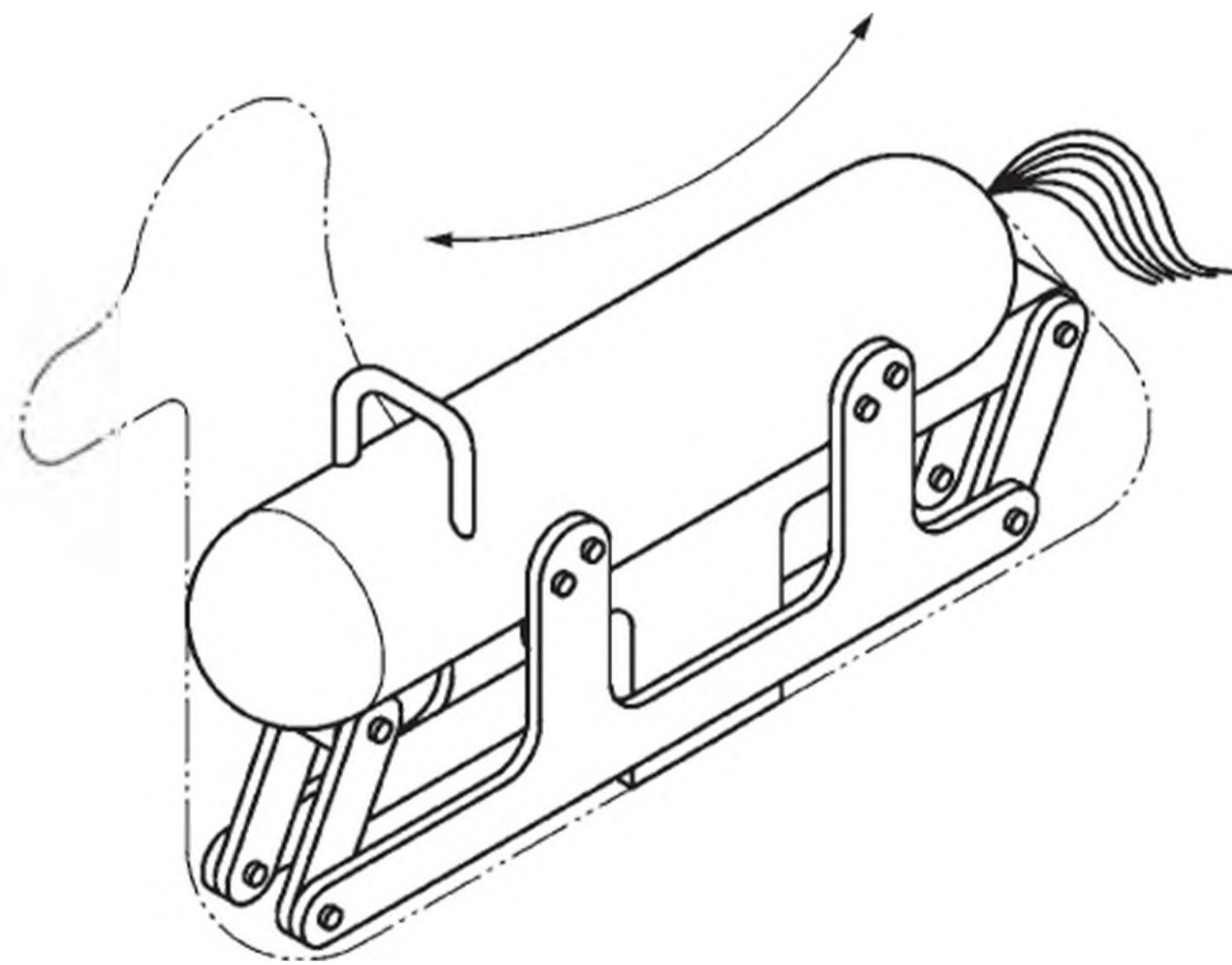
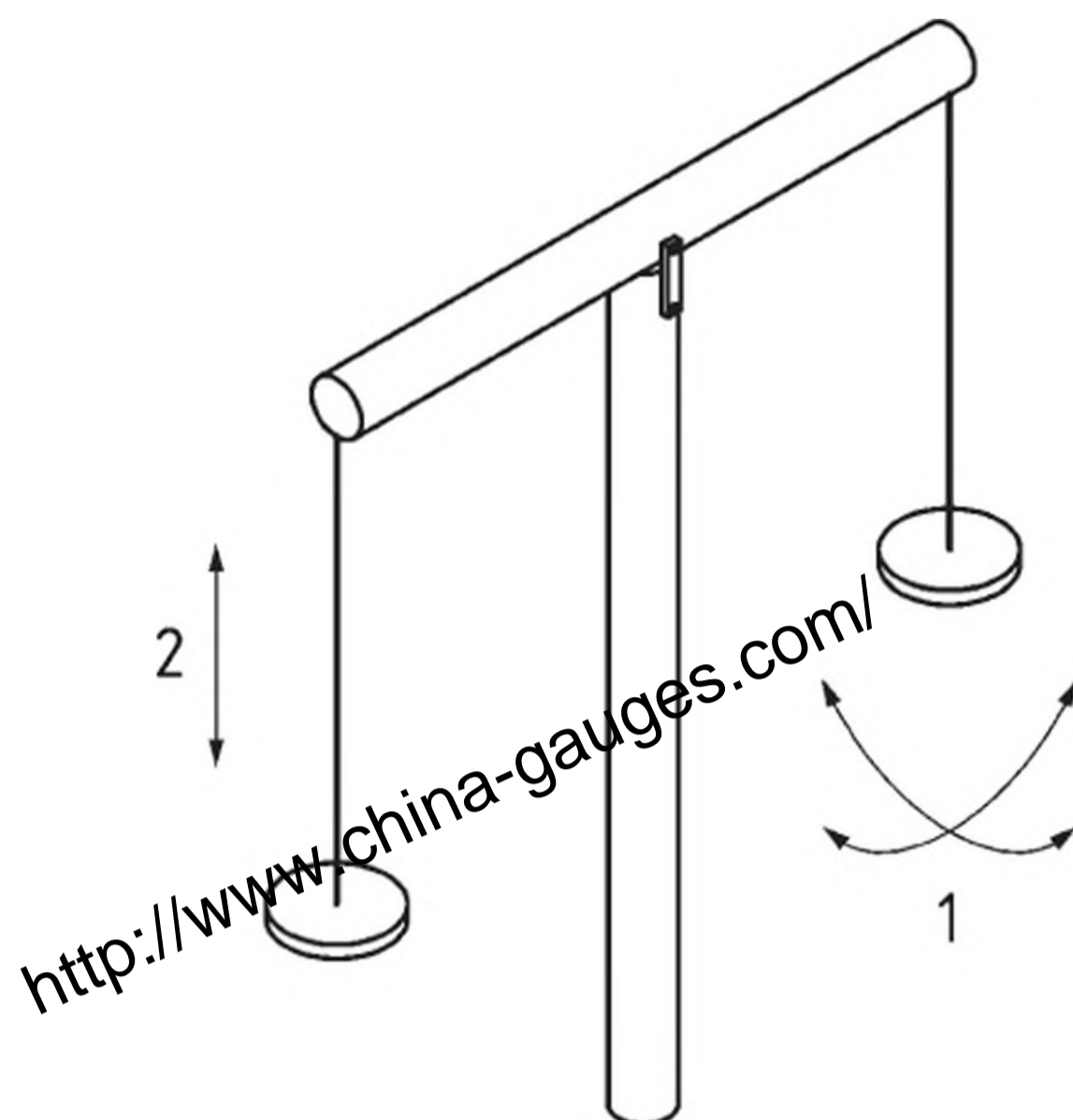

Figure 5 — Example of a rocking seesaw (Type 4)

3.6
sweeping seesaw supported above the users position (Type 5)

equipment in which both vertical and horizontal movement takes place (multi directional), which may result in a sweeping motion

NOTE See [Figure 6](#).



Key

- 1 circular movement around central post
- 2 rocking movement

Figure 6 — Example of a sweeping seesaw supported above the users position (Type 5)

3.7

overhead single axis seesaw (Type 6)

equipment with a single overhead rocking axis, where the user stations are flexibly suspended below to provide an additional limited swinging motion

NOTE See [Figure 7](#).

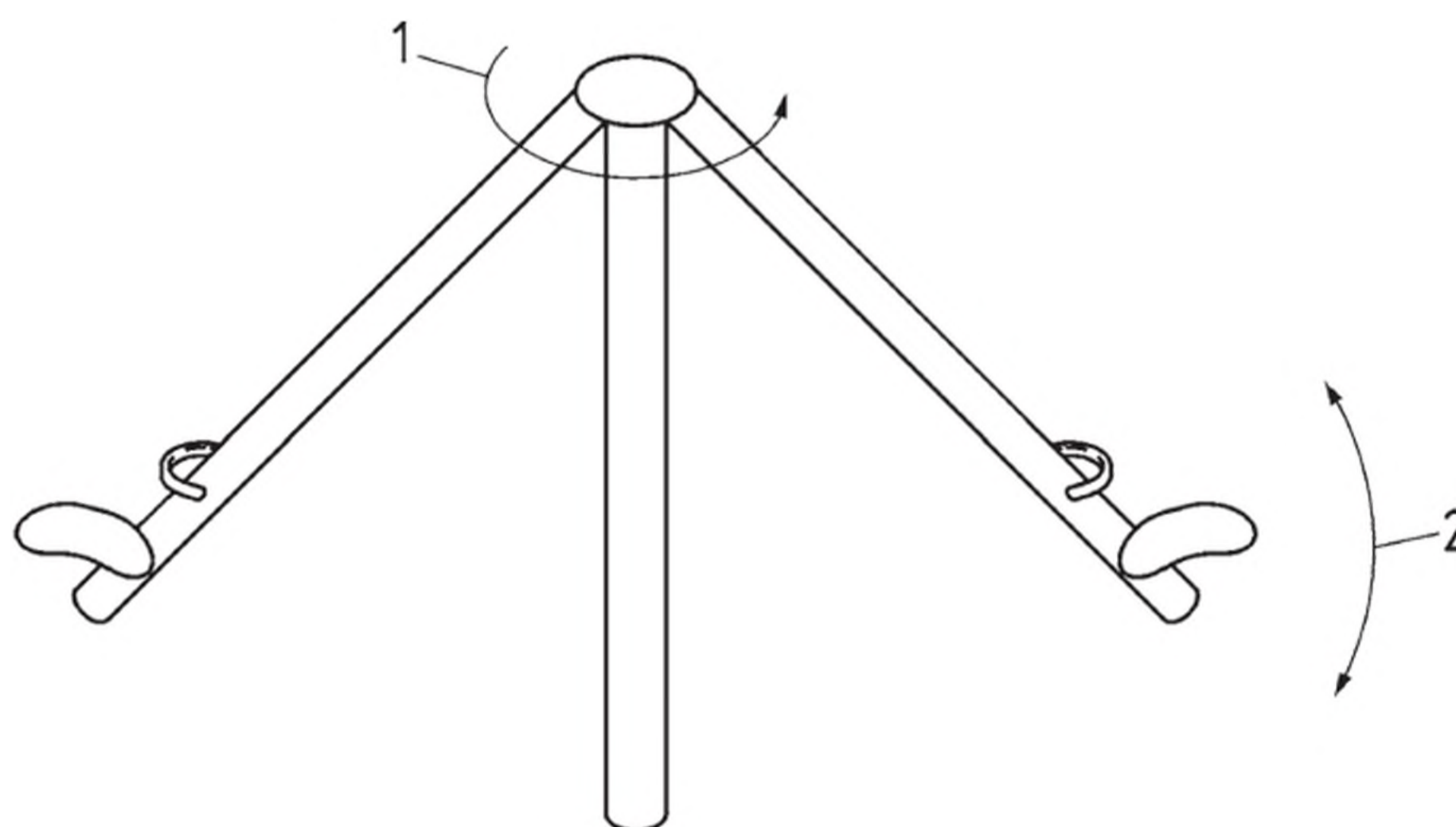

Key

- 1 limited swinging movement
- 2 rocking movement

Figure 7 — Example of overhead single axis seesaw (Type 6)

3.8

equipment body

main moving part connected to the equipment supporting component(s)

3.9

supporting component

component which connects the equipment body to the anchorage

3.10

Anchorage

means by which stability and fixation to the ground/surface is made

3.11

damping

combined effect of the supporting component(s) that moderates the speed at which the equipment can move and the reduction of shock effects at the outer positions of the equipment

3.12

range of movement

maximum horizontal and/or vertical deviation of the seat/stand during use from the centre point at equilibrium position

4 Safety requirements

4.1 General

Unless otherwise specified, seesaw/rocking equipment shall conform to EN 1176-1 .

4.2 Free height of fall

When measured at extreme positions of movement, the centre of the seat/stand shall have a maximum free height of fall in accordance with [Table 1](#).

4.3 Seat/stand slope

When tested in accordance with normative [Annex B](#), the maximum slope at the seat/stand shall be in accordance with [Table 1](#).

4.4 Pinch, crush

When tested in accordance with normative [Annex C](#), gaps in all accessible joints and supporting components shall conform to EN 1176-1:2017, 4.2.6 and 4.2.7.

NOTE This requirement is intended to prevent pinching and crushing.

4.5 Restraint of motion

The motion of equipment should be regulated towards the extremities of movement so that no sudden stop or sudden reversal of the motion can occur, e.g. damping.

NOTE 1 The damping effect can be:

- a) constant, where the effect is constant throughout the entire range of movement; or
- b) varied, where the effect depends on the speed, mass and/or position of the rocking parts of the equipment.

NOTE 2 This is to reduce the risk of spinal injuries due to sudden shock load, e.g. by use of a spring or other damping elements.

4.6 Foot rests

Where foot rests are provided they shall be firmly fixed and unable to rotate without using tools.

When tested in accordance with normative [Annex E](#), no part of the foot rest shall project beyond the outer face of the gauge.

4.7 Hand supports

They shall be firmly fixed and unable to rotate without using tools.

For equipment accessible for use by younger children the grip requirements should be selected from the lower end of the range; maximum diameter/cross-section of 30 mm is recommended.

When tested in accordance with normative [Annex E](#), no part of the hand support shall project beyond the outer face of the gauge.

NOTE The intention of this requirement is to reduce the hazard of eye injury from the ends of projecting hand supports, by maintaining a cross sectional area of at least 15 cm².

4.8 Side view profiles

Those parts of the side profile, which can give an impact on children passing by or on the user shall not have projections with a radius of less than 20 mm (see [Figure 8](#)).

Changes in the shape of the edge of the front and the back of parts, projecting from the principal profile, shall be rounded with a radius of at least 20 mm (see [Figure 8](#)).

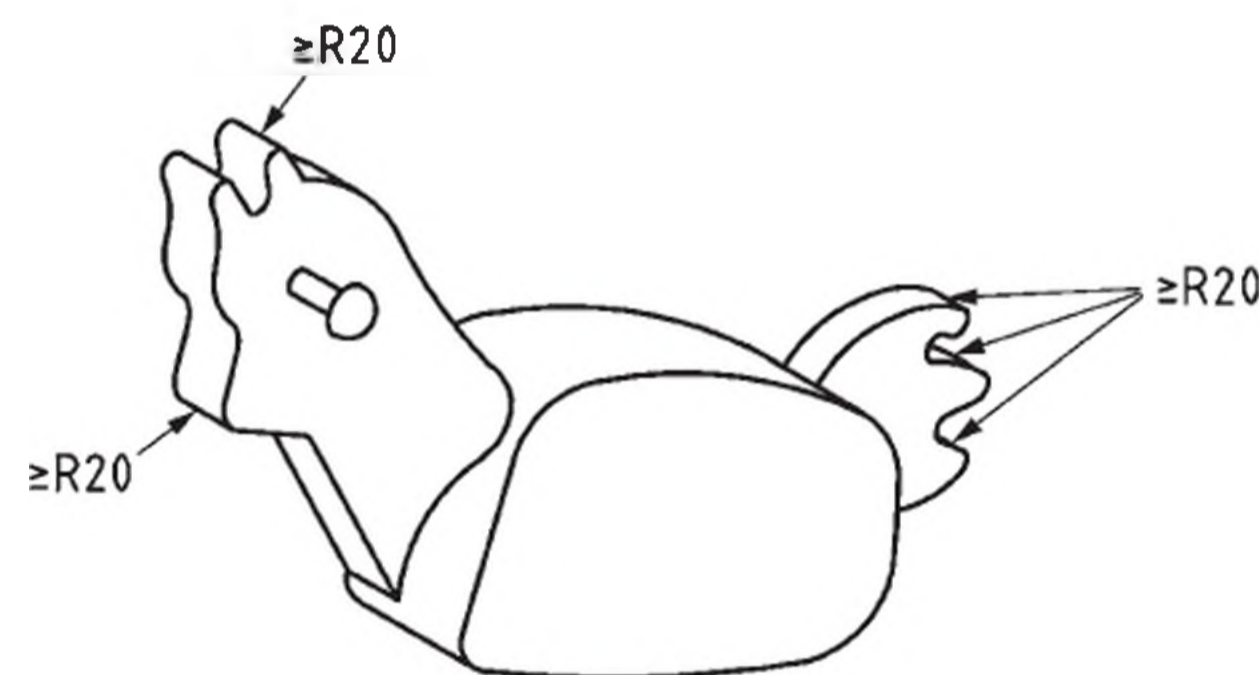

Figure 8 — Example for rounded side profile

4.9 Entrapment

Equipment shall be designed to prevent entrapment between the equipment and ground surface (see [Table 1](#)). This may be achieved by

- having a minimum ground clearance of 230 mm; or
- use of damping effects; or
- deflecting effects from the construction of the equipment.

When tested in accordance with normative [Annex C](#), the supporting component shall not compress by more than 5 % and it shall be possible to insert the 12 mm diameter rod at all extreme positions.

4.10 Falling space

For equipment Types 1, 2, 3 and 4, when measured from the perimeter of the equipment in its most extreme positions, the falling space shall be a minimum of 1 000 mm (see Figure 9). When equipment is intended to be used in standing position, the falling space shall be a minimum of 1 500 mm.

Rocking equipment types 2, 3 and 4 the impact area shall have a critical fall height of at least 600 mm.

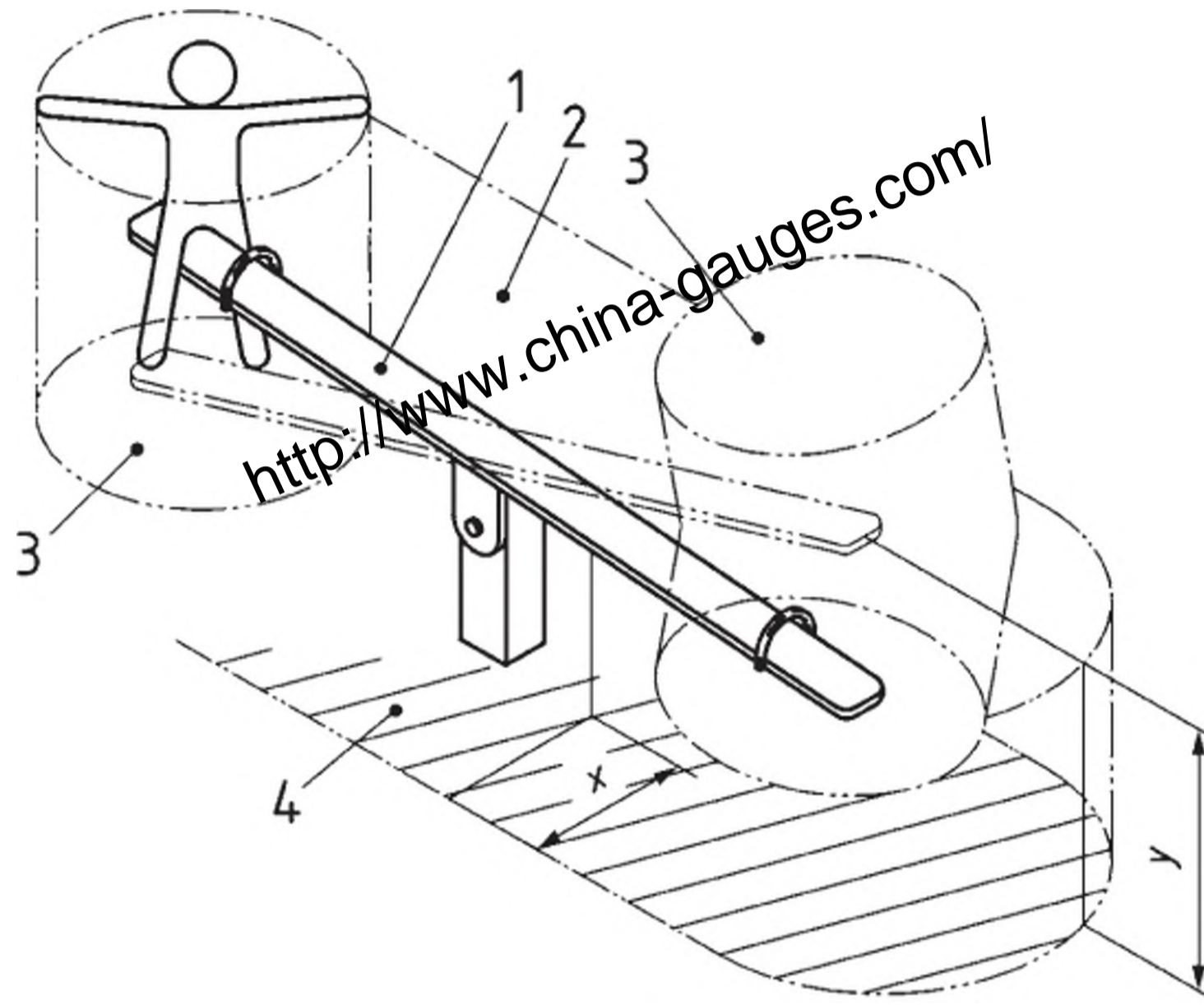

Key

- 1 space occupied by the equipment
- 2 falling space
- 3 free space
- 4 impact area
- x extent of falling space

Figure 9 — Examples of falling space of rocking equipment Type 1

For equipment Types 5 and 6, the requirements for the impact and falling space shall be in accordance with EN 1176-1:2017, 4.2.8.2.4 and 4.2.8.2.5.

4.11 Anchor covering

For single user rocking equipment, with a free height of fall, less than 600 mm, any exposed anchoring shall be less than 1,3 times the width of the seat. See Figure 10.

Dimensions in millimetres

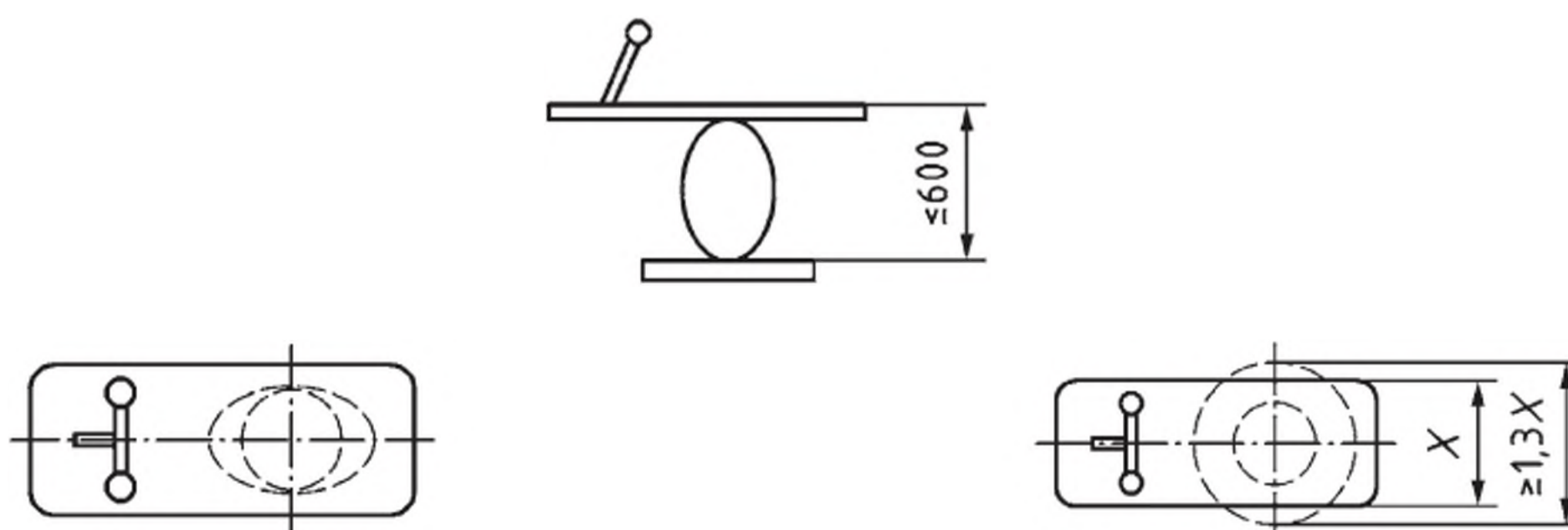

Pass

Fail

Figure 10 — Anchor covering

Table 1 — Safety requirements

Type	Maximum free height of fall (see 4.2) mm	Maximum slope of seats/stand (see 4.3)	Ground clearance ^a mm
1	1 500	20	230 min.
2A	1 000	30	optional
2B	1 000	30	230 min.
3A	1 000	30	optional
3B	1 000	30	230 min.
4	1 000	20	230 min.
5	2 000	—	230 min.
6	2 000	—	230 min.

^a With the exception of type 4 (see 5.3), minimum ground clearance is not required when: 1) There is a damping effect, e.g. the supporting component is a spring. 2) The motion of the extremity of the structure is mainly in a horizontal direction (deflecting effect).

5 Additional type requirements

5.1 Axial seesaw (Type 1)

When measured at a distance of 2 000 mm from the axis point, and tested in accordance with normative [Annex D](#), the lateral deviation shall not be greater than 140 mm (see [Figure 11](#)).

Suitable damping shall be provided.

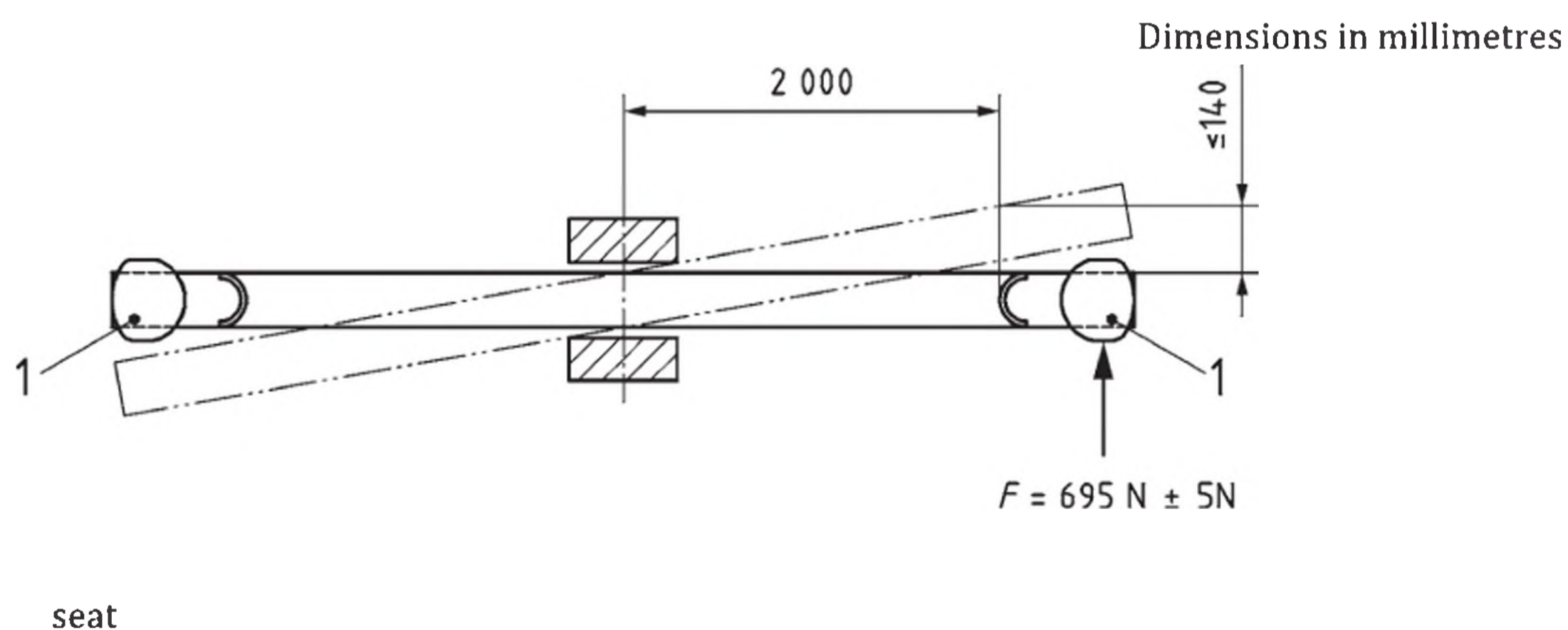
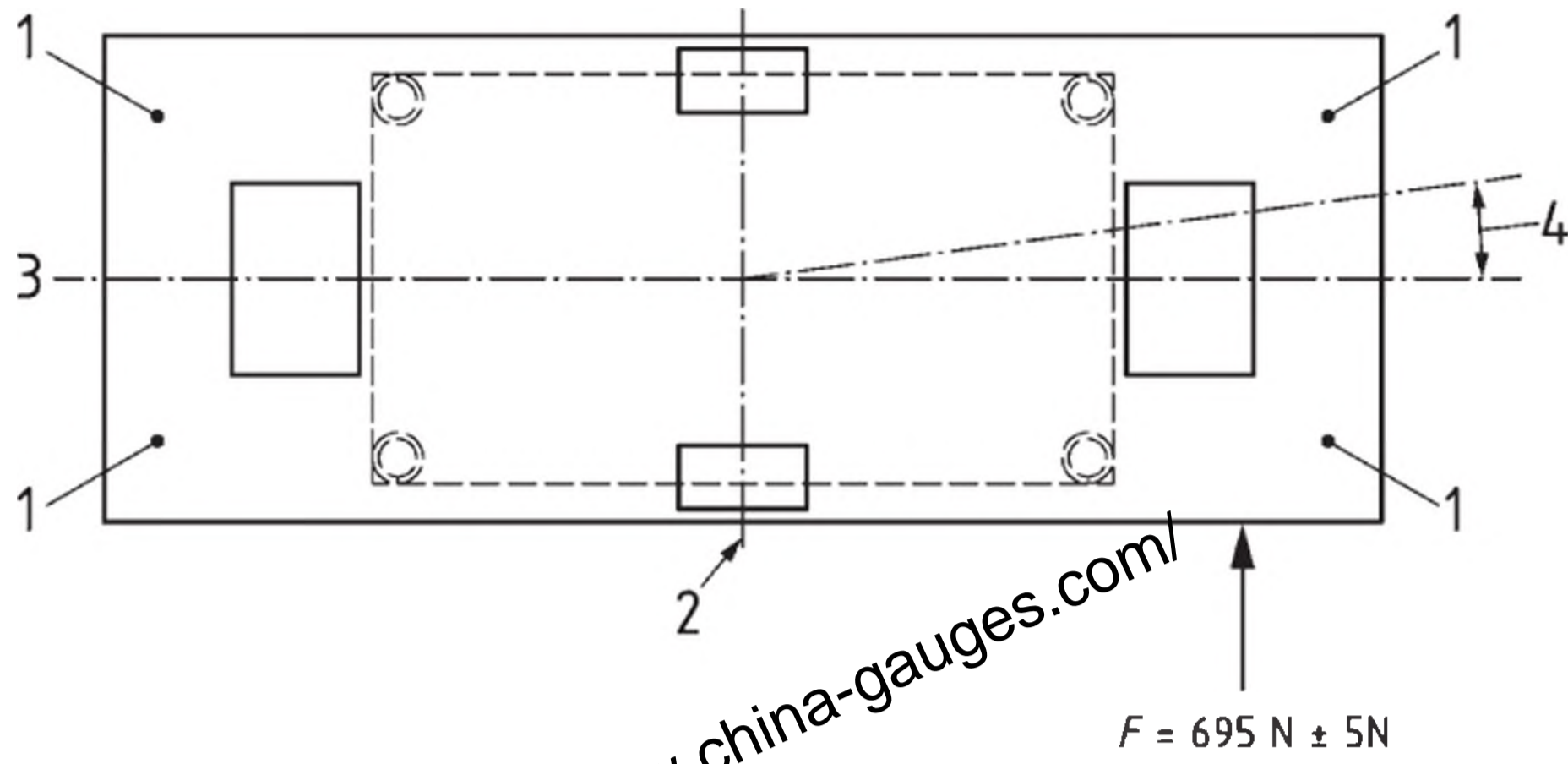

Figure 11 — Type 1 seesaw lateral deviation

5.2 Multi point seesaw/rocking equipment (Type 3A)

For Type 3A equipment, changes in the angle during rotation around the vertical axis shall not exceed 5° when loaded with the intended number of users and tested in accordance with normative [Annex D](#) (see [Figure 12](#)).



Key

- 1 seat position
- 2 horizontal axis of seesaw
- 3 longitudinal axis of seesaw
- 4 deviation of longitudinal axis when application of F

Figure 12 — Type 3A multipoint equipment deviation (aerial view)

5.3 Rocking seesaw (Type 4)

The total range of the movement shall not exceed 600 mm.

Ground clearance shall in all position be at least 230 mm.

5.4 Overhead single axis seesaw (Type 6)

The free height of fall of an overhead single axis seesaw shall not exceed 2 000 mm, when measured as shown in [Figure 13](#).

The free space for a type 6 seesaw shall be as specified in EN 1176-1:2017, 4.2.8.2.3, for a seated user.

Dimensions in millimetre

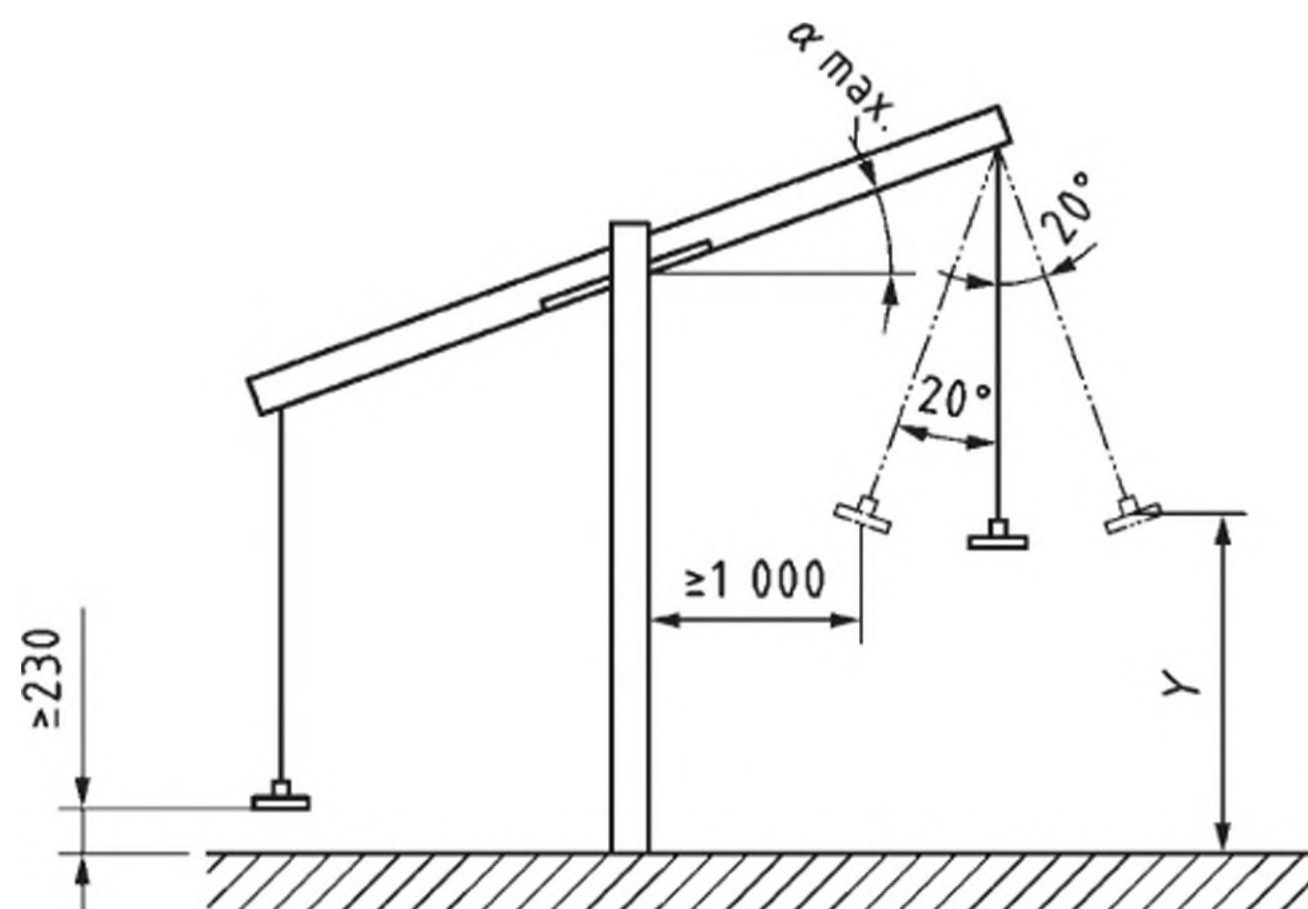

Key

- α maximum inclination of the beam during use of the equipment
- Y free height of fall

Figure 13 — Free height of fall of overhead single axis seesaw (Type 6)

As the main motion of the user is rocking, the angle of the swinging part of the motion should be not more than 20°.

5.5 Forced movement

Equipment types 2, 3 and 4 are exempt from forced movement requirements.

6 Test reports

Test reports shall be in accordance with EN 1176-1:2017, Clause 5, in addition to the following:

- a) test report regarding conformity of the equipment to EN 1176-6;
- b) certification of conformity with the relevant requirements of EN 1176-1 and EN 1176-6;
- c) the number and date of this European Standard, i.e. EN 1176-6:2017.

7 Marking

Seesaw/rocking equipment shall be marked in accordance with EN 1176-1:2017, Clause 7.

Marking shall be positioned on the seesaw/rocking equipment in a location that will be visible when erected on site.

Annex A (informative)

Guidance for assessing the safety of rocking equipment other than Types 1 to 6

Some equipment is supplied with supporting components designed to provide motion. Such equipment is characterized by different sizes and configurations and additional safety requirements not addressed in this part of the EN 1176 series might need to be considered.

If there are borderline contradictions in the requirements and test methods presented in this part of EN 1176 series, play value should be favoured after consideration of the professional judgement of approved, reputable test houses based within the EU.

Annex B (normative)

Determination of seat/stand slope and ground clearance

B.1 Principle

A load is applied to the equipment in the worst case position on the seat/stand, the angle of tilt is measured and the equipment is examined to see if extreme parts of the equipment touch the ground.

B.2 Apparatus

B.2.1 Device, capable of applying a force in accordance with EN 1176-1:2017, Table A.1.

B.2.2 Device for Type 2B, capable of applying a force of $(167 \pm 2,1)$ N for age group up to 4 years and/or a force of (279 ± 5) N for age group up to 8 years.

B.3 Procedure

B.3.1 Load the seat/stand in its equilibrium position, in each user position, with the test load specified in EN 1176-1:2017, Table A.1. Incline the loaded seat/stand to the maximum specified seat/stand angle, as given in [Table 1](#), and release the seat/stand. If the seat/stand does not continue moving towards the ground or if the loaded seat/stand moves back towards its equilibrium position, the equipment conforms to the requirement for maximum seat/stand angle.

B.3.2 For Type 2B, apply the force in accordance with [B.2.2](#) selecting the worst case for the intended age user group.

Measure and record the angle of the seat/stand.

Examine and record whether the extreme parts of the equipment touch the ground.

Annex C (normative)

Determination of freedom from pinch and crush points

C.1 Principle

The support components are loaded with a known force and the compression at the support components is measured. The equipment is moved to its extreme positions and the support components and surrounding part of the equipment are tested to establish whether a 12 mm diameter rod can be inserted during the course of movement.

C.2 Apparatus

C.2.1 Device, capable of applying a force of (695 ± 5) N vertically in the centre line of each seat/standing surface.

C.2.2 Device for Type 2B, capable of applying a force of $(167 \pm 2,1)$ N for age group up to 4 years and/or a force of (279 ± 5) N for age group up to 8 years.

C.2.3 Rod, of 12 mm diameter.

C.3 Procedure

C.3.1 Load the equipment with a force at (695 ± 5) N ([C.2.1](#)) and record whether the supporting component compresses by more than 5 %. For Type 2B, apply the force in accordance with [C.2.2](#) selecting the age group that represents the worst case foreseeable use.

C.3.2 Move the equipment to one of its most extreme positions. Using the rod ([C.2.3](#)) examine the supporting component and the surrounding area to check whether the rod can be inserted.

Repeat the procedure at all of the other extreme positions.

Record whether the rod could be inserted at all extreme positions.

Annex D (normative)

Determination of sideways stability

D.1 Principle

A load is applied and the deviation of the longitudinal axis is measured.

D.2 Apparatus

D.2.1 **Device**, capable of applying a force of (695 ± 5) N horizontally.

D.3 Procedure

Apply a force of (695 ± 5) N horizontally, at a position perpendicular to the centre of the seat/stand position.

If the damping mechanism involves elements that are set into the ground, ensure that the seesaw makes contact with the damping element.

Measure the deviation from the rest position.

Record the results.

<http://www.china-gauges.com/>

Annex E (normative)

Determination of hand support and/or foot rest projection

E.1 Apparatus

A ring gauge in accordance with [Figure E.1](#).

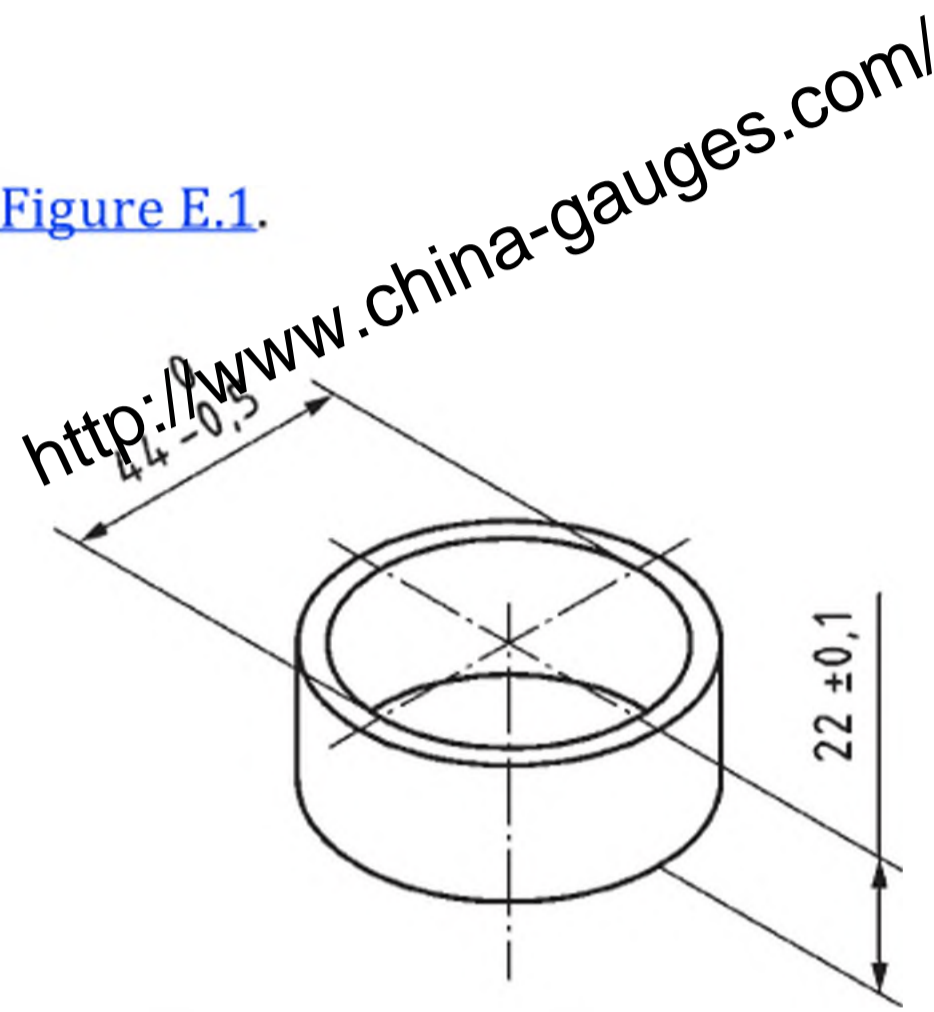

Dimensions in millimetres

Figure E.1 — Ring gauge

E.2 Procedure

Place the gauge (see [Figure E.1](#)) over the projecting end of the hand support or foot rest, as appropriate; apply the gauge only along the centre line of the hand support or foot rest. Determine whether the hand support or foot rest protrudes beyond the outer face of the gauge (see [Figure E.2](#)).

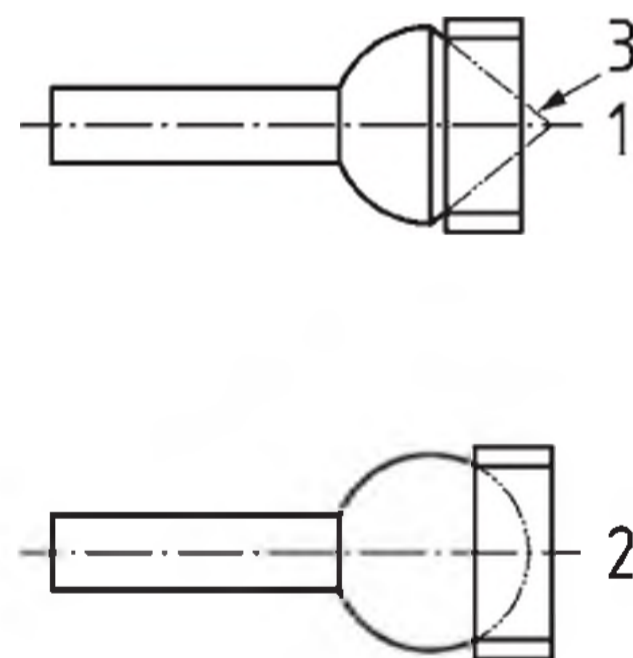

Key	
1	fail
2	pass
3	projecting part

Figure E.2 — Gauge

<http://www.china-gauges.com/>

British Standards Institution (BSI)

BSI is the national body responsible for preparing British Standards and other standards-related publications, information and services.

BSI is incorporated by Royal Charter. British Standards and other standardization products are published by BSI Standards Limited.

About us

We bring together business, industry, government, consumers, innovators and others to shape their combined experience and expertise into standards-based solutions.

The knowledge embodied in our standards has been carefully assembled in a dependable format and refined through our open consultation process. Organizations of all sizes and across all sectors choose standards to help them achieve their goals.

Information on standards

We can provide you with the knowledge that your organization needs to succeed. Find out more about British Standards by visiting our website at bsigroup.com/standards or contacting our Customer Services team or Knowledge Centre.

Buying standards

You can buy and download PDF versions of BSI publications, including British and adopted European and international standards, through our website at bsigroup.com/shop, where hard copies can also be purchased.

If you need international and foreign standards from other Standards Development Organizations, hard copies can be ordered from our Customer Services team.

Copyright in BSI publications

All the content in BSI publications, including British Standards, is the property of and copyrighted by BSI or some person or entity that owns copyright in the information used (such as the international standardization bodies) and has formally licensed such information to BSI for commercial publication and use.

Save for the provisions below, you may not transfer, share or disseminate any portion of the standard to any other person. You may not adapt, distribute, commercially exploit, or publicly display the standard or any portion thereof in any manner whatsoever without BSI's prior written consent.

Storing and using standards

Standards purchased in soft copy format:

- A British Standard purchased in soft copy format is licensed to a sole named user for personal or internal company use only.
- The standard may be stored on more than 1 device provided that it is accessible by the sole named user only and that only 1 copy is accessed at any one time.
- A single paper copy may be printed for personal or internal company use only.

Standards purchased in hard copy format:

- A British Standard purchased in hard copy format is for personal or internal company use only.
- It may not be further reproduced – in any format – to create an additional copy. This includes scanning of the document.

If you need more than 1 copy of the document, or if you wish to share the document on an internal network, you can save money by choosing a subscription product (see 'Subscriptions').

Reproducing extracts

For permission to reproduce content from BSI publications contact the BSI Copyright & Licensing team.

Subscriptions

Our range of subscription services are designed to make using standards easier for you. For further information on our subscription products go to bsigroup.com/subscriptions.

With **British Standards Online (BSOL)** you'll have instant access to over 55,000 British and adopted European and international standards from your desktop. It's available 24/7 and is refreshed daily so you'll always be up to date.

You can keep in touch with standards developments and receive substantial discounts on the purchase price of standards, both in single copy and subscription format, by becoming a **BSI Subscribing Member**.

PLUS is an updating service exclusive to BSI Subscribing Members. You will automatically receive the latest hard copy of your standards when they're revised or replaced.

To find out more about becoming a BSI Subscribing Member and the benefits of membership, please visit bsigroup.com/shop.

With a **Multi-User Network Licence (MUNL)** you are able to host standards publications on your intranet. Licences can cover as few or as many users as you wish. With updates supplied as soon as they're available, you can be sure your documentation is current. For further information, email subscriptions@bsigroup.com.

Revisions

Our British Standards and other publications are updated by amendment or revision.

We continually improve the quality of our products and services to benefit your business. If you find an inaccuracy or ambiguity within a British Standard or other BSI publication please inform the Knowledge Centre.

Useful Contacts

Customer Services

Tel: +44 345 086 9001

Email (orders): orders@bsigroup.com

Email (enquiries): cservices@bsigroup.com

Subscriptions

Tel: +44 345 086 9001

Email: subscriptions@bsigroup.com

Knowledge Centre

Tel: +44 20 8996 7004

Email: knowledgecentre@bsigroup.com

Copyright & Licensing

Tel: +44 20 8996 7070

Email: copyright@bsigroup.com

BSI Group Headquarters

389 Chiswick High Road London W4 4AL UK