

BS EN 61326-2-3:2013



BSI Standards Publication

<http://www.china-gauges.com/>

# Electrical equipment for measurement, control and laboratory use — EMC requirements

Part 2-3: Particular requirements —  
Test configuration, operational conditions  
and performance criteria for transducers with  
integrated or remote signal conditioning  
(IEC 61326-2-3:2012)

**bsi.**

...making excellence a habit.™

### National foreword

This British Standard is the UK implementation of EN 61326-2-3:2013. It is identical to IEC 61326-2-3:2012. It supersedes BS EN 61326-2-3:2006, which will be withdrawn on 14 August 2015.

The UK participation in its preparation was entrusted by Technical Committee GEL/65, Measurement and control, to Subcommittee GEL/65/4, System considerations.

A list of organizations represented on this committee can be obtained on request to its secretary.

This publication does not purport to include all the necessary provisions of a contract. Users are responsible for its correct application.

© The British Standards Institution 2013.

Published by BSI Standards Limited 2013.

ISBN 978 0 580 70407 9

ICS 25.040.40; 33.100.01

### Compliance with a British Standard cannot confer immunity from legal obligations.

This British Standard was published under the authority of the Standards Policy and Strategy Committee on 28 February 2013.

### Amendments issued since publication

Amd. No.	Date	Text affected
----------	------	---------------

---

EUROPEAN STANDARD  
NORME EUROPÉENNE  
EUROPÄISCHE NORM

**EN 61326-2-3**

January 2013

ICS 17.220; 19.080; 25.040.40; 33.100

Supersedes EN 61326-2-3:2006

English version

**Electrical equipment for measurement, control and laboratory use -  
EMC requirements -  
Part 2-3: Particular requirements -  
Test configuration, operational conditions and performance criteria for  
transducers with integrated or remote signal conditioning  
(IEC 61326-2-3:2012)**

Matériel électrique de mesure, de  
commande et de laboratoire -  
Exigences relatives à la CEM -  
Partie 2-3: Exigences particulières -  
Configurations d'essai, conditions de  
fonctionnement et critères de performance  
des transducteurs avec un système de  
conditionnement du signal intégré ou à  
distance  
(CEI 61326-2-3:2012)

Elektrische Mess-, Steuer-, Regel- und  
Laborgeräte -  
EMV-Anforderungen -  
Teil 2-3: Besondere Anforderungen -  
Prüfanordnung, Betriebsbedingungen und  
Leistungsmerkmale für  
Messgrößenumformer mit integrierter oder  
abgesetzter Signalaufbereitung  
(IEC 61326-2-3:2012)

This European Standard was approved by CENELEC on 2012-08-14. CENELEC members are bound to comply with the CEN/CENELEC Internal Regulations which stipulate the conditions for giving this European Standard the status of a national standard without any alteration.

Up-to-date lists and bibliographical references concerning such national standards may be obtained on application to the CEN-CENELEC Management Centre or to any CENELEC member.

This European Standard exists in three official versions (English, French, German). A version in any other language made by translation under the responsibility of a CENELEC member into its own language and notified to the CEN-CENELEC Management Centre has the same status as the official versions.

CENELEC members are the national electrotechnical committees of Austria, Belgium, Bulgaria, Croatia, Cyprus, the Czech Republic, Denmark, Estonia, Finland, Former Yugoslav Republic of Macedonia, France, Germany, Greece, Hungary, Iceland, Ireland, Italy, Latvia, Lithuania, Luxembourg, Malta, the Netherlands, Norway, Poland, Portugal, Romania, Slovakia, Slovenia, Spain, Sweden, Switzerland, Turkey and the United Kingdom.

## CENELEC

European Committee for Electrotechnical Standardization  
Comité Européen de Normalisation Electrotechnique  
Europäisches Komitee für Elektrotechnische Normung

**Management Centre: Avenue Marnix 17, B - 1000 Brussels**

## Foreword

The text of document 65A/629/FDIS, future edition 2 of IEC 61326-2-3, prepared by SC 65A, "System aspects", of IEC TC 65, "Industrial-process measurement, control and automation" was submitted to the IEC-CENELEC parallel vote and approved by CENELEC as EN 61326-2-3:2013.

The following dates are fixed:

- latest date by which the document has to be implemented at national level by publication of an identical national standard or by endorsement (dop) 2013-07-20
- latest date by which the national standards conflicting with the document have to be withdrawn (dvw) 2015-08-14

This document supersedes EN 61326-2-3:2006.

EN 61326-2-3:2013 includes the following significant technical changes with respect to EN 61326-2-3:2006:

– update of the document with respect to EN 61326-1:2013.

EN 61326-2-3:2013 is to be used in conjunction with EN 61326-1:2013 and follows the same numbering of clauses, subclauses, tables and figures.

When a particular subclause of EN 61326-1 is not mentioned in this part, that subclause applies as far as is reasonable. When this standard states "addition", "modification" or "replacement", the relevant text in EN 61326-1 is to be adapted accordingly.

NOTE The following numbering system is used:

- subclauses, tables and figures that are numbered starting from 101 are additional to those in EN 61326-1;
- unless notes are in a new subclause or involve notes in EN 61326-1, they are numbered starting from 101 including those in a replaced clause or subclause;
- additional annexes are lettered AA, BB, etc.

Attention is drawn to the possibility that some of the elements of this document may be the subject of patent rights. CENELEC [and/or CEN] shall not be held responsible for identifying any or all such patent rights.

This document has been prepared under a mandate given to CENELEC by the European Commission and the European Free Trade Association, and supports essential requirements of EU Directive(s).

For the relationship with EU Directive(s) see informative Annex ZZ, which is an integral part of this document.

## Endorsement notice

The text of the International Standard IEC 61326-2-3:2012 was approved by CENELEC as a European Standard without any modification.

**Annex ZA**  
(normative)

**Normative references to international publications  
with their corresponding European publications**

The following documents, in whole or in part, are normatively referenced in this document and are indispensable for its application. For dated references, only the edition cited applies. For undated references, the latest edition of the referenced document (including any amendments) applies.

NOTE When an international publication has been modified by common modifications, indicated by (mod), the relevant EN/HD applies.

*Annex ZA of EN 61326-1:2013 applies, except as follows:*

<u>Publication</u>	<u>Year</u>	<u>Title</u>	<u>EN/HD</u>	<u>Year</u>
<i>Addition:</i>				
IEC 61326-1	2012	Electrical equipment for measurement, control and laboratory use - EMC requirements - Part 1: General requirements	EN 61326-1	2013

## **Annex ZZ** (informative)

### **Coverage of Essential Requirements of EU Directives**

This European Standard has been prepared under a mandate given to CENELEC by the European Commission and the European Free Trade Association and within its scope the standard covers protection requirements of Annex I, Article 1 of the EC Directive 2004/108/EC.

Compliance with this standard provides one means of conformity with the specified essential requirements of the Directive[s] concerned.

NOTE Other requirements and other EU Directives may be applicable to the products falling within the scope of this standard.

<http://www.china-gauges.com/>

## CONTENTS

1	Scope	6
2	Normative references	8
3	Terms and definitions	8
4	General	9
5	EMC test plan	9
5.1	General	9
5.2	Configuration of EUT during testing	9
5.3	Operation conditions of EUT during testing	9
5.4	Specification of functional performance	10
5.5	Test description	10
6	Immunity requirements	10
6.1	Conditions during the tests	10
6.2	Immunity test requirements	10
6.3	Random aspects	11
6.4	Performance criteria	11
7	Emission requirements	12
7.1	Conditions during measurements	12
7.2	Emission limits	12
8	Test results and test report	12
9	Instructions for use	12
	Annex A (normative) Immunity test requirements for portable test and measurement equipment powered by battery or from the circuit being measured	13
	Annex AA (normative) Additional requirements and exceptions for specific types of transducers – Transducers for measurement of tension and compressive forces (force transducers)	14
	Annex BB (normative) Additional requirements and exceptions for specific types of transducers – Transducers for measurement of pressure (pressure transducers)	17
	Annex CC (normative) Additional requirements and exceptions for specific types of transducers – Transducers for measurement of temperature (temperature transducer)	19
	Bibliography	22
	Figure 101 – Example of a transducer with integrated signal conditioning	7
	Figure 102 – Example of a transducer with remote signal conditioning	7
	Figure AA.1 – Example of the configuration of a force transducer with remote signal conditioning	15
	Figure BB.1 – Example of the configuration of a pressure transducer	18
	Figure CC.1 – Example of the configuration of a temperature transducer with sensor and signal conditioning in the same housing	20
	Figure CC.2 – Example of the configuration of a temperature transducer with remote signal conditioning	20

Table 101 – Performance criteria for the different functions ..... 11  
Table AA.1 – Circuitry actions for generating an output signal for simulation of a  
mechanical load on the transducer.....<sup>15</sup>

<http://www.china-gauges.com/>



**ELECTRICAL EQUIPMENT FOR MEASUREMENT,  
CONTROL AND LABORATORY USE –  
EMC REQUIREMENTS –**

**Part 2-3: Particular requirements –  
Test configuration, operational conditions and performance  
criteria for transducers with integrated or remote signal conditioning**

## 1 Scope

In addition to the requirements of IEC 61326-1, this part specifies more detailed test configurations, operational conditions and performance criteria for transducers with integrated or remote signal conditioning.

This standard applies only to transducers characterized by their ability to transform, with the aid of an auxiliary energy source, a non-electric quantity to a process-relevant electrical signal, and to output the signal at one or more ports. This standard includes transducers for electrochemical and biological measured quantities.

The transducers covered by this standard may be powered by a.c. or d.c. voltage and/or by battery or with internal power supply.

Transducers referred to by this standard comprise at least the following items (see Figures 101 and 102):

- one or more elements for transforming a non-electrical input quantity to an electrical quantity;
- a transmission link for transferral of the electrical quantity to a component for signal conditioning;
- a unit for signal conditioning that converts the electrical quantity to a process-relevant electrical signal;
- an enclosure for enclosing the above-stated components fully or in parts.

Transducers referred to by this standard may also have the following items (see Figures 101 and 102):

- a communication and control unit;
- a display unit;
- control elements such as keys, buttons, switches, etc.;
- transducer output signals (for example, switch outputs, alarm outputs) which are clearly assigned to the input signal(s);
- transducers with signal conditioning which may be integrated or remote.

The manufacturer specifies the environment for which the product is intended to be used and utilizes the corresponding test levels of IEC 61326-1.

Additional requirements and exceptions for specific types of transducers are given in the annexes to this standard.

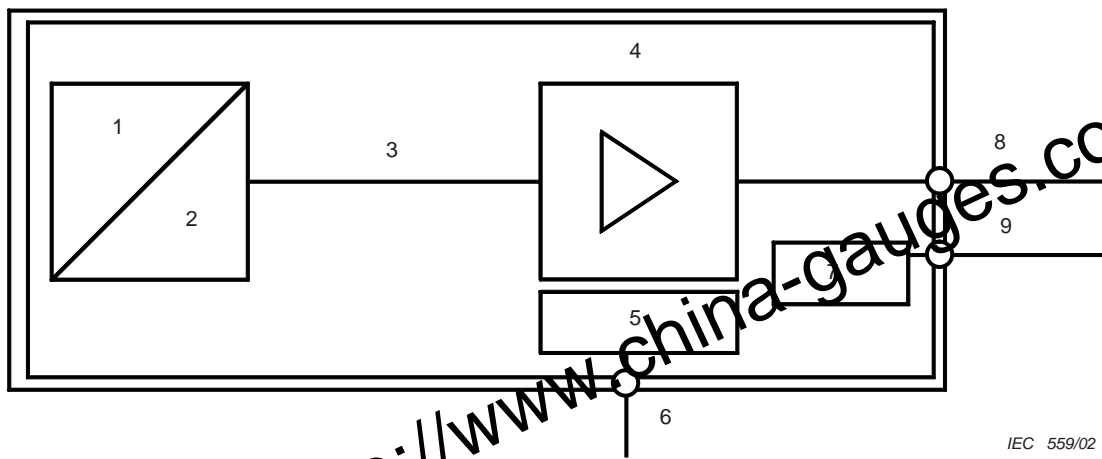

IEC 559/02

**Key**

- 1 Non-electrical quantity
- 2 Electrical quantity
- 3 Transmission link
- 4 Signal conditioning
- 5 Communication and control unit
- 6 Input/output ports
- 7 Power supply
- 8 Signal port
- 9 AC/DC power port

**Figure 101 – Example of a transducer with integrated signal conditioning**

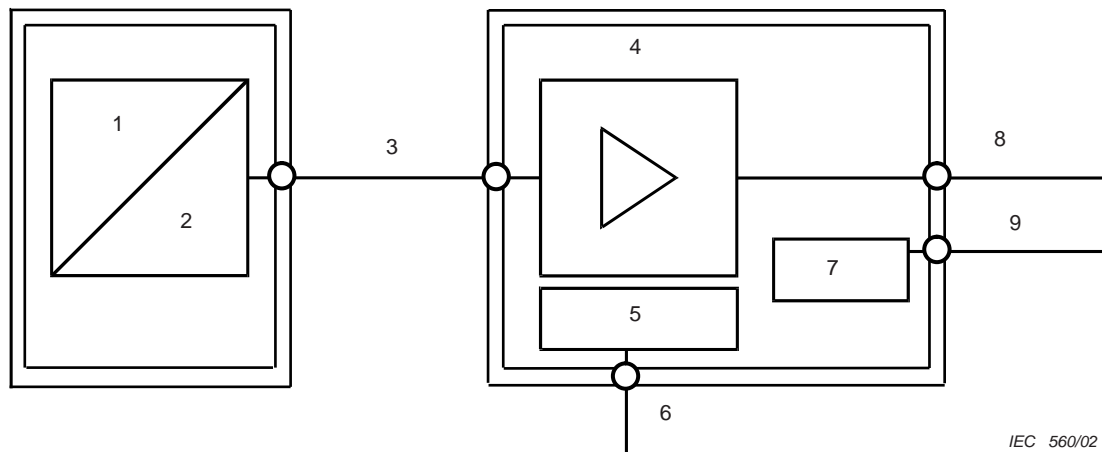

IEC 560/02

**Key**

- 1 Non-electrical quantity
- 2 Electrical quantity
- 3 Transmission link
- 4 Signal conditioning
- 5 Communication and control unit
- 6 Input/output ports
- 7 Power supply
- 8 Signal port
- 9 AC/DC power port

**Figure 102 – Example of a transducer with remote signal conditioning**

## 2 Normative references

The following documents, in whole or in part, are normatively referenced in this document and are indispensable for its application. For dated references, only the edition cited applies. For undated references, the latest edition of the referenced document (including any amendments) applies.

Clause 2 of IEC 61326-1:2012 applies, except as follows:

*Addition:*

IEC 61326-1:2012, *Electrical equipment for measurement, control and laboratory use – EMC requirements – Part 1: General requirements*

## 3 Terms and definitions

For the purposes of this document, the terms and definitions of IEC 61326-1 apply, except as follows.

*Addition:*

### 3.101 transducer with integrated signal conditioning

transducer in which all components for signal conditioning are integrated in the enclosure (see Figure 101)

### 3.102 transducer with remote signal conditioning

transducer whose components for signal conditioning are installed in separate enclosures (see Figure 102)

### 3.104 transmission link

connection between the individual components of a transducer with remote signal conditioning

### 3.105 (nominal) range

range of indications obtainable with a particular setting of the controls of a measuring instrument

Note 1 to entry: The nominal range is normally stated in terms of its lower and upper limits. Where the lower limit is zero, the nominal range is commonly stated solely in terms of its upper limit.

[SOURCE: IEC 60050-300:2001, 311-03-14]

### 3.106 measuring range (of a transducer)

range defined by two values of the measured quantity within which the relationship between the output and input signals complies with the accuracy requirements

[SOURCE: IEC 60050-300:2001, 314-04-04, modified]

Note 1 to entry: For a 4 mA to 20 mA system, the output current 4 mA represents the lower limit for the measured quantity and 20 mA represent the upper limit.

### 3.107 span

algebraic difference between the values of the upper and lower limits of the measuring range

[SOURCE: IEC 60050-300:2001, 311-03-13]

### **3.108**

#### **intrinsic uncertainty**

uncertainty of a measuring instrument when used under reference conditions

Note 1 to entry: This term is used in the “uncertainty” approach

[SOURCE: IEC 60050-300:2001, 311-03-09]

## **4 General**

Clause 4 of IEC 61326-1:2012 applies.

## **5 EMC test plan**

### **5.1 General**

Subclause 5.1 of IEC 61326-1:2012 applies.

### **5.2 Configuration of EUT during testing**

Subclause 5.2 of IEC 61326-1:2012 applies, except as follows.

#### **5.2.1 General**

Subclause 5.2.1 of IEC 61326-1:2012 applies, except as follows:

*Addition:*

A system for monitoring the behaviour of the EUT and for registering the output values shall be designed in such a way that the electromagnetic compatibility characteristics of the EUT are not impaired. The monitoring system shall also be designed such that its response is not affected by the immunity tests. The input impedance of the monitoring system shall correspond to the terminating impedance of the transducer, specified by the manufacturer. The distance between the monitoring system and the EUT should be at least 1,5 m.

The measurement uncertainty and the bandwidth of the monitoring system shall be adapted to the characteristics of the transducer.

Transmission links are considered as separate input and output lines.

The tests shall be conducted in compliance with the environmental conditions for the transducer specified by the manufacturer and using the specified supply voltage.

In the case of battery-operated transducers that can also be used when connected with a power supply, both operating modes (stand-alone and externally supplied) shall be tested.

In cases in which the manufacturer's installation instructions stipulate the use of external protective equipment or particular protective measures that are explicitly stated in the operating manual, the test requirements given in this part of the standard shall be applied for use together with the external protective equipment or measures.

### **5.3 Operation conditions of EUT during testing**

Subclause 5.3 of IEC 61326-1:2012 applies.

<http://www.china-gauges.com/>

#### 5.4 Specification of functional performance

Subclause 5.4 of IEC 61326-1:2012 applies.

#### 5.5 Test description

Subclause 5.5 of IEC 61326-1:2012 applies.

### 6 Immunity requirements

#### 6.1 Conditions during the tests

Subclause 6.1 of IEC 61326-1:2012 applies except as follows:

*Addition:*

Transducers shall be operated during the test with all lines connected, provided the ports do not have functions that contravene the definition of a transducer's function.

Configurations with alternative ports shall be tested separately.

Transducers shall be set to the most sensitive ranges or combination of ranges unless other ranges are known to provide worst-case immunity results within normal application.

Only operational functions compliant with the specified use under the nominal conditions are permitted. Defined functions that cannot be set under electromagnetic compatibility test conditions shall be simulated by appropriate measures. This shall be done in such a way that the electromagnetic compatibility behaviour of the transducer is not affected.

Measurement and supply circuits shall be grounded in accordance with the manufacturer's specifications. If no such specifications are given, the tests shall be carried out with the circuits grounded and with the circuits ungrounded.

#### 6.2 Immunity test requirements

Subclause 6.2 of IEC 61326-1:2012 applies except as follows:

*Addition:*

After or during each test, the function of the transducer shall be tested.

Power inputs for voltages up to 75 V d.c. or voltages up to 50 V a.c. that are fed in a single cable together with the input and output ports are tested as input and output ports.

Power inputs for voltages up to 75 V d.c. or voltages up to 50 V a.c. with superimposed output signals (for example, 4 mA to 20 mA current loop with two-wire technology) are also tested as input/output ports.

The transmission link of a transducer with remote signal conditioning is tested as an input/output port.

If there are any manufacturer's specifications present to the insulation resistance then these shall be checked once again after ESD, fast transient (burst) and surge tests. If the manufacturer's specifications are not satisfied, the transducer is deemed to have failed the EMC tests.

<http://www.china-gauges.com/>

### 6.3 Random aspects

Subclause 6.3 of IEC 61326-1:2012 applies.

### 6.4 Performance criteria

Subclause 6.4 of IEC 61326-1:2012 applies except as follows:

*Addition:*

The performance criteria are used to assess the defined functions of a transducer under the effects of external electromagnetic disturbances. Since a transducer is often part of a chain of functions in a large process, effects on the overall process due to malfunctions of a transducer caused by external interference factors cannot be predicted without great difficulty. For this reason, it is particularly important that the behaviour of transducers under the influence of electromagnetic disturbances is described with performance criteria by the manufacturer.

Table 101 describes the permissible effects of a disturbance on the different functions of a transducer with regard to the required performance criteria.

**Table 101 – Performance criteria for the different functions**

Function	Additional particular performance criteria		
	for performance criterion A	for performance criterion B	for performance criterion C
<b>Main function</b> <sup>a</sup>	The deviations during the test are within the limit values for intrinsic uncertainty specified and documented by the manufacturer	The deviations during the test are within the limit values for additional deviations specified and documented by the manufacturer	The deviations during the test may be outside the limit values specified and documented by the manufacturer. After the test, the measured values are within the specified range.  The manufacturer shall specify the time that is required to regain normal function after the end of the test.
<b>Process communication</b>	Communication as intended	Temporary interference of the communication is permitted during the test.	Interference of the communication is permitted during the test.  The manufacturer shall specify the time that is required to regain normal function after the end of the test.
<b>Alarm function</b>	No malfunctions permitted	Temporary interference of the communication is permitted during the test.	Malfunctions are permitted.  The manufacturer shall specify the time that is required to regain normal function after the end of the test.

<sup>a</sup> The main function of a measuring transducer is to transform a non-electrical quantity into a process-relevant signal as shown in Figures 101 and 102.

## **7 Emission requirements**

### **7.1 Conditions during measurements**

Subclause 7.1 of IEC 61326-1:2012 applies except as follows:

*Addition:*

The additions made in Clauses 5 and 6 shall be taken into account.

### **7.2 Emission limits**

Subclause 7.2 of IEC 61326-1:2012 applies.

## **8 Test results and test report**

Clause 8 of IEC 61326-1:2012 applies.

## **9 Instructions for use**

Clause 9 of IEC 61326-1:2012 applies.

<http://www.china-gauges.com/>

**Annex A**  
(normative)

**Immunity test requirements for portable test and measurement  
equipment powered by battery or from the circuit being measured**

Annex A of IEC 61326-1:2012 does not apply.

*Additional annexes:*

<http://www.china-gauges.com/>



## Annex AA (normative)

### Additional requirements and exceptions for specific types of transducers – Transducers for measurement of tension and compressive forces (force transducers)

#### AA.1 General considerations

In addition to the requirements of the main part of this standard, this Annex AA describes particular EMC requirements for force transducers that permit static measurement quantities.

Force transducers comprise at least the following components:

- a deflection unit that records mechanical forces as input quantities;
- one or more converting elements for generating electrical signals proportional to the mechanical input quantities;
- a measurement signal amplifier for processing the electrical signals into process-relevant signals.

#### AA.2 Test configuration

The force transducer shall be tested in the position specified by the manufacturer (see Figure AA.1).

If no installation position is specified by the manufacturer, the transducer shall be positioned in such a way that the force is applied vertically.

The grounding of the power supply and force transducer shall comply with the manufacturer's specifications. If none are given, the power supply for voltages less than 70 V d.c. shall be grounded and the transducer shall be tested both grounded and insulated from ground.

Connections to functional earth shall only be made at terminals of the force transducer intended for that purpose.

If the ports are implemented in the form of plug-in connectors and if they have a terminal for a cable shield then the shield shall be connected with the functional earth port. Preinstalled cable connectors with shielding shall be connected accordingly.

The mounting parts for securing the transducer in a fixed position and the mounting plate shall not be made of conductive material unless specified otherwise by the manufacturer. The outer distance A between the components should not be greater than 1 m.

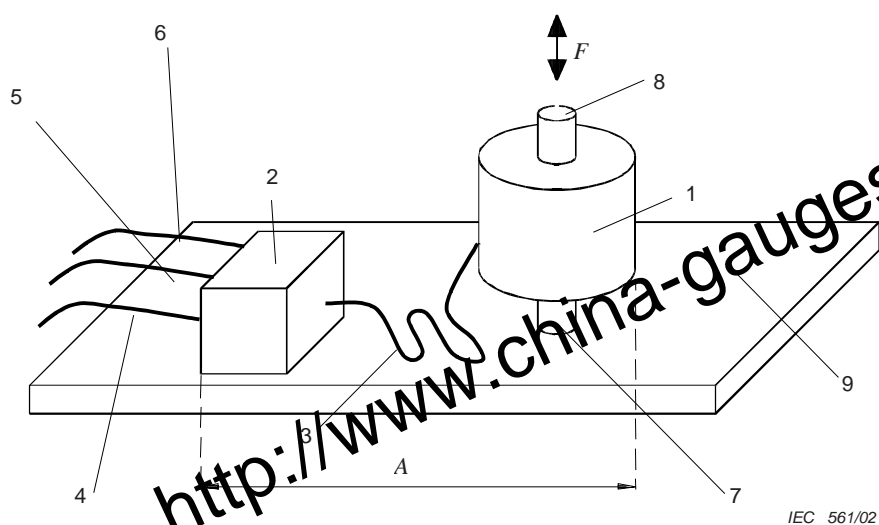

IEC 561/02

**Key**

- 1 Deflection unit
- 2 Remote signal conditioning
- 3 Transmission link
- 4 AC/DC mains port
- 5 Input/output port
- 6 Measurement output port
- 7 Mounting part
- 8 Load button
- 9 Mounting plate
- $F$  Tension/compressive force
- A Outer distance between deflection unit and remote signal conditioning (max. 1 m)

**Figure AA.1 – Example of the configuration of a force transducer with remote signal conditioning**

**AA.3 Operation conditions**

The EUT shall be operated with the specified rated supply voltage. If the maximum rated supply voltage differs from the minimum rated supply voltage by more than a factor of 2, the EMC tests conducted on the power input lines shall be performed at both the minimum and the maximum rated supply voltages.

Force transducers are tested under static, mechanical load.

If a mechanical load cannot be applied to the force transducer in the test environment, an output signal may be generated using suitable circuitry connected to the transducer elements. This circuitry shall be connected directly to the transducer elements in the transducer housing. The application of each circuitry action shall be described and justified in the test report.

Example for possible circuitry actions are listed in Table AA.1.

**Table AA.1 – Circuitry actions for generating an output signal for simulation of a mechanical load on the transducer**

Transducer technology	Circuitry actions used for simulation
Strain gauge	Detune the measuring bridge with fixed-value resistors
Capacitive elements	Detune the measuring bridge with capacitors and/or fixed-value resistors in the case of half-bridges

The force shall be between 30 % and 70 % of the nominal force range. In the case of an expanded measurement range, the main function output signal should also be within 30 % and 70 % of the output signal operating range. In the case of a  $\pm$  range, zero values – for example 0,0 mA or 0,0 V – should not be chosen.

An alarm function shall be configured in such a way that the difference between the actual measuring value and the adjusted alarm value corresponds to twice of the specified accuracy allowed for the tested measurement span.

Two situations shall be tested:

- a) the adjusted alarm value is above the actual measuring value;
- b) the adjusted alarm value is below the actual measuring value.

If the initiation threshold value of the alarm function is within 30 % to 70 % of the rated test value range, it can be tested together with the other outputs.

**Annex BB**  
(normative)

**Additional requirements and exceptions  
for specific types of transducers –  
Transducers for measurement of pressure  
(pressure transducers)**

**BB.1 General considerations**

In addition to the requirements of the main part of this standard, this Annex BB describes particular EMC requirements for pressure transducers.

Pressure transducers consist of at least the following:

- a process connection for pressure-sealed connection to the process;
- a sensor element for conversion of pressure to a quantity that can be electrically processed;
- a signal conditioning unit for formatting, linearizing, amplifying and converting the electrical quantity to a process-compliant signal.

This annex does not apply to pressure measurement equipment operating purely on a mechanical basis – for example, spring-tube manometers with limit switches.

**BB.2 Test configuration**

All tests shall be carried out in the pressure transducer position specified by the manufacturer (see Figure BB.1).

If no position is specified, the tests shall be performed in the position considered to be the least favourable and noted in the test report.

Components for pressure measurement to a test object should affect the test configuration as little as possible. For this reason, the dimensions of metallic pressure adapters should not be more than twice the size of the EUT. Pipes to pressure connection, pressure controllers and the used media should be electrically insulated if conductive pipes or media may influence the test result.

The tests shall be carried out with all the electrical connection elements specified by the manufacturer fully assembled and connected.

The grounding of the transducer and the power supply shall be in accordance with the manufacturers specifications.

If not specified by the manufacturer, the EUT shall be prepared in the following way:

- if the process connection is made of metal, it shall be grounded. Sealants are not allowed to impair the resistance to the grounding terminal;
- if a terminal is provided for functional grounding, it shall be grounded;
- if terminals have an option for a cable shield connection, the option shall be used for connecting the shield;
- the power supply shall be insulated from the ground.

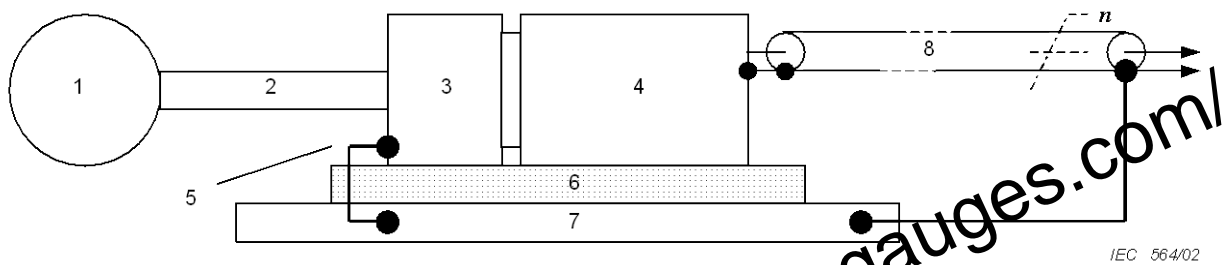

**Key**

- 1 Process medium
- 2 Pipe
- 3 Pressure adapter
- 4 Pressure transducer
- 5 Ground connection
- 6 Insulated spacer

NOTE See relevant basic standards for the height of the insulated spacer.

- 7 Reference ground
- 8 Connecting  $n$  line(s)

**Figure BB.1 – Example of the configuration of a pressure transducer**

### BB.3 Operation conditions

The EUT shall be operated with the specified rated supply voltage. If the maximum rated supply voltage differs from the minimum rated supply voltage by more than a factor of 2, the conducted EMC tests on the power input lines shall be performed at both the minimum and the maximum rated supply voltages.

The pressure shall be between 30 % and 70 % of the nominal pressure range. In the case of an expanded measurement range, the main function output signal should also be within 30 % and 70 % of the output signal operating range. In the case of a  $\pm$  range, zero values – for example, 0,0 mA or 0,0 V – should not be chosen.

Adjustable pressure transducers shall be set in accordance with the manufacturer's specifications. If no manufacturer specifications are given, use the following settings:

- most sensitive measurement range;
- minimum time constant/response time;
- highest data transfer rate.

## Annex CC (normative)

### Additional requirements and exceptions for specific types of transducers – Transducers for measurement of temperature (temperature transducer)

#### CC.1 General considerations

In addition to the requirements of the main part of this standard, this Annex CC describes particular EMC requirements for temperature transducers.

Temperature transducers comprise at least the following components:

- one or more temperature sensors (for example, thermocouple, PT-100);
- a signal conditioning unit for formatting, linearizing, amplifying and converting the electrical input signal to a process-compliant signal;
- signal port with attached cable for signal transfer (for example, two-wire 4 mA to 20 mA link).

The temperature transducer may also have the following components:

- one or more transmission links between temperature sensor and processing unit;
- port for separate power supply.

#### CC.2 Test configuration

The test setup shall be as close as possible to real installations. Deviations from the test set-up described in the basic standards cited that might be necessary due to special demands of temperature transducers shall be described and justified in the test report. The cable types shall be chosen according to the manufacturers' installation guides. If no special cables are prescribed, common unshielded and untwisted cables shall be used in the test setup.

For analogue output signals, a load within the specification of the manufacturer shall be connected, for which the EUT is expected to be most susceptible to EMC phenomena.

If the temperature transducer is only used and delivered as a single unit (sensor and processing unit within the same housing), it shall be tested in this configuration (see test setup in Figure CC.1). In all other cases, the test setup in Figure CC.2 shall be used. The length of the cables shall be in accordance with the basic standards. The tests shall be carried out with all electrical connection elements fully assembled and connected as specified by the manufacturer. The temperature transducer and power supply shall be connected to ground in accordance with the specifications of the manufacturer.

The room temperature should be used as the reference measurement quantity. Care shall be taken that the temperature is constant within an appropriate temperature interval to evaluate the performance of the transducer. If this is not possible (for example, due to the measuring range of the transducer), the sensor of the transducer shall be mounted on a suitable medium representing the process temperature or the room temperature shall be taken into account via a separate temperature measurement. Simulations (networks of resistors and/or other passive components or batteries) can be used instead of a passive sensor or thermocouple, if equivalence of the high-frequency characteristics can be proved so as to ensure a similar electromagnetic behaviour.

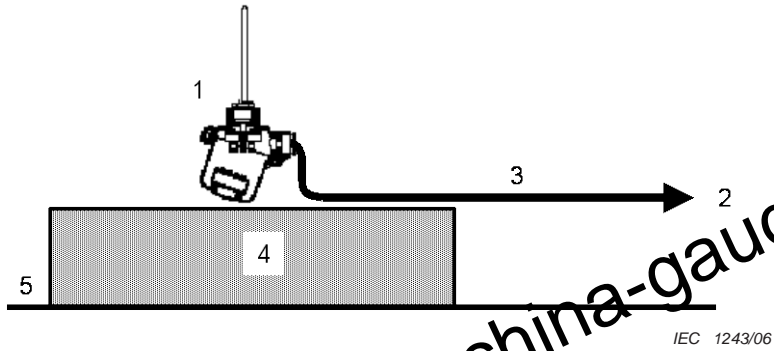

**Key**

- 1 Temperature transducer (orientation of transducer only as an example)
- 2 Auxiliary equipment (for example, power supply, signal evaluation, or system for transmission of the signal)
- 3 Link cable, unshielded, untwisted, if not specified otherwise
- 4 Insulated spacer (dimension according to the relevant basic standard)
- 5 Reference ground

**Figure CC.1 – Example of the configuration of a temperature transducer with sensor and signal conditioning in the same housing**

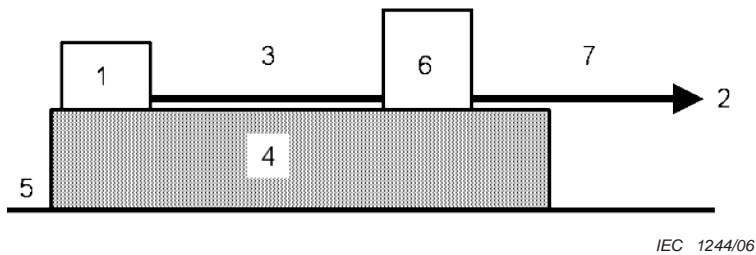

**Key**

- 1 Temperature sensor
- 2 Auxiliary equipment (for example, power supply, signal evaluation)
- 3 Link cable, unshielded, untwisted, if not specified otherwise
- 4 Insulated spacer (dimension according to the relevant basic standard)
- 5 Reference ground
- 6 Signal conditioning unit of the transducer
- 7 Link cable, unshielded, untwisted, if not specified otherwise

**Figure CC.2 – Example of the configuration of a temperature transducer with remote signal conditioning**

### CC.3 Operation conditions

The EUT shall be operated with the specified rated supply voltage. If the maximum rated supply voltage differs from the minimum rated supply voltage by more than a factor of 2, the EMC tests conducted on the power input lines shall be performed at both the minimum and the maximum rated supply voltages.

The transducer shall be adjusted so that at the applied temperature, a transducer output signal of 40 % to 60 % of the output signal range is generated (for example, 12 mA of a 4 mA to 20 mA system). In the case of a signed output range, zero values – for example, 0,0 mA or 0,0 V – shall not be chosen.

The following settings shall be used, if not otherwise specified by the manufacturer:

- most sensitive measurement range;
- minimum time constant/response time;
- highest data rate.

An alarm function, if available, shall be configured as defined by the manufacturer. If no definition is given by the manufacturer the alarm function shall be configured in such a way that the difference between the actual measuring value and the adjusted alarm value corresponds to the precision of the device.

Two situations shall be tested:

- 1) the adjusted alarm value is above the actual measuring value;
- 2) the adjusted alarm value is below the actual measuring value.

If the initiation threshold value of the alarm function is within 40 % to 60 % of the chosen output signal range, the alarm function can be tested together with the other functions.



## Bibliography

IEC 60050 (all parts), *International Electrotechnical Vocabulary* (available at  
<<http://www.electropedia.org>>)

---

<http://www.china-gauges.com/>

<http://www.china-gauges.com/>

<http://www.china-gauges.com/>

# British Standards Institution (BSI)

BSI is the national body responsible for preparing British Standards and other standards-related publications, information and services.

BSI is incorporated by Royal Charter. British Standards and other standardization products are published by BSI Standards Limited.

## About us

We bring together business, industry, government, consumers, innovators and others to shape their combined experience and expertise into standards-based solutions.

The knowledge embodied in our standards has been carefully assembled in a dependable format and refined through our open consultation process. Organizations of all sizes and across all sectors choose standards to help them achieve their goals.

## Information on standards

We can provide you with the knowledge that your organization needs to succeed. Find out more about British Standards by visiting our website at [bsigroup.com/standards](http://bsigroup.com/standards) or contacting our Customer Services team or Knowledge Centre.

## Buying standards

You can buy and download PDF versions of BSI publications, including British and adopted European and international standards, through our website at [bsigroup.com/shop](http://bsigroup.com/shop), where hard copies can also be purchased.

If you need international and foreign standards from other Standards Development Organizations, hard copies can be ordered from our Customer Services team.

## Subscriptions

Our range of subscription services are designed to make using standards easier for you. For further information on our subscription products go to [bsigroup.com/subscriptions](http://bsigroup.com/subscriptions).

With **British Standards Online (BSOL)** you'll have instant access to over 55,000 British and adopted European and international standards from your desktop. It's available 24/7 and is refreshed daily so you'll always be up to date.

You can keep in touch with standards developments and receive substantial discounts on the purchase price of standards, both in single copy and subscription format, by becoming a **BSI Subscribing Member**.

**PLUS** is an updating service exclusive to BSI Subscribing Members. You will automatically receive the latest hard copy of your standards when they're revised or replaced.

To find out more about becoming a BSI Subscribing Member and the benefits of membership, please visit [bsigroup.com/shop](http://bsigroup.com/shop).

With a **Multi-User Network Licence (MUNL)** you are able to host standards publications on your intranet. Licences can cover as few or as many users as you wish. With updates supplied as soon as they're available, you can be sure your documentation is current. For further information, email [bsmusales@bsigroup.com](mailto:bsmusales@bsigroup.com).

## BSI Group Headquarters

389 Chiswick High Road London W4 4AL UK

## Revisions

Our British Standards and other publications are updated by amendment or revision.

We continually improve the quality of our products and services to benefit your business. If you find an inaccuracy or ambiguity within a British Standard or other BSI publication please inform the Knowledge Centre.

## Copyright

All the data, software and documentation set out in all British Standards and other BSI publications are the property of and copyrighted by BSI, or some person or entity that owns copyright in the information used (such as the international standardization bodies) and has formally licensed such information to BSI for commercial publication and use. Except as permitted under the Copyright, Designs and Patents Act 1988 no extract may be reproduced, stored in a retrieval system or transmitted in any form or by any means – electronic, photocopying, recording or otherwise – without prior written permission from BSI. Details and advice can be obtained from the Copyright & Licensing Department.

## Useful Contacts:

### Customer Services

**Tel:** +44 845 086 9001

**Email (orders):** [orders@bsigroup.com](mailto:orders@bsigroup.com)

**Email (enquiries):** [cservices@bsigroup.com](mailto:cservices@bsigroup.com)

### Subscriptions

**Tel:** +44 845 086 9001

**Email:** [subscriptions@bsigroup.com](mailto:subscriptions@bsigroup.com)

### Knowledge Centre

**Tel:** +44 20 8996 7004

**Email:** [knowledgecentre@bsigroup.com](mailto:knowledgecentre@bsigroup.com)

### Copyright & Licensing

**Tel:** +44 20 8996 7070

**Email:** [copyright@bsigroup.com](mailto:copyright@bsigroup.com)