

INTERNATIONAL
STANDARD

ISO
4975

First edition
2022-06

**Railway applications — Braking
system — Quality of compressed air
for pneumatic apparatus and systems**

*Applications ferroviaires — Système de freinage — Qualité de l'air
comprimé destiné aux appareils et systèmes pneumatiques*



Reference number
ISO 4975:2022(E)

© ISO 2022



COPYRIGHT PROTECTED DOCUMENT

© ISO 2022

All rights reserved. Unless otherwise specified, or required in the context of its implementation, no part of this publication may be reproduced or utilized otherwise in any form or by any means, electronic or mechanical, including photocopying, or posting on the internet or an intranet, without prior written permission. Permission can be requested from either ISO at the address below or ISO's member body in the country of the requester.

ISO copyright office
CP 401 • Ch. de Blandonnet 8
CH-1214 Vernier, Geneva
Phone: +41 22 749 01 11
Email: copyright@iso.org
Website: www.iso.org

Published in Switzerland

Contents

Page

Foreword	iv
Introduction	v
1 Scope	1
2 Normative references	1
3 Terms and definitions	1
4 Units and abbreviated terms	2
4.1 Units.....	2
4.2 Abbreviated terms.....	2
5 Compressed air system	2
5.1 General.....	2
5.2 Breakdown of the system into functional units.....	2
6 Characteristics of the devices constituting the functional units	3
6.1 Air generation and treatment unit (AGTU).....	3
6.1.1 Air intake.....	3
6.1.2 Production of compressed air.....	3
6.1.3 Treatment of compressed air.....	3
6.2 Compressed air storage and distribution.....	3
6.3 Use of compressed air for the brake.....	3
6.4 Use of compressed air for auxiliary devices.....	4
7 Determination of the air quality classes	4
8 Air quality classes	5
8.1 Reference conditions.....	5
8.2 Characteristics of quality classes.....	6
8.3 Designation of the compressed air purity.....	7
8.4 Application to the pneumatic system of a rail vehicle.....	8
Annex A (informative) Contaminants	9
Annex B (informative) Demonstration of air quality during life cycle	10
Annex C (informative) Example for temperature range	12
Bibliography	13

Foreword

ISO (the International Organization for Standardization) is a worldwide federation of national standards bodies (ISO member bodies). The work of preparing International Standards is normally carried out through ISO technical committees. Each member body interested in a subject for which a technical committee has been established has the right to be represented on that committee. International organizations, governmental and non-governmental, in liaison with ISO, also take part in the work. ISO collaborates closely with the International Electrotechnical Commission (IEC) on all matters of electrotechnical standardization.

The procedures used to develop this document and those intended for its further maintenance are described in the ISO/IEC Directives, Part 1. In particular, the different approval criteria needed for the different types of ISO documents should be noted. This document was drafted in accordance with the editorial rules of the ISO/IEC Directives, Part 2 (see www.iso.org/directives).

Attention is drawn to the possibility that some of the elements of this document may be the subject of patent rights. ISO shall not be held responsible for identifying any or all such patent rights. Details of any patent rights identified during the development of the document will be in the Introduction and/or on the ISO list of patent declarations received (see www.iso.org/patents).

Any trade name used in this document is information given for the convenience of users and does not constitute an endorsement.

For an explanation of the voluntary nature of standards, the meaning of ISO specific terms and expressions related to conformity assessment, as well as information about ISO's adherence to the World Trade Organization (WTO) principles in the Technical Barriers to Trade (TBT), see www.iso.org/iso/foreword.html.

This document was prepared by Technical Committee ISO/TC 269, *Railway applications*, Subcommittee SC 2, *Rolling stock*.

Any feedback or questions on this document should be directed to the user's national standards body. A complete listing of these bodies can be found at www.iso.org/members.html.

Introduction

The quality of the compressed air is determined from the quality classes specified in this document, derived from ISO 8573-1:2010.

This document is dedicated to railway specific applications and special need for air generation and treatment units (AGTUs) and air treatment units.

Railway applications — Braking system — Quality of compressed air for pneumatic apparatus and systems

1 Scope

This document defines the quality classes of compressed air produced by air generation and treatment units (AGTUs) and/or used in pneumatic apparatus and systems of rail vehicles.

This document is applicable to compressed AGTUs and also to all pneumatic equipment and systems of rail vehicles.

2 Normative references

The following documents are referred to in the text in such a way that some or all of their content constitutes requirements of this document. For dated references, only the edition cited applies. For undated references, the latest edition of the referenced document (including any amendments) applies.

ISO 8573 (all parts), *Compressed air — Contaminant measurement*

3 Terms and definitions

For the purposes of this document, the terms and definitions given in ISO 8573-1 and the following apply.

ISO and IEC maintain terminology databases for use in standardization at the following addresses:

- ISO Online browsing platform: available at <https://www.iso.org/obp>
- IEC Electropedia: available at <https://www.electropedia.org/>

3.1

coalescence

process in which liquid suspended particles group together to form larger particles

3.2

filter

apparatus for separating contaminants from a fluid vein where they are suspended

3.3

contaminant

substances or combinations of solids, liquids or gaseous materials that can adversely affect a system

3.4

condensate

liquid formed by condensation

3.5

ambient temperature

temperature around the air generation and treatment unit (AGTU)

Note 1 to entry: See also [Figure 2](#), position 16 in the key.

4 Units and abbreviated terms

4.1 Units

This document uses SI units. However, in accordance with standard railway practice with regard to compressed air, some non-SI units are used, such as:

- for pressure indication, the unit used is “bar”: 1 bar = 10⁵ Pa;
- for volume indication, the unit used is “litre”: 1 l = 10⁻³ m³.

Units used for the various contaminants are given in the [Table 1](#). For further specification of contaminants, see [Annex A](#).

Table 1 — Units used for the various contaminants

Contaminant	Dewpoint under pressure °C	Particle size or droplets (grain size) µm	Vapour pressure mbar	Mass concentration mg/m ³	Relative vapour pressure -
Particles:					
— size		X			
— mass concentration				X	
Water:					
— liquid				X	
— vapour	X		X	X	X
Oil:					
— liquid		X		X	
— vapour			X	X	

4.2 Abbreviated terms

AGTU air generation and treatment unit

DOT device on test

5 Compressed air system

5.1 General

The breakdown of the compressed air system presented in this document is theoretical. However, it corresponds to constructive provisions commonly adopted on rail vehicles.

5.2 Breakdown of the system into functional units

The compressed air system of a rail vehicle is divided into functional units, as shown in [Figure 1](#).

The presence of each functional unit is determined by the type of vehicle.

NOTE The requirements in this document can also apply to external air supply systems used with rail vehicles.

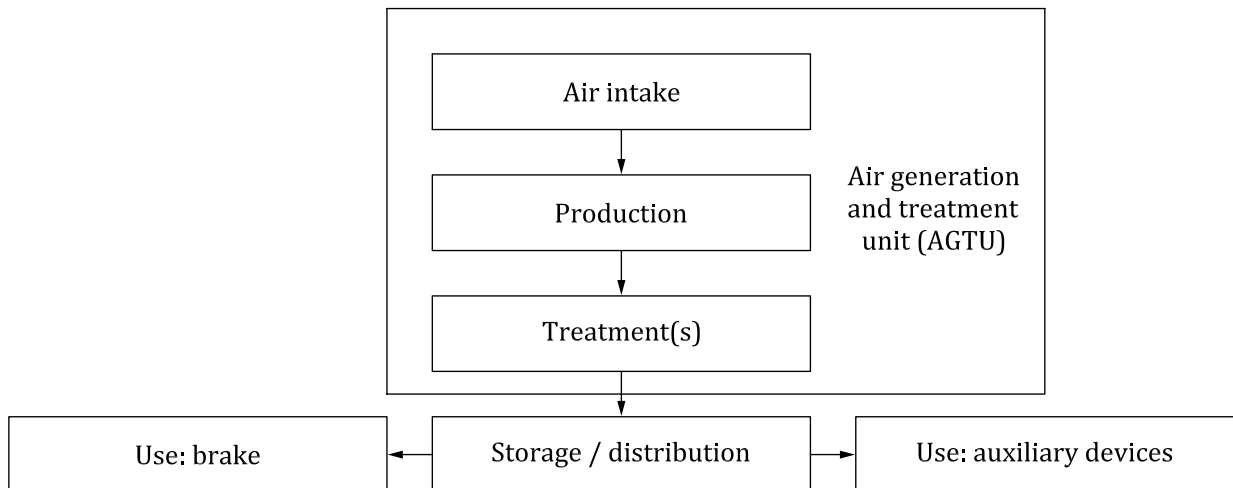

Figure 1 — Compressed air system functional units

6 Characteristics of the devices constituting the functional units

6.1 Air generation and treatment unit (AGTU)

6.1.1 Air intake

Air intake functional unit can include:

- intake filter: to prevent damage to the compressor by reducing atmospheric air contaminants.

6.1.2 Production of compressed air

Production of compressed air functional unit can include:

- compressors (e.g. piston, screw, vane);
- outlet filter(s).

6.1.3 Treatment of compressed air

Treatment of compressed air functional unit is used to achieve the air quality required for the reliability of pneumatic apparatus and systems of rail vehicles under predefined environmental conditions.

It can include the following:

- liquid separator and filter, to remove some contaminants coming from the compressor;
- air dryers, characterized by the dewpoint, to reduce the humidity level in the compressed air;
- outlet filter for retention of impurities coming from the air dryer.

6.2 Compressed air storage and distribution

Air system consisting of reservoirs and pipes for distribution and main reservoirs for air storage.

6.3 Use of compressed air for the brake

Brake system: assembly consisting of all the pneumatic equipment intended for braking the rail vehicle.

6.4 Use of compressed air for auxiliary devices

Auxiliary devices: assembly consisting of all the pneumatic equipment present on the rail vehicle except that used for ensuring braking.

7 Determination of the air quality classes

For determination of the air quality classes, a sample of the total compressed air flow at the outlet of the AGTU is used.

Measurements shall be made with an air intake temperature of the compressor of $20\text{ °C} \pm 5\text{ °C}$ (position 1 in [Figure 2](#)), except measurements to determine the classes of humidity for which air intake temperatures of the compressor are defined (see [Table 3](#)). When the AGTU is tested alone, then the cooling air (position 4 in [Figure 2](#)) and the air dryer ambient air (position 16 in [Figure 2](#)) shall be the same as the air at the compressor intake (position 1 in [Figure 2](#)). The AGTU outlet pressure (position 19 in [Figure 2](#)) shall be set at $9\text{ bar} \pm 0,5\text{ bar}$.

The mass concentration of water, oil and solid particles in compressed air varies due to sudden variations in the air flow rate, wear of the elements, and changes in flow rate, pressure, temperature and ambient conditions.

NOTE Liquid phase oil and water partially adhere to the walls and form a film or thin trails.

The air quality for particles shall be measured in accordance with the test methods defined in ISO 8573-4 (for classes 0 to 5 of [Table 2](#)).

The humidity (dewpoint) shall be measured in accordance with the test methods defined in ISO 8573-3 except the AGTU outlet pressure shall be $9\text{ bar} \pm 0,5\text{ bar}$ and temperature conditions defined in this document.

The air quality for oil shall be measured in accordance with the test methods defined in ISO 8573-2 and ISO 8573-5.

All measurements shall be done in a stabilized system in accordance with ISO 8573 (all parts). The results of the measured quality classes of a compressed air system are usually based on the average of a defined number of measurements made over a defined period of time during qualification.

The air quality is considered as degraded if one or more purity class is increased by one grade or more.

A demonstration should be performed to establish that the air quality is not degraded during the life of the AGTU.

If a demonstration is performed, it shall take into account:

- the operational condition (duty cycle, the regulation of pressure);
- the environmental condition (vibration, range of ambient temperature);
- the maintenance plan.

If a demonstration is not performed, a monitoring system shall be used to detect failures which can lead to a degradation of air quality.

Some options for demonstrating air quality are shown in [Annex B](#).

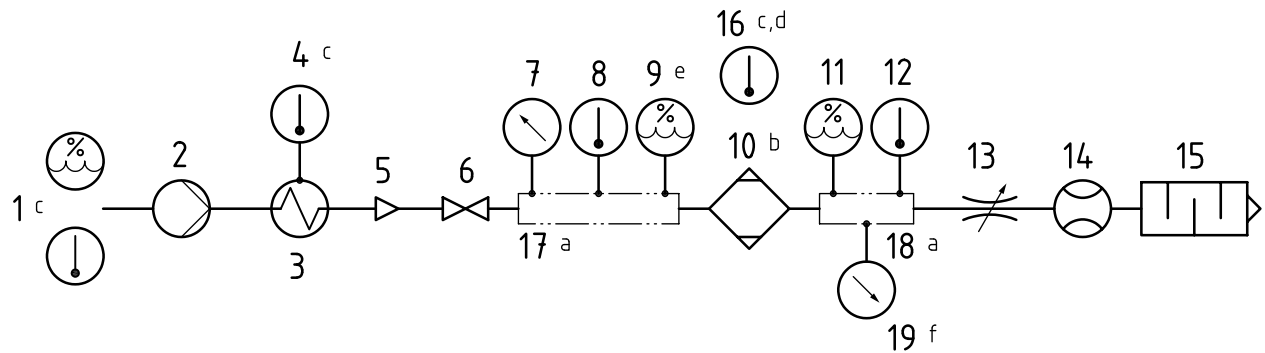

Key

- 1 air intake of compressor, air intake temperature, intake humidity (air temperature directly before the compressor air intake)
 - 2 compressor
 - 3 cooler
 - 4 cooling air, cooling air temperature
 - 5 check valve
 - 6 isolation cock
 - 7 air treatment inlet pressure
 - 8 air treatment inlet temperature
 - 9 air treatment inlet moisture content meter
 - 10 air treatment
 - 11 air treatment pressure dewpoint sensing/measuring, see ISO 8573-3 for different sampling techniques
 - 12 air treatment outlet temperature
 - 13 flow control valve
 - 14 flow meter
 - 15 silencer
 - 16 air treatment ambient temperature sensing/measuring
 - 17 air treatment inlet pressure measuring tube
 - 18 air treatment outlet pressure measuring tube
 - 19 AGTU outlet pressure
- a Details of a pressure measuring tubes are given in ISO 8573-1 and ISO 7183.
- b Air treatment can consist of air dryer and pre-/post-filtration units depending on the specific system layout.
- c Temperatures at compressor intake (1), cooling air (4) and air dryer ambient temperature (16) can be different depending on the specific application.
- d Air dryer ambient temperature shall not exceed the maximum permissible temperature of equipment.
- e Inlet moisture content to air dryer 100 %.
- f 9 bar (can be adapted to the system pressure of the rail vehicle).

Figure 2 — Example of AGTU test configuration

8 Air quality classes

8.1 Reference conditions

To normalize the test results, the following reference conditions shall be applied:

- temperature 20 °C;
- absolute air pressure 1 bar;

— relative water vapour pressure 0.

8.2 Characteristics of quality classes

The values characterizing the classes of the different contaminants are indicated in [Tables 2, 3](#) and [4](#).

It is possible to define the water air quality for extreme temperatures other than -40 °C (but lower than 0 °C) and/or than $+70\text{ °C}$ (but higher than $+40\text{ °C}$). The value of Δ to be fulfilled shall be defined by linear interpolation on the extreme temperature range. The air quality designation (see [8.3](#)) shall mention the extreme temperatures taken into account. An example is given in [Annex C](#) for temperature range -25 °C to $+50\text{ °C}$.

NOTE 1 The test with $T_0 = 70\text{ °C}$ represents a temporary operation in a specific condition (e.g. after a standstill without ventilation during hot ambient conditions) and does not represent a permanent operating condition.

The definition of the air quality shall be assessed on the test bench. The air quality can also be checked on the rail vehicle.

During the test on the test bench, the ambient temperature shall be the same as T_0 (position 1 in [Figure 2](#)).

In case the test is performed on a rail vehicle, the compressor air intake temperature and the ambient temperature can be different. The air intake temperature shall be in the range defined in [8.4](#).

The particle content of ambient air can have an influence on the results and the reproducibility of results of measurements for particle content at the outlet of the AGTU. During the test, special attention shall be paid to the cleanliness of the intake air of the AGTU. The particle content in the ambient air shall be declared.

NOTE 2 A common value of cleanliness of atmospheric air is described in EU Directive 2008/50/EC^[3].

Table 2 — Compressed air purity classes for particles

Class ^a	Maximum number of particles per cubic meter depending on the particle size d^b			
	$0,1\ \mu\text{m} < d \leq 0,5\ \mu\text{m}$	$0,5\ \mu\text{m} < d \leq 1,0\ \mu\text{m}$	$1,0\ \mu\text{m} < d \leq 5,0\ \mu\text{m}$	$5,0\ \mu\text{m} < d$
0	As defined in technical specification and more severe than class 1			
1	$\leq 20\ 000$	≤ 400	≤ 10	0^c
2	$\leq 400\ 000$	$\leq 6\ 000$	≤ 100	0^c
3	Not specified	$\leq 90\ 000$	$\leq 1\ 000$	0^c
4	Not specified	Not specified	$\leq 10\ 000$	0^c
5	Not specified	Not specified	$\leq 100\ 000$	0^c

^a To be compliant with a class, all the requirements of the number of particles depending on their size shall be fulfilled.

^b At reference conditions, see [8.1](#).

^c Due to pollution in testing equipment and due to the measurement technology, a tolerance of maximum five particles per cubic meter is acceptable.

Table 3 — Compressed air purity classes for humidity

Class^{ab}	Difference Δ between dewpoint under pressure ^c (position 11 in Figure 2) and air intake temperature of the compressor T_0 (see position 1 in Figure 2), K (dewpoint depression).				
	Relative humidity ≥ 95 % at the AGTU's inlet for $T_0 \leq 40$ °C. Relative humidity ≥ 85 % at the AGTU's inlet for $T_0 > 40$ °C.				
	$T_0 = -40$ °C ^b	$T_0 = 0$ °C ^b	$T_0 = 20$ °C ^b	$T_0 = 40$ °C ^b	$T_0 = 70$ °C ^b
1	$\Delta \leq -12,0$	$\Delta \leq -45,0$	$\Delta \leq -65,0$	$\Delta \leq -45,0$	$\Delta \leq -12,0$
2	$\Delta \leq -8,0$	$\Delta \leq -30,0$	$\Delta \leq -45,0$	$\Delta \leq -30,0$	$\Delta \leq -8,0$
3	$\Delta \leq -5,0$	$\Delta \leq -20,0$	$\Delta \leq -25,0$	$\Delta \leq -20,0$	$\Delta \leq -5,0$
4	$\Delta \leq -2,0$	$\Delta \leq -2,0$	$\Delta \leq -2,0$	$\Delta \leq -2,0$	$\Delta \leq -2,0$
5 ^d	$\Delta \leq +2,0$	$\Delta \leq +2,0$	$\Delta \leq +2,0$	$\Delta \leq +2,0$	$\Delta \leq +2,0$
6 ^d	$\Delta \leq +5,0$	$\Delta \leq +5,0$	$\Delta \leq +5,0$	$\Delta \leq +5,0$	$\Delta \leq +5,0$
^a To be compliant with a class, the value of Δ shall be compliant for each T_0 of the table. ^b The T_0 shall be respected with ± 2 K and Δ is defined with the measured T_0 . ^c Dewpoint under pressure is defined for a pressure of 9 bar in position 19 in Figure 2 . ^d Class usually not foreseen for new railway design.					

Table 4 — Compressed air purity classes for total oil concentration

Class	Mass concentration
	mg/m ^{3a}
0	As defined in technical specification and more severe than class 1
1	$\leq 0,01$
2	$\leq 0,1$
3	≤ 1
4	≤ 5
X	> 5
^a At reference conditions, see 8.1 .	

8.3 Designation of the compressed air purity

At any given point in the system definition, the designation of the compressed air purity shall contain the following information, in the following order:

- 1) “compressed air purity (ISO 4975)”;
- 2) purity class for particles;
- 3) purity class for humidity;
- 4) purity class for total oil concentration;
- 5) [air intake temperature range].

If the class of a particular contaminant 2, 3 or 4 is not specified, the number designating the class shall be replaced by a dash.

EXAMPLE

- compressed air purity (ISO 4975) 4 - 4 - — [-25 °C ; 70 °C];
- compressed air purity (ISO 4975) 5 - 3 - 4 [-30 °C ; 60 °C].

NOTE In Europe, the air intake of the compressor temperature range is defined as class of temperature in EN 50125-1.

8.4 Application to the pneumatic system of a rail vehicle

Except for specific applications (e.g. closed networks), the compressed air purity produced by the AGTU shall be “compressed air purity (ISO 4975) 3 - 3 - 4 [-25 °C ; 50 °C]” or better.

Annex A **(informative)**

Contaminants

A.1 General

The three main contaminants (particles, water, oil) have a mutual influence (e.g. dust agglomerates into coarse particles in the presence of oil or water, oil and water emulsify). They also sometimes become deposited or condensed (oil or water vapour) in the piping system, hence the phenomena of coalescence and agglomerate formation.

A.2 Particles

Dust (solid particles) ingresses into the compressor and the piping system.

- Compressor: The average particle size tends to increase with the concentration of dust in the atmosphere.
- Piping: When handling the pipes, all openings should be plugged to prevent the ingress of foreign bodies. The pipes should be cleaned and sealed in accordance with a process approved by the customer.

A.3 Water

Atmospheric air always contains water vapour. When this air is compressed, the partial pressure of water vapour increases, but there is no condensation of water due to the simultaneous increase in temperature caused by the compression. When the air is then cooled (e.g. in the intermediate or final cooler) in the distribution system or during expansion in a device, the water can condense into droplets, but the air remains saturated with water vapour. This moisture can cause corrosion, icing, etc.

A.4 Oil (mineral, synthetic or semi-synthetic)

In compressors with lubricated compression chambers, air inevitably collects oil. Air from non-lubricated (dry) compressors can also contain traces of oil that can be taken in with the atmospheric air.

Oil in compressed air can come in three different forms:

- liquid;
- aerosol;
- vapour.

Annex B (informative)

Demonstration of air quality during life cycle

B.1 General

Demonstration of air quality during the life cycle should be performed for the three types of contaminant. Each contaminant can be managed with a dedicated demonstration.

The degradation of air quality is described in [Clause 7](#).

B.2 Demonstration based on return of experience

Demonstration can use measurements of air quality on a comparable AGTU or air treatment units with similar working principle and comparable conditions (operational and environmental conditions representative for the specific application). The air quality measurement in accordance with this document should be performed just before the regular air quality assessment scheduled during regular maintenance of an AGTU using a similar compressor technology, air flow and maintenance plan. Measurements according to this document can be taken on the vehicle or in laboratory tests on AGTU or air treatment unit level, whatever is feasible.

The assessment of the air quality is done on the test bench. The air quality can also be checked on the rail vehicle.

For testing of air dryers in laboratory, ISO 7183 can be considered.

B.3 Demonstration based on AGTU tests

During air quality testing, the air treatment systems are typically tested under stationary working conditions regarding pressures, temperature and continuous air flow. Those conditions are simplified and represent nominal service conditions considered for the basic layout but do not reflect variable boundary conditions typical for true service on rail vehicles.

Target is to demonstrate the robustness of the AGTU system to show its capability to recover from temporary overload.

The demonstration can be performed during the type test of the device on test (DOT).

The following steps should be performed:

- a) measurement of air quality on the new DOT in defined conditions at an ambient temperature of $20\text{ °C} \pm 2\text{ °C}$ with continuous air flow until a stable dewpoint is reached;
- b) degrade the humidity level of process air to 0 K dewpoint depression referring to ambient air (position 11 in [Figure 2](#)) in a controlled way by (for example) blocking regeneration and continuous air flow;
- c) recover under conditions defined of ambient temperature of $20\text{ °C} \pm 2\text{ °C}$ until a stable dewpoint is reached;
- d) check if the DOT has recovered to starting status +1 in classes for oil and particles; the dewpoint depression should not increase by more than 20 K compared to the value defined in a).

NOTE The DOT can be the AGTU or the air treatment functional unit.

For testing of air dryers in laboratory, ISO 7183 can be considered.

B.4 Demonstration based on AGTU system analysis

If the system is equipped with some relevant treatment devices downstream from the air dryer (e.g. post-filter for solid contaminants, see position 10 in [Figure 2](#)), then the demonstration can be considered as successful.

A treatment device is considered as relevant when its filtration characteristics are in accordance with the required class of the particle.

Annex C (informative)

Example for temperature range

An example for temperature range -25 °C to 50 °C is given in [Table C.1](#).

Column $T_0 = -25\text{ °C}$ replaces column $T_0 = -40\text{ °C}$ and column $T_0 = 50\text{ °C}$ replaces column $T_0 = 70\text{ °C}$ in [Table 3](#).

Table C.1 — Temperature range

Class	Difference Δ between dewpoint under pressure (position 11 in Figure 2) and air intake temperature of the compressor T_0 (see position 1 in Figure 2), K (dewpoint depression). Relative humidity $\geq 95\%$ at the AGTU's inlet for $T_0 \leq 40\text{ °C}$. Relative humidity $\geq 85\%$ at the AGTU's inlet for $T_0 > 40\text{ °C}$.	
	$T_0 = -25\text{ °C}$	$T_0 = 50\text{ °C}$
1	$\Delta \leq -24,0$	$\Delta \leq -34,0$
2	$\Delta \leq -16,0$	$\Delta \leq -23,0$
3	$\Delta \leq -11,0$	$\Delta \leq -15,0$
4	$\Delta \leq -2,0$	$\Delta \leq -2,0$
5	$\Delta \leq +2,0$	$\Delta \leq +2,0$
6	$\Delta \leq +5,0$	$\Delta \leq +5,0$

Bibliography

- [1] ISO 7183, *Compressed-air dryers — Specifications and testing*
- [2] EN 50125-1, *Railway applications — Environmental conditions for equipment — Part 1: Rolling stock and on-board equipment*
- [3] Directive 2008/50/EC of the European Parliament and of the Council of 21 May 2008 on ambient air quality and cleaner air for Europe. OJ L 152, 11.6.2008, p. 1–44. Current consolidated version: 18/09/2015

