



BSI Standards Publication

<http://www.china-gauges.com/>

## Electrically powered wheelchairs, scooters and their chargers — Requirements and test methods

---

## National foreword

This British Standard is the UK implementation of [EN 12184:2022](#), which supersedes [BS EN 12184:2014](#), which is withdrawn.

The UK participation in its preparation was entrusted to Technical Committee CH/173, Assistive products for persons with disability.

A list of organizations represented on this committee can be obtained on request to its committee manager.

### Contractual and legal considerations

This publication has been prepared in good faith, however no representation, warranty, assurance or undertaking (express or implied) is or will be made, and no responsibility or liability is or will be accepted by BSI in relation to the adequacy, accuracy, completeness or reasonableness of this publication. All and any such responsibility and liability is expressly disclaimed to the full extent permitted by the law.

This publication is provided as is, and is to be used at the recipient's own risk.

The recipient is advised to consider seeking professional guidance with respect to its use of this publication.

This publication is not intended to constitute a contract. Users are responsible for its correct application.

© The British Standards Institution 2022  
Published by BSI Standards Limited 2022

ISBN 978 0 539 06649 4

ICS 11.180.10

**Compliance with a British Standard cannot confer immunity from legal obligations.**

This British Standard was published under the authority of the Standards Policy and Strategy Committee on 30 September 2022.

### Amendments/corrigenda issued since publication

Date	Text affected
------	---------------

---

EUROPEAN STANDARD

EN 12184

NORME EUROPÉENNE

EUROPÄISCHE NORM

September 2022

ICS 11.180.10

Supersedes EN 12184:2014

English Version

## Electrically powered wheelchairs, scooters and their chargers - Requirements and test methods

Fauteuils roulants électriques, scooters et leurs  
chargeurs - Exigences et méthodes d'essai

Elektrorollstühle, Scooters und zugehörige  
Ladegeräte - Anforderungen und Prüfverfahren

This European Standard was approved by CEN on 17 July 2022.

CEN members are bound to comply with the CEN/CENELEC Internal Regulations which stipulate the conditions for giving this European Standard the status of a national standard without any alteration. Up-to-date lists and bibliographical references concerning such national standards may be obtained on application to the CEN-CENELEC Management Centre or to any CEN member.

This European Standard exists in three official versions (English, French, German). A version in any other language made by translation under the responsibility of a CEN member into its own language and notified to the CEN-CENELEC Management Centre has the same status as the official versions.

CEN members are the national standards bodies of Austria, Belgium, Bulgaria, Croatia, Cyprus, Czech Republic, Denmark, Estonia, Finland, France, Germany, Greece, Hungary, Iceland, Ireland, Italy, Latvia, Lithuania, Luxembourg, Malta, Netherlands, Norway, Poland, Portugal, Republic of North Macedonia, Romania, Serbia, Slovakia, Slovenia, Spain, Sweden, Switzerland, Türkiye and United Kingdom.



EUROPEAN COMMITTEE FOR STANDARDIZATION  
COMITÉ EUROPÉEN DE NORMALISATION  
EUROPÄISCHES KOMITEE FÜR NORMUNG

**CEN-CENELEC Management Centre: Rue de la Science 23, B-1040 Brussels**

# Contents

Page

European foreword	vi
Introduction	vii
<b>1 Scope</b>	<b>7</b>
<b>2 Normative references</b>	<b>7</b>
<b>3 Terms and definitions</b>	<b>9</b>
<b>4 Test apparatus</b>	<b>10</b>
<b>5 Type classes</b>	<b>11</b>
<b>6 General requirements</b>	<b>11</b>
6.1 Risk management	11
6.2 Intended performance and technical documentation	11
6.3 Clinical evaluation and investigation	12
6.4 Wheelchairs that can be dismantled	12
6.5 Single-use fasteners	12
6.6 Biocompatibility and toxicity	12
6.7 Contaminants and residues	12
6.7.1 General	12
6.7.2 Substances which can leak in intended use or in a fault condition	13
6.8 Infection and microbiological contamination	13
6.8.1 Cleaning and disinfection	13
6.8.2 Animal tissue	13
6.9 Overflow, spillage, leakage, and ingress of liquids	13
6.9.1 Overflow	13
6.9.2 Spillage	14
6.9.3 Leakage	14
6.9.4 Ingress of liquids	14
6.10 Safety of moving parts	15
6.10.1 Squeezing	15
6.10.2 Mechanical wear	15
6.10.3 Emergency stopping functions	15
6.11 Prevention of traps for parts of the human body	15
6.11.1 Holes and clearances	15
6.11.2 V-shaped openings	16
6.12 Folding and adjusting mechanisms	16
6.12.1 General	16
6.12.2 Locking mechanisms	16
6.12.3 Guards	16
6.13 Surfaces, corners, edges and protruding parts	17
6.14 Ergonomic principles	17
6.15 General modifications to normative references	17
6.16 Applicable provisions for specified types of wheelchair	17
6.17 Recommendations	17
<b>7 Preparation for testing</b>	<b>18</b>
7.1 General	18
7.2 Test dummy	18
7.3 Human test occupant	18
<b>8 Wheelchair performance</b>	<b>18</b>
8.1 Driving characteristics	18
8.1.1 General	18
8.1.2 Ability to climb rated slope	18
8.1.3 Ground unevenness	19
8.1.4 Maximum downhill speed	19

8.1.5	Dynamic stability.....	20
8.1.6	Obstacle climbing and descending.....	20
8.1.7	Static stability.....	20
8.1.8	Maximum speed.....	21
8.1.9	Distance range.....	21
8.2	Static, impact and fatigue strength.....	21
8.2.1	Requirements.....	21
8.2.2	Test method.....	21
8.3	Wheelchairs for use as seats in motor vehicles.....	22
8.4	Climatic performance.....	22
<b>9</b>	<b>Component properties.....</b>	<b>22</b>
9.1	Foot supports, lower leg support assemblies and arm supports.....	22
9.1.1	Requirements.....	22
9.1.2	Test methods.....	23
9.2	Component mass.....	24
9.3	Pneumatic tyres.....	24
9.4	Means for maintaining a sitting posture.....	24
9.5	Resistance to ignition.....	24
9.5.1	General.....	24
9.5.2	Test methods.....	24
9.5.3	Power and control systems.....	25
<b>10</b>	<b>Propulsion and braking systems.....</b>	<b>25</b>
10.1	Means for operating brakes.....	25
10.1.1	Requirement.....	25
10.1.2	Test method for determination of brake operating forces.....	26
10.2	Braking functions.....	26
10.2.1	Requirements.....	26
10.2.2	Test methods.....	27
10.3	Freewheel device.....	28
<b>11</b>	<b>Operations.....</b>	<b>29</b>
11.1	Operations intended to be carried out by the occupant and/or assistant.....	29
11.2	Controls intended for operation by the occupant.....	29
11.3	Controls intended for operation by an assistant.....	30
11.4	Assistant control unit, push handles and handgrips.....	30
11.4.1	Requirements.....	30
11.4.2	Test method.....	30
11.5	Operating forces.....	31
11.5.1	Requirements.....	31
11.5.2	Test method.....	31
11.6	Occupied seating adjustments.....	32
11.6.1	Requirements.....	32
11.6.2	Test method.....	32
<b>12</b>	<b>Electrical systems.....</b>	<b>32</b>
12.1	General requirements.....	32
12.2	Circuit protection.....	32
12.2.1	Requirement.....	32
12.2.2	Preparation.....	32
12.2.3	Test method.....	33
12.3	Battery chargers.....	33
12.3.1	General.....	33
12.3.2	Operation.....	33
12.3.3	Manual adjustment for battery type.....	33
12.4	Charging connector.....	34
12.5	Battery enclosures and containers.....	34
12.6	Emergency stop.....	34
12.7	Lighting.....	34

12.8	Switching off while driving.....	35
12.9	Software.....	35
12.10	Lithium cells and batteries.....	35
12.11	Remote control.....	35
<b>13</b>	<b>Information supplied by the manufacturer.....</b>	<b>36</b>
13.1	General.....	36
13.2	Pre-sale information.....	36
13.3	User information.....	36
13.4	Service information.....	38
13.5	Labelling.....	38
<b>14</b>	<b>Test report, tables and figures.....</b>	<b>38</b>
<b>Annex A</b>	<b>(informative) Recommendations for dimensions and manoeuvring space of electrically powered wheelchairs.....</b>	<b>48</b>
<b>Annex B</b>	<b>(informative) Recommended design features.....</b>	<b>50</b>
<b>Annex C</b>	<b>(informative) Recommendations for lighting and reflectors.....</b>	<b>54</b>
<b>Annex D</b>	<b>(informative) EN 12184 and rail interoperability.....</b>	<b>56</b>
<b>Annex E</b>	<b>(informative) Recommendations for safety in freewheel mode.....</b>	<b>57</b>
<b>Annex F</b>	<b>(informative) Hazardous substances.....</b>	<b>59</b>
<b>Annex G</b>	<b>(normative) Applicable provisions for particular types of wheelchair.....</b>	<b>64</b>
<b>Annex H</b>	<b>(informative) Technical changes from the previous edition of EN 12184.....</b>	<b>70</b>
<b>Bibliography</b>	.....	<b>72</b>

## European foreword

This document ([EN 12184:2022](#)) has been prepared by Technical Committee CEN/TC 293 “Assistive products and accessibility”, the secretariat of which is held by SIS.

This European Standard shall be given the status of a national standard, either by publication of an identical text or by endorsement, at the latest by March 2023, and conflicting national standards shall be withdrawn at the latest by May 2024.

Attention is drawn to the possibility that some of the elements of this document may be the subject of patent rights. CEN shall not be held responsible for identifying any or all such patent rights.

This document supersedes [EN 12184:2014](#).

[Annex H](#) provides details of the significant technical changes between this document and [EN 12184:2014](#).

Requirements and test methods for manual wheelchairs are specified in [EN 12183](#).

Any feedback and questions on this document should be directed to the users’ national standards body. A complete listing of these bodies can be found on the CEN website.

According to the CEN-CENELEC Internal Regulations, the national standards organisations of the following countries are bound to implement this European Standard: Austria, Belgium, Bulgaria, Croatia, Cyprus, Czech Republic, Denmark, Estonia, Finland, France, Germany, Greece, Hungary, Iceland, Ireland, Italy, Latvia, Lithuania, Luxembourg, Malta, Netherlands, Norway, Poland, Portugal, Republic of North Macedonia, Romania, Serbia, Slovakia, Slovenia, Spain, Sweden, Switzerland, Türkiye and the United Kingdom.

## Introduction

This is the fifth edition of this European Standard. The previous editions were published in 1999, 2006, 2009 and 2014.

Where this document does not apply to particular wheelchairs, contracting parties should consider whether appropriate parts of this document can be used. Manufacturers can also consider whether appropriate parts of this document can be used to assess the performance of their products against the general safety and performance requirements of Regulation (EU) 2017/745 [21] of 5 April 2017 on medical devices.

<http://www.china-gauges.com/>



## 1 Scope

This document specifies requirements and test methods for electrically powered wheelchairs, with a maximum speed not exceeding 20 km/h, intended to carry one person of mass not less than 25 kg and not greater than 300 kg, including

- electrically powered scooters with three or more wheels,
- manual wheelchairs with an add-on electrically powered drive system,
- handrim-activated power-assisted wheelchairs,
- electrically powered stand-up wheelchairs,
- wheelchairs with a pivot drive wheel (HD), and
- push-assist wheelchairs.

This document does not apply to balancing wheelchairs, custom-made electrically powered wheelchairs or electrically powered wheelchairs intended for use in sports.

This document also specifies requirements and test methods for manual wheelchairs with electrically powered ancillary equipment.

## 2 Normative references

The following documents are referred to in the text in such a way that some or all of their content constitutes requirements of this document. For dated references, only the edition cited applies. For undated references, the latest edition of the referenced document (including any amendments) applies.

[EN 614-1:2006+A1:2009](#), *Safety of machinery - Ergonomic design principles - Part 1: Terminology and general principles*

[EN 1021-2:2014](#), *Furniture - Assessment of the ignitability of upholstered furniture - Part 2: Ignition source match flame equivalent*

[EN 12183:2022](#), *Manual wheelchairs - Requirements and test methods*

[EN 15194:2017](#), *Cycles - Electrically power assisted cycles - EPAC Bicycles*

EN 60335-2-29:2004,<sup>1)</sup> *Household and similar electrical appliances - Safety - Part 2-29: Particular requirements for battery chargers (IEC 60335-2-29:2002)*

EN 60601-1:2006,<sup>2)</sup> *Medical electrical equipment - Part 1: General requirements for basic safety and essential performance (IEC 60601-1:2005)*

EN 62133-2:2017,<sup>3)</sup> *Secondary cells and batteries containing alkaline or other non-acid electrolytes - Safety requirements for portable sealed secondary cells, and for batteries made from them, for use in portable applications - Part 2: Lithium systems*

EN 62304:2006,<sup>4)</sup> *Medical device software - Software life-cycle processes (IEC 62304:2006)*

EN ISO 10993-1:2020, *Biological evaluation of medical devices - Part 1: Evaluation and testing within a risk management process (ISO 10993-1:2018, including corrected version 2018-10)*

---

1) EN 60335-2-29:2004 is amended by EN 60335-2-29:2004/A2:2010 and EN 60335-2-29:2004/A11:2018.

2) EN 60601-1:2006 is amended by EN 60601-1:2006/A2:2021, EN 60601-1:2006/A12:2014 and EN 60601-1:2006/A1:2013; and corrected by EN 60601-1:2006/corrigendum Mar. 2010.

3) EN 62133-2:2017 is amended by EN 62133-2:2017/A1:2021.

4) EN 62304:2006 is amended by EN 62304:2006/A1:2015.

EN ISO 14155:2020, *Clinical investigation of medical devices for human subjects - Good clinical practice (ISO 14155:2020)*

EN ISO 14971:2019,<sup>5)</sup> *Medical devices - Application of risk management to medical devices (ISO 14971:2019)*

EN ISO 20417:2021, *Medical devices - Information to be supplied by the manufacturer (ISO 20417:2021, Corrected version 2021-12)*

EN ISO 22442-1:2020, *Medical devices utilizing animal tissues and their derivatives - Part 1: Application of risk management (ISO 22442-1:2020)*

[ISO 7176-1:2014](#), *Wheelchairs — Part 1: Determination of static stability*

[ISO 7176-2:2017](#), *Wheelchairs — Part 2: Determination of dynamic stability of electrically powered wheelchairs*

[ISO 7176-3:2012](#), *Wheelchairs — Part 3: Determination of effectiveness of brakes*

[ISO 7176-4:2008](#), *Wheelchairs — Part 4: Energy consumption of electric wheelchairs and scooters for determination of theoretical distance range*

[ISO 7176-6:2018](#), *Wheelchairs — Part 6: Determination of maximum speed of electrically powered wheelchairs*

[ISO 7176-8:2014](#), *Wheelchairs — Part 8: Requirements and test methods for static, impact and fatigue strengths*

[ISO 7176-9:2009](#), *Wheelchairs — Part 9: Climatic tests for electric wheelchairs*

ISO 7176-10:2008, *Wheelchairs — Part 10: Determination of obstacle-climbing ability of electrically powered wheelchairs*

[ISO 7176-11:2012](#), *Wheelchairs — Part 11: Test dummies*

ISO 7176-13:1989, *Wheelchairs — Part 13: Determination of coefficient of friction of test surfaces*

[ISO 7176-14:2008](#), *Wheelchairs — Part 14: Power and control systems for electrically powered wheelchairs and scooters — Requirements and test methods*

ISO 7176-19:2008,<sup>6)</sup> *Wheelchairs — Part 19: Wheeled mobility devices for use as seats in motor vehicles*

[ISO 7176-21:2009](#), *Wheelchairs — Part 21: Requirements and test methods for electromagnetic compatibility of electrically powered wheelchairs and scooters, and battery chargers*

[ISO 7176-22:2014](#), *Wheelchairs — Part 22: Set-up procedures*

[ISO 7176-25:2013](#), *Wheelchairs — Part 25: Batteries and chargers for powered wheelchairs*

[ISO 7176-26:2007](#), *Wheelchairs — Part 26: Vocabulary*

ISO 8191-2:1988, *Furniture — Assessment of ignitability of upholstered furniture — Part 2: Ignition source: match-flame equivalent*

[ISO 16840-10:2021](#), *Wheelchair seating — Part 10: Resistance to ignition of postural support devices — Requirements and test method*

---

5) EN ISO 14971:2019 is amended by EN ISO 14971:2019/A11:2021.

6) ISO 7176-19:2008 is amended by ISO 7176-19:2008/AMD 1:2015.

### 3 Terms and definitions

For the purposes of this document, the terms and definitions given in [ISO 7176-26:2007](#), [ISO 7176-14:2008](#) and the following apply.

NOTE The definitions of wheelchair and electrically powered wheelchair in [ISO 7176-26:2007](#) are replaced by [3.5](#) below.

ISO and IEC maintain terminological databases for use in standardization at the following addresses:

- ISO Online browsing platform: available at <https://www.iso.org/obp>
- IEC Electropedia: available at <https://www.electropedia.org/>

#### 3.1

##### **freewheel device**

means for disengaging the parking brake and/or the drive of a wheelchair to allow it to be manoeuvred manually

#### 3.2

##### **loaded wheelchair**

wheelchair loaded with a test dummy or loaded with a human test occupant

NOTE Instructions for selecting and fitting a test dummy or a human test occupant are given in [Clause 7](#).

#### 3.3

##### **non-spillable battery**

battery from which the electrolyte cannot escape whatever its orientation

#### 3.4

##### **rated slope**

maximum slope specified by the manufacturer on which the wheelchair meets the requirements for dynamic stability, static stability, braking performance and slope climbing, traversing and descending

#### 3.5

##### **wheelchair**

##### **electrically powered wheelchair**

wheeled mobility device, intended to transport a seated occupant who has impaired mobility, that is propelled by one or more electric motors controlled by the occupant or by an assistant

Note 1 to entry: An electrically powered wheelchair can have electronic control of speed and electronic or manual control of direction.

Note 2 to entry: The definition includes scooters.

#### 3.6

##### **pre-sale information**

publicly available information provided by the manufacturer about the wheelchair

NOTE A specification sheet is part of the pre-sale information.

#### 3.7

##### **push-assist wheelchair**

wheelchair intended to be partly propelled, braked, and/or steered by the manual effort of an assistant

EXAMPLE Wheelchair propelled by an electric motor and steered by forces applied to the push handles.

#### 3.8

##### **pivot drive wheel unit**

integrated propulsion system comprising a pivot drive wheel, a battery and a controller

### 3.9

#### **custom-made electrically powered wheelchair**

electrically powered wheelchair designed and manufactured for use by a named individual occupant that is not an adaptation of a mass-produced design

## 4 Test apparatus

**4.1 Horizontal test plane**, of sufficient length that the wheelchair can reach its maximum speed and decelerate to a stop. The horizontal test plane shall be dry, free from ice, and free from loose material (such as gravel). The horizontal test plane shall include a test area consisting of a continuous, flat, rigid surface with a coefficient of friction as specified in ISO 7176-13:1989, inclined to the horizontal at less than  $0,5^\circ$ . The surface of the test area shall lie between two imaginary parallel planes 5 mm apart per 1 000 mm of extension in any direction and 50 mm apart per 6 000 mm of extension in any direction. The test area shall be of sufficient size to complete the specified manoeuvres, except for acceleration and deceleration, which may occur outside the test area when they do not affect the test results.

The requirements for the test area do not apply to the parts of the horizontal test plane outside it, but the properties of all parts of the horizontal test plane, including any transitions at the edges of the test area, shall be sufficiently similar that the test results are not affected.

**4.2 Inclined test plane**, of sufficient length that the wheelchair can reach its maximum speed and decelerate to a stop. The inclined test plane shall be dry, free from ice, and free from loose material (such as gravel). The inclined test plane shall include a test area consisting of a continuous, flat, rigid surface with a coefficient of friction as specified in ISO 7176-13:1989, inclined to the horizontal at the specified angle  $\pm 0,5^\circ$ . The surface of the test area shall lie between two imaginary parallel planes 5 mm apart per 1 000 mm of extension in any direction and 50 mm apart per 6 000 mm of extension in any direction. The test area shall be of sufficient size to complete the specified manoeuvres, except for acceleration and deceleration, which may occur outside the test area when they do not affect the test results.

The requirements for the test area do not apply to the parts of the inclined test plane outside it, but the properties and slope of all parts of the inclined test plane, including any transitions at the edges of the test area, shall be sufficiently similar that the test results are not affected.

See [Figure 6](#).

The inclined test plane may have a fixed or adjustable slope. Where the slope is fixed, it can be necessary to use more than one inclined test plane.

**4.3 Means to apply a force** between 25 N and 200 N with an accuracy of  $\pm 5\%$  and with a rate of application less than 5 N/s.

**4.4 Means to measure force** in increments of 1 N in the range 0 N to 200 N with an accuracy of  $\pm 5\%$ .

**4.5 Means to measure speed** between 0 km/h and 25 km/h to an accuracy of  $\pm 5\%$ .

**4.6 Means to measure distance** in the range 0 m to 5 m with an accuracy of  $\pm 1$  mm or  $\pm 2\%$ , whichever is the greater.

**4.7 Supplementary weights** to add to a human test occupant to achieve the maximum occupant mass specified by the manufacturer and to achieve a similar mass distribution to the dummy specified in [4.9](#).

**4.8 Test block** capable of supporting the loaded wheelchair under each of its wheels, with length and width  $200\text{ mm} \pm 10\text{ mm}$ , thickness given in [Table 3](#) 'ground unevenness' and corner radii greater than 2,0 mm. For the two large surfaces, the whole of each surface shall lie between two imaginary horizontal planes 1 mm apart. The coefficient of friction shall be as specified in ISO 7176-13:1989.

**4.9 Test dummy**, of appropriate mass, as specified in [ISO 7176-11:2012](#).

**4.10 Means to measure torque** in the range 0,5 Nm to 10 Nm with an accuracy of  $\pm 2\%$ .

**4.11 Means to measure angles** to an accuracy of  $\pm 0,1^\circ$ .

**4.12 Means to move a brake lever** smoothly for 60 000 cycles at a frequency of not more than 0,5 Hz.

**4.13 Means to measure elapsed time** in the range 0 s to 30 s with an accuracy of  $\pm 1$  s.

## 5 Type classes

Wheelchairs shall be classified in one or more of the following three classes, depending upon their intended use:

- Class A: wheelchairs intended for driving on flat horizontal surfaces and gentle slopes;
- Class B: wheelchairs intended for driving on moderately uneven surfaces and on moderate slopes, in addition to the intended use described for Class A;
- Class C: wheelchairs intended for driving on uneven terrain and on steeper slopes, in addition to the intended uses described for Classes A and B.

Requirements specific to each class are given in [Table 3](#).

NOTE 1 Scooters are included within the classes above.

NOTE 2 Some requirements and exceptions specific to Class A are given in the text.

## 6 General requirements

### 6.1 Risk management

A risk management process shall be performed in accordance with EN ISO 14971:2019<sup>7)</sup>. For conformity with this document, all elements of the risk management process specified in EN ISO 14971:2019<sup>8)</sup> shall be applied except:

- the planning for, and execution of, production and post-production monitoring (EN ISO 14971:2019<sup>9)</sup>, 4.1 fourth indent, 4.4 item g) and [Clause 10](#)); and
- periodic reviews of the suitability of the risk management process (EN ISO 14971:2019<sup>10)</sup>, [4.2](#) third paragraph).

### 6.2 Intended performance and technical documentation

- a) The wheelchair shall have sufficient strength and durability to sustain all loads expected during intended use. This shall be confirmed by using, where appropriate, references to relevant clinical and scientific literature, strength and/or durability calculations, appropriate test standards and their test results, in addition to the requirements given in this document.

---

7) EN ISO 14971:2019 is amended by EN ISO 14971:2019/A11:2021.

8) EN ISO 14971:2019 is amended by EN ISO 14971:2019/A11:2021.

9) EN ISO 14971:2019 is amended by EN ISO 14971:2019/A11:2021.

10) EN ISO 14971:2019 is amended by EN ISO 14971:2019/A11:2021.

- b) The intended performance of the wheelchair, including, where appropriate, strength, durability and tipping stability, shall be described in technical documentation which sets out its functional characteristics, its application(s) and conditions of use.
- c) The technical documentation shall include, where appropriate, references to relevant clinical and scientific literature, any strength and/or life calculations, appropriate test standards and their test results.

### 6.3 Clinical evaluation and investigation

A clinical evaluation shall be conducted for the wheelchair.

If, as part of the product conformity assessment, the clinical evaluation requires a clinical investigation, the clinical investigation shall conform to the requirements of EN ISO 14155:2020. A clinical evaluation shall always be conducted before performing a clinical investigation.

NOTE Guidance for clinical evaluation is given in MEDDEV 2.7/1 [22].

### 6.4 Wheelchairs that can be dismantled

If it is intended that the wheelchair can be dismantled for storage or transportation, it shall not be possible to reassemble the wheelchair in a manner that presents a hazard.

### 6.5 Single-use fasteners

If it is intended that the wheelchair can be dismantled for storage or transportation, the fasteners which are loosened or removed to allow this dismantling shall not be single-use fasteners.

EXAMPLE Single-use fasteners include wood screws and self-tapping screws.

### 6.6 Biocompatibility and toxicity

Materials which come into contact with the human body shall be evaluated for biocompatibility in accordance with EN ISO 10993-1:2020 as part of the risk management process (see 6.1).

The evaluation shall take into account the intended use, including, where appropriate, contact with the occupant, an assistant, those involved in care of the occupant, and those involved in transportation and storage of the wheelchair.

Wheelchairs shall be designed and manufactured to minimize the risks posed by substances leaking from them. Special attention shall be given to substances which are carcinogenic, mutagenic or toxic to reproduction and other substances of very high concern (SVHCs). The evaluation should follow the guidance given in Annex F.

NOTE See Annex F for additional guidance.

### 6.7 Contaminants and residues

#### 6.7.1 General

The requirements given in 6.7.2 apply to substances which are an integral part of the wheelchair or are necessary for its function, such as oil and grease. The requirements do not apply to body fluids which the wheelchair is intended to collect (e.g. as a stoma-care product).

## 6.7.2 Substances which can leak in intended use or in a fault condition

Where a substance can leak from the wheelchair in intended use or in a fault condition:

- a) the substance shall be assessed for biocompatibility in accordance with EN ISO 10993-1:2020 as part of the risk management process, and the assessment shall consider intended use, including, where appropriate, contact with the occupant, an assistant, those involved in care of the occupant, and those involved in transportation and storage of the wheelchair; or
- b) the wheelchair shall have means of protection that minimizes the possibility of the substance becoming a biological hazard.

NOTE Substances that can leak include lubricants and hydraulic fluids.

EXAMPLE A method of protection from a hazardous substance is to place batteries in a container made from acid resistant material.

## 6.8 Infection and microbiological contamination

### 6.8.1 Cleaning and disinfection

If any parts of the wheelchair are intended to be cleaned, the method and suitable materials for cleaning shall be described in the instructions for use.

If any parts of the wheelchair are intended to be disinfected, the method and suitable materials for disinfection shall be described in the instructions for use.

NOTE For guidance, see [B.2.7](#).

If any parts of the wheelchair are intended to be cleaned by automatic washing systems or hand-held jet stream or steam washing, the details of the procedure, such as temperature, pressure, flow and pH value of cleaning/rinsing solution, shall be described in the instructions for use. Where practicable, the wheelchair shall be labelled with appropriate symbols to represent the method of cleaning.

### 6.8.2 Animal tissue

Where the wheelchair has been manufactured utilizing tissues of animal origin or their derivatives, the process specified in EN ISO 22442-1:2020 shall be followed as part of the risk management process (see [6.1](#)).

NOTE For guidance, see [B.2.13](#).

## 6.9 Overflow, spillage, leakage, and ingress of liquids

### 6.9.1 Overflow

#### 6.9.1.1 Requirements

If the wheelchair incorporates a reservoir or liquid storage chamber that can be overfilled or can overflow in intended use, liquid overflowing from the reservoir or chamber shall not wet electrical insulation or live parts which are liable to be adversely affected by such a liquid, nor shall a hazard be created. Unless indicated by a marking or by the instructions for use, no hazard shall be created if the wheelchair is tilted through an angle 15° greater than the maximum inclination that can occur during intended use.

### 6.9.1.2 Test method

Fill the reservoir to the maximum level specified by the manufacturer and, if possible, add further liquid equal to  $15^{+1}_0$  % of the capacity of the reservoir or until the reservoir is full, whichever is the lesser quantity.

Tilt the wheelchair through an angle of  $(a + 15)^{+1}_0$  ° to the horizontal in each direction, where  $a$  is the rated slope specified by the manufacturer (see 8.1.1). If necessary, refill the reservoir between tests.

Inspect the wheelchair, including any electrical insulation and any uninsulated live parts, to determine whether the requirements have been met. For electrical insulation, in case of doubt, subject the wheelchair to the dielectric strength test specified in EN 60601-1:2006 <sup>11)</sup>.

## 6.9.2 Spillage

### 6.9.2.1 Requirements

Wheelchairs requiring the handling of liquids in intended use shall be so constructed that spillage does not wet parts that creates a hazard.

### 6.9.2.2 Test method

Position the wheelchair on the horizontal test plane. Pour  $200^{+5}_0$  ml water steadily on an arbitrary point on the seat.

After the test, the wheelchair shall function as specified by the manufacturer.

## 6.9.3 Leakage

Wheelchairs shall be so constructed that liquid which can escape in single fault condition does not create a hazard.

## 6.9.4 Ingress of liquids

### 6.9.4.1 Requirements

If liquid can enter an enclosure unintentionally, either there shall be a means for the liquid to escape from the enclosure, or the liquid shall not create a hazard.

NOTE 1 See [B.2.14](#).

NOTE 2 [ISO 7176-9:2009](#) also covers ingress of liquids into enclosures. See [8.4](#).

### 6.9.4.2 Test method

Test whether the liquid can escape from an enclosure by adding liquid and then tilting the wheelchair 10° in each direction. If any liquid remains in the enclosure, test the wheelchair to determine whether it is still functional, and determine whether the liquid can create a hazard.

---

11) EN 60601-1:2006 is amended by EN 60601-1:2006/A2:2021, EN 60601-1:2006/A12:2014 and EN 60601-1:2006/A1:2013; and corrected by EN 60601-1:2006/corrigendum Mar. 2010.



## 6.10 Safety of moving parts

### 6.10.1 Squeezing

Unless the intended purpose of part of the wheelchair is to grip, cut, squeeze or provide a similar function, or if the intended use cannot be achieved without a risk of squeezing:

- a) any moving parts that constitute a hazard shall be provided with guards that cannot be removed without the use of a tool; or
- b) the gap between exposed parts of the wheelchair that move relative to each other shall be maintained throughout the range of movement at less than the relevant minimum value or more than the relevant maximum value specified in [Table 1](#); or
- c) if cords (ropes), chains or drive belts are used, either they shall be confined so that they cannot run off or jump out of their guiding devices, or a hazardous situation shall be prevented by other means; mechanical means used for this purpose shall not be removable without the use of a tool; or
- d) the wheelchair shall incorporate a control device which enables the movement when it is operated and stops the movement when it is released (e.g. a spring-loaded device that returns to the stop position when released); or
- e) the wheelchair shall incorporate means to detect that a person is in danger of being trapped and to prevent injury automatically (e.g. by stopping the movement).

For moving parts that can cause squeezing, manufacturers shall take into consideration the part or parts of the body that are at risk. It is necessary to specify the characteristics of the persons involved in the intended use, so that the appropriate safe distances can be applied.

**Table 1 — Safe distances between moving parts**

To avoid	Safe distances for adults	Safe distances for children
Finger traps	Less than 8 mm or more than 25 mm	Less than 4 mm or more than 25 mm
Foot traps	Less than 35 mm or more than 120 mm	Less than 25 mm or more than 120 mm
Head traps	Less than 120 mm or more than 300 mm	Less than 60 mm or more than 300 mm
Genitalia traps	Less than 8 mm or more than 75 mm	Less than 8 mm or more than 75 mm

### 6.10.2 Mechanical wear

Parts subject to mechanical wear likely to create a hazard shall be accessible for inspection.

### 6.10.3 Emergency stopping functions

The requirements specified in [12.6](#) shall apply to moving parts of the body support system if there is a risk that the occupant can be squeezed or that a single fault can create a hazard.

## 6.11 Prevention of traps for parts of the human body

### 6.11.1 Holes and clearances

Holes in, and clearances between stationary parts that are accessible to the occupant and/or assistant during the intended use of the wheelchair shall be as specified in [Table 2](#).

If the intended purpose of the wheelchair cannot be met without a hazard caused by the size of holes and the clearance between stationary parts, a warning and instructions on how to control the risk shall be provided in the instructions for use.

For stationary parts that can cause a trap, manufacturers shall take into consideration the parts of the body that are at risk. It is necessary to specify the characteristics of the persons involved in the intended use, so that the appropriate safe distances can be applied.

The design of parts that confine a hole or clearance shall take into consideration the forces that can be applied in normal use.

NOTE Forces can cause holes or clearances to widen, which can lead to loss of conformity with the requirements of [Table 2](#).

The lower limits specified in [Table 2](#) do not apply for holes with the shape of a keyhole, or for V-shaped openings. When inspecting the wheelchair for traps for body parts any flexibility and/or elasticity of adjacent parts shall be taken into account.

### 6.11.2 V-shaped openings

The risk of entrapment in V-shaped openings shall be addressed by the risk management process (see [6.1](#)).

NOTE For guidance, see [B.2.15](#).

**Table 2 — Safe distances between stationary parts**

To avoid	Safe distances for adults	Safe distances for children
Finger traps	Less than 8 mm or more than 25 mm	Less than 5 mm or more than 12 mm
Foot traps	Less than 35 mm or more than 100 mm	Less than 25 mm or more than 45 mm
Head traps	Less than 120 mm or more than 250 mm	Less than 60 mm or more than 250 mm
Genitalia traps	Less than 8 mm or more than 75 mm	Less than 8 mm or more than 75 mm

## 6.12 Folding and adjusting mechanisms

### 6.12.1 General

Folding and adjusting mechanisms can present a hazard if parts of the body can enter a gap between parts and be trapped when the gap is closed.

If the wheelchair incorporates folding and/or adjusting mechanisms it shall conform to [6.12.2](#) and [6.12.3](#).

### 6.12.2 Locking mechanisms

Folding and adjusting mechanisms shall be capable of being securely locked when the wheelchair is in a working configuration. They shall also be capable of being securely locked when folded if they constitute a risk. The wheelchair shall fold in a safe manner.

### 6.12.3 Guards

Either:

- a) the wheelchair shall incorporate means to protect the occupant from trap and/or squeeze hazards; or

- b) the gap between exposed parts of the wheelchair that move relative to each other shall be maintained throughout the range of movement at less than the applicable minimum value or more than the applicable maximum value set out in [Table 1](#); or
- c) if the intended purpose of the wheelchair cannot be met without a hazard such as squeezing, a warning and instructions on how to control the risk shall be provided in the instructions for use.

The design of a guard shall take into consideration the forces that can be applied in normal use.

### 6.13 Surfaces, corners, edges and protruding parts

If not required for intended use, accessible edges, corners and surfaces of the wheelchair shall be smooth and be free from burrs and sharp edges.

If not required for intended use, wheelchairs shall not have protruding parts. Where practicable, protruding parts shall have protection to prevent injury and/or damage.

NOTE For guidance, see [A.2.16](#).

### 6.14 Ergonomic principles

Wheelchairs shall be designed in accordance with the ergonomic principles set out in [EN 614-1:2006+A1:2009](#), taking into account the specific needs of the intended occupant. The ergonomic principles set out in [EN 614-1:2006+A1:2009](#) also apply to an assistant, those involved in care of the wheelchair occupant, and those involved in transportation and storage of the wheelchair.

Grips, handles and foot supports shall suit the functional anatomy of the occupant and/or assistant, in accordance with the intended use, and meet the following requirements:

- a) the distance between any handle (part intended to be gripped) requiring an operating force of more than 10 N and any other part of the wheelchair shall not be less than 35 mm;
- b) the vertical distance between the upper surface of a foot support or pedal in its operating position and any other part of the wheelchair shall not be less than 75 mm;
- c) the diameter of any operating handle or knob requiring an operating force of more than 10 N shall be between 19 mm and 43 mm;
- d) the upper surface of any pedal intended for operation by an assistant shall not be more than 300 mm above the ground.

NOTE For guidance on operating forces, see [B.2.17](#).

### 6.15 General modifications to normative references

For the purposes of this document, the scope of this document supersedes any restrictions in scopes of the normative references listed in [Clause 2](#) concerning maximum speed and maximum occupant mass.

### 6.16 Applicable provisions for specified types of wheelchair

[Annex G](#) specifies the provisions in this document that apply to some specified types of wheelchair. Wheelchairs of types listed in [G.1](#) shall meet the applicable requirements of [Annex G](#).

### 6.17 Recommendations

The following annexes provide recommendations:

- [Annex A](#) for dimensions and manoeuvring space;
- [Annex B](#) for design features;

- [Annex C](#) for lighting and reflectors;
- [Annex E](#) for safety in freewheel mode.

## 7 Preparation for testing

### 7.1 General

Unless otherwise specified in [Clauses 8, 9, 10, 11](#) and [12](#), the wheelchair shall be prepared for testing as specified in [ISO 7176-22:2014](#) with the following modification.

If a test procedure requires the use of a test dummy or human test occupant, they shall be selected and fitted as specified in [7.2](#) or [7.3](#). This instruction supersedes instructions for loading the wheelchair in the referenced standards.

If, due to the speed of the wheelchair, the test plane specified in a referenced document is of insufficient size to conduct the specified tests, use the horizontal test plane specified in [4.1](#) or an inclined test plane specified in [4.2](#) as applicable.

### 7.2 Test dummy

Select a test dummy, as specified in [ISO 7176-11:2012](#), of mass equal to the maximum occupant mass specified by the wheelchair manufacturer, with a tolerance of 0 kg to +5 kg.

Fit the test dummy in the wheelchair as specified in [ISO 7176-22:2014](#).

### 7.3 Human test occupant

Select a human test occupant whose mass, in combination with any supplementary weights as specified in [4.7](#), is equal to the maximum occupant mass specified by the wheelchair manufacturer, with a tolerance of 0 kg to +5 kg.

Seat the occupant in the wheelchair and position and secure the supplementary weights to give substantially the same mass distribution as the test dummy when fitted as specified in [ISO 7176-22:2014](#).

**WARNING — - This testing is potentially hazardous to a human test occupant and other test personnel. Appropriate safety precautions should be taken to avoid injury.**

## 8 Wheelchair performance

### 8.1 Driving characteristics

#### 8.1.1 General

The loaded wheelchair shall meet the driving performance requirements specified in [Table 3](#) and [Table 4](#) for the type class of the wheelchair as specified in [Clause 5](#).

The rated slope specified by the manufacturer shall be not less than that specified in [Table 3](#) for the type class of the wheelchair.

#### 8.1.2 Ability to climb rated slope

##### 8.1.2.1 Requirements

The wheelchair shall be capable of climbing at a speed not less than 2 km/h:

- the applicable rated slope for the type class of wheelchair specified in [Table 3](#); or

- the rated slope specified by the manufacturer, if it is greater.

The wheelchair passes the test specified in [8.1.2.2](#) if it achieves or exceeds a speed of 2 km/h after travelling 5 m up the slope.

#### 8.1.2.2 Test method

Use an inclined test plane as specified in [4.2](#) and the means to measure speed specified in [4.5](#).

Starting on the inclined test plane, drive the loaded wheelchair up the slope using the maximum speed command.

When the wheelchair has travelled  $(5,0 \pm 0,1)$  m up the slope and is inside the test area, measure and record the speed to an accuracy of  $\pm 10\%$ .

#### 8.1.3 Ground unevenness

##### 8.1.3.1 Principle

It is important that a wheelchair is able to drive on uneven terrain without stopping even if one wheel is at a higher level than the others.

##### 8.1.3.2 Requirement

The wheelchair shall be capable of driving when any of its wheels is raised to a height specified in [Table 3](#) for ground unevenness.

##### 8.1.3.3 Test method

- Place the loaded wheelchair in the test area of the horizontal test plane ([4.1](#)).
- Place the test block specified in [4.8](#) under one wheel, such that one of its largest faces is flat on the test plane with the centre of the block beneath the point of contact with the wheel.
- Attempt to drive the loaded wheelchair off the test block.
- Record the result of the test.
- Repeat for the remaining wheels, one at a time.
- The test is passed if the wheelchair is able to drive off the test block for each wheel.

#### 8.1.4 Maximum downhill speed

##### 8.1.4.1 Requirement

The wheelchair shall not exceed 125 % of its maximum speed on the horizontal, when driving down

- the applicable rated slope for the type class of wheelchair specified in [Table 3](#); or
- the rated slope specified by the manufacturer, if it is greater.

##### 8.1.4.2 Test method

- Drive the loaded wheelchair at maximum speed down the inclined test plane ([4.2](#)) with the required slope.
- Measure the speed achieved, using the means specified in [4.5](#), when the wheelchair is inside the test area.

c) Record the measured speed and record whether the wheelchair has met the requirement.

### 8.1.5 Dynamic stability

#### 8.1.5.1 Requirements

The dynamic response score of the wheelchair shall be 2 or 3 as specified in Table C.10 of [ISO 7176-2:2017](#) when tested on

- the applicable rated slope for the type class of wheelchair specified in [Table 3](#); or
- the rated slope specified by the manufacturer, if it is greater.

#### 8.1.5.2 Test method

- a) Load the wheelchair with the test dummy in accordance with [7.2](#). Do not use a human test occupant.
- b) Test the loaded wheelchair in accordance with [ISO 7176-2:2017](#) with the following modifications:
  - 1) for tests on slopes the test plane is inclined relative to the horizontal as specified in [8.1.5.1](#);
  - 2) fixed test planes or adjustable test planes may be used;
  - 3) if the manufacturer recommends a technique for driving on a slope, test the wheelchair using only the recommended technique; if not, the test methods are unmodified;
  - 4) where the maximum occupant mass is greater than 100 kg, repeat the rearward dynamic stability tests with a 100 kg dummy fitted to the wheelchair.

### 8.1.6 Obstacle climbing and descending

#### 8.1.6.1 Requirements

The wheelchair shall be capable of climbing and descending obstacles of the height specified in [Table 3](#) for the type class of the wheelchair or the maximum obstacle height specified by the manufacturer, whichever is greater, without any part of the wheelchair other than wheels or a kerb climbing device contacting the obstacle or the test plane.

#### 8.1.6.2 Test method

Test the wheelchair as specified in ISO 7176-10:2008 for climbing and descending a test obstacle of the height specified in [Table 3](#) for the type class of the wheelchair or the maximum obstacle height specified by the manufacturer, whichever is greater.

If the manufacturer specifies a method for climbing and descending steps, kerbs or obstacles, test as specified in ISO 7176-10:2008 using only the manufacturer's method. If the manufacturer specifies a run-up distance greater than that specified in ISO 7176-10:2008, limit the run-up distance to the maximum specified in that document.

If the manufacturer of the wheelchair does not specify a method for climbing and descending steps, kerbs or obstacles, test as specified in ISO 7176-10:2008 using the methods specified in that document.

### 8.1.7 Static stability

#### 8.1.7.1 Requirements

The wheelchair shall meet or exceed the minimum requirements for static stability specified in [Table 3](#) for the type class of the wheelchair.

### 8.1.7.2 Test method

Test the loaded wheelchair in the least-stable configuration for each direction as specified in [ISO 7176-1:2014](#) to determine whether it meets or exceeds the angles in [Table 3](#) for the type class of the wheelchair.

Where the maximum occupant mass is greater than 100 kg, repeat the rearward static stability test with a 100 kg dummy fitted to the wheelchair.

### 8.1.8 Maximum speed

#### 8.1.8.1 Requirements

The maximum speed of the wheelchair when travelling forwards and travelling in reverse on the horizontal shall not exceed the maximum speed requirements specified in [Table 3](#) for the type class of the wheelchair.

#### 8.1.8.2 Test method

Test the loaded wheelchair as specified in [ISO 7176-6:2018](#) for the maximum forward speed and maximum reverse speed on a horizontal surface.

Record the results and determine whether the requirement has been met.

### 8.1.9 Distance range

#### 8.1.9.1 Requirements

The theoretical continuous driving distance range for the wheelchair shall not be less than the requirement specified in [Table 3](#) for the type class of the wheelchair.

#### 8.1.9.2 Test method

Load the wheelchair as specified in [ISO 7176-4:2008](#), except that the mass of the load shall be the maximum occupant mass or 100 kg, whichever is the lower.

Test the loaded wheelchair as specified in [ISO 7176-4:2008](#).

Record the results and determine whether the requirement has been met.

It is recognized the use of shorter test tracks in the range specified by [ISO 7176-4:2008](#) can give smaller values of theoretical distance range. Use of the largest specified track length should be treated as the referee method.

## 8.2 Static, impact and fatigue strength

### 8.2.1 Requirements

The wheelchair shall conform to the requirements of [ISO 7176-8:2014](#) with the exception that wheelchairs of Class A are not required to be tested as specified in [ISO 7176-8:2014](#), 10.4, drop test.

Arm supports shall conform to the static loading requirements of [ISO 7176-8:2014](#) in the least favourable intended operating position.

NOTE [ISO 16840-3](#) provides related test methods for postural support devices.

### 8.2.2 Test method

Test the wheelchair in accordance with [ISO 7176-8:2014](#) with modifications as specified in [8.2.1](#).

### 8.3 Wheelchairs for use as seats in motor vehicles

If the manufacturer specifies that the intended use of the wheelchair includes use as a seat in a motor vehicle, the wheelchair shall conform to the requirements of ISO 7176-19:2008<sup>12)</sup>, with the following modifications to subclauses of ISO 7176-19:2008<sup>13)</sup>.

*4.1.2 is replaced by the following:*

If a wheelchair is intended by the manufacturer to also be secured by a docking securement device in public transportation and/or different private vehicles, the securement points on the wheelchair and/or of the wheelchair tiedown adaptors shall conform to the performance requirements in [Clause 5](#).

*5.1, second paragraph, is replaced by the following:*

All webbing of wheelchair-anchored belt restraints shall have a burning rate not exceeding 100 mm/min when tested as specified in [ISO 3795](#).

*5.2.1 a) is replaced by the following:*

If the wheelchair has a head restraint, the horizontal excursions of the ATD and the wheelchair, with respect to the impact sled, shall not exceed the limits in Table 7 at any time during the test.

If the wheelchair does not have a head restraint, the horizontal excursions of the ATD and the wheelchair with respect to the impact sled shall not exceed the limits in Table 7 at any time during the test, with the exception that the limits specified in Table 7 for excursion of the back of the head of the ATD,  $X_{\text{head, R}}$ , do not apply.

*5.2.2 e) is replaced by the following:*

Primary occupant-load-carrying components of the wheelchair shall not show visible signs of failure, unless there is a backup system to provide support.

If the wheelchair does not have a head restraint, risks associated with head excursion and neck forces to which the occupant can be exposed during vehicle collisions shall be addressed in the risk management process (see [6.1](#)).

### 8.4 Climatic performance

The wheelchair shall conform to the requirements of [ISO 7176-9:2009](#).

[ISO 7176-9:2009](#) includes testing for resistance to ingress of liquid, which is also required by [ISO 7176-14:2008](#), 13.1. It is not necessary to duplicate the test.

## 9 Component properties

### 9.1 Foot supports, lower leg support assemblies and arm supports

#### 9.1.1 Requirements

The wheelchair shall be fitted with foot supports that have a means of positioning the occupant's feet at the required height and prevent the occupant's feet from sliding backwards.

Any swing away, movable or removable foot support, lower leg support assembly or arm support fitted on the wheelchair shall:

- a) incorporate a means to locate it securely in any intended operating position;

---

12) ISO 7176-19:2008 is amended by ISO 7176-19:2008/AMD 1:2015.

13) ISO 7176-19:2008 is amended by ISO 7176-19:2008/AMD 1:2015.



- b) be adjustable in increments not exceeding 25 mm in any direction;
- c) be accessible and operable by the occupant or an assistant or both in accordance with the manufacturer's intended use of the wheelchair;
- d) be within the reach space shown in [Figure 1](#); and
- e) be operable without the use of a tool.

NOTE The ability to make adjustments without the use of a tool is not required.

Where the wheelchair has separate foot supports which have a gap between them or the possibility of a gap being formed when they are loaded:

- f) means to prevent the occupant's feet from sliding into the gap shall be provided; or
- g) when the foot supports are tested in accordance with [9.1.2.2](#), any gap between them shall be less than:
  - 25 mm if the wheelchair is intended for use by a child;
  - 35 mm if the wheelchair is not intended for use by a child.

## 9.1.2 Test methods

### 9.1.2.1 General performance

Fit foot supports, lower leg support assemblies and arm supports in the operating position(s) specified in the manufacturer's instructions.

Adjust the foot supports, lower leg support assemblies and arm supports as specified in the manufacturer's instructions.

Record whether the foot supports, lower leg support assemblies and arm supports have met the requirements.

### 9.1.2.2 Foot support gap

Simultaneously apply a force  $F_0^{+5}$  N to the centroid of each foot support, normal to the plane of the unloaded foot support. In cases where the foot support has no identifiable plane, apply the force within 5° of vertical. The force  $F$  is calculated from the following equation:

$$F = 0,125 \times m \times g$$

where

- $F$  is the force applied to each foot support, expressed in newtons;
- $m$  is the maximum occupant mass specified by the manufacturer, expressed in kilograms;
- $g$  is the acceleration due to gravity, 9,81 m/s<sup>2</sup>.

NOTE An eighth of the maximum occupant weight represents a typical load for measuring the gap.

Apply the force for 5 s to 10 s.

While the force is being applied measure the largest distance between the foot supports, as follows:

- 1) identify the surfaces of the foot supports that enclose the gap between the foot supports;

- 2) from each point on the surface of one foot support, measure the distance to the nearest point on the surface of the opposite foot support;
- 3) record the largest distance measured to an accuracy of  $\pm 1$  mm.

Record whether the foot supports have met the requirements.

## 9.2 Component mass

If the wheelchair is intended to be dismantled for storage or transportation, any component that requires moving or handling and that has a mass greater than 10 kg shall be provided with suitable handling devices (e.g. handles). The manufacturer shall provide information indicating the points where such components can be lifted and describing how they shall be handled during disassembly, lifting, carrying, and assembly to reduce risks to the person or persons moving or handling them.

## 9.3 Pneumatic tyres

All pneumatic tyres on the wheelchair shall have the same type of valve connection. Valves should be readily accessible when using the intended inflating tool.

The tyres or the rims shall be marked with the maximum pressure in kPa, bar or PSI.

## 9.4 Means for maintaining a sitting posture

The wheelchair shall have provision for a means to be fitted that enables the occupant to maintain a sitting posture.

EXAMPLE Anterior pelvic support, pelvic positioning support.

NOTE The term 'support' is used for means to sustain occupant posture, and the term 'restraint' is used for means to limit movement of motor vehicle occupants in the event of collision.

If the risk management process (6.1) indicates a risk of the occupant tipping or sliding forwards when the wheelchair is decelerating, the means shall be provided with the wheelchair; otherwise the manufacturer of the wheelchair shall make available such means as an option.

## 9.5 Resistance to ignition

### 9.5.1 General

The surfaces of components which support the occupant, or which stay in contact with the occupant or the occupant's clothing, shall be tested as specified in 9.5.2. Progressive smouldering ignition or flaming ignition as defined in the standard applied shall not occur.

This requirement does not apply to components of the power and control system, which are covered by 9.5.3.

It is not necessary to test components that are inherently resistant to ignition, e.g. steel frame tube.

NOTE ISO 7176-19 provides related requirements for belt-type restraints. See 8.3.

### 9.5.2 Test methods

#### 9.5.2.1 Selection of test method

The test method specified in 9.5.2.2 is the preferred test method. It is the referee test method, which is used to resolve doubts or dispute.

The test methods specified in 9.5.2.3 may be used as alternatives.

### 9.5.2.2 Referee test method

Select and test a sample of the component as specified in [ISO 16840-10:2021](#).

NOTE The introduction to [ISO 16840-10:2021](#) provides a rationale for use of the test method.

### 9.5.2.3 Alternative test methods

Test the material of each component in accordance with [EN 1021-2:2012](#) or [ISO 8191-2:1988](#).

### 9.5.3 Power and control systems

Either of the following options a) or b) shall apply.

- a) The manufacturer shall adopt appropriate means to eliminate or reduce as far as reasonably practicable the risk of a hazardous situation developing from the ignition of any part of the power and control system of the wheelchair. The manufacturer shall apply the risk management process (see [6.1](#)) to manage that risk.
- b) The power and control system of the wheelchair shall meet the requirements of [ISO 7176-14:2008](#), 9.7, resistance to ignition.

## 10 Propulsion and braking systems

### 10.1 Means for operating brakes

#### 10.1.1 Requirement

- a) Means for operating brakes shall:
  - 1) be accessible and operable by the occupant or an assistant or both in accordance with the manufacturer's intended use of the wheelchair;
  - 2) be within the reach space shown in [Figure 1](#), if the wheelchair is intended to be operated by the occupant;
  - 3) be within the reach space shown in [Figure 2](#), if the wheelchair is intended to be operated solely by an assistant;
  - 4) have operating forces for engaging and disengaging that do not exceed those stated in [Table 3](#) when tested in accordance with [10.1.2](#).

NOTE The brake lever type shown in [Figure 3](#) has a whole hand operation.

- b) If one or more brake levers are fitted to a wheelchair in the form used on bicycles and mopeds:
  - 1) for wheelchairs with a maximum occupant mass not greater than 150 kg, the force applied to each lever to hold the loaded wheelchair stationary on the rated slope shall not exceed 60 N;
  - 2) for wheelchairs with a maximum occupant mass greater than 150 kg, the force applied to each lever to hold the loaded wheelchair stationary on the rated slope should not exceed 60 N;
  - 3) the grip width of such brake levers when no force is applied, measured 15 mm from the end of the brake lever, shall not be greater than 100 mm and should not be greater than 80 mm (see [Figure 3](#)).
- c) Means for releasing parking brakes shall be protected against activation caused by accidental contact.

EXAMPLE A suitable shape and location for the means for disengagement.

### 10.1.2 Test method for determination of brake operating forces

- a) Adjust the brakes as specified by the manufacturer.
- b) Select the part of the lever through which the force is to be applied as shown in [Figure 4](#).
  - 1) If the lever is fitted with a generally spherical knob, apply the force through the centre of the knob.
  - 2) If the lever is tapered, apply the force through the point where the largest cross section intersects the centre line of the lever.
  - 3) If the lever is parallel or any shape other than those above, apply the force through a point on the centre line of the lever 15 mm from the end.
  - 4) If the form of the lever is such that the lever is gripped by the whole hand apply the force through the centre line of the lever 15 mm from the end.
  - 5) If the brake is operated by pushing or pulling a bar or pad, apply the force to the centroid of the bar or pad.
- c) Apply the brakes while measuring the force with the device specified in [4.4](#) aligned in the direction of travel of the point of application of the force in order to measure the maximum application force required.
- d) Release the brakes while measuring the force with the device specified in [4.4](#) aligned in the direction of travel of the point of application of the force in order to measure the maximum releasing force required.
- e) Perform c) and d) three times in total and record the measurements.
- f) Calculate and record the arithmetic mean value of the application and the release forces measured separately.
- g) Determine whether or not the requirements for operating forces stated in [Table 3](#) have been met.

## 10.2 Braking functions

### 10.2.1 Requirements

- a) The wheelchair shall have a running brake which operates independently of tyre wear and tyre inflation pressure and which does not exceed the maximum stopping distance specified in [Table 4](#) when tested in accordance with [10.2.2.1](#).

EXAMPLE 1 Running brake operated by manual brake control or by the control device.

- b) The wheelchair shall have a running brake which, when operated after the wheelchair has been put into freewheel mode, shall bring the wheelchair to a stop.

NOTE 1 This requirement can be met by a brake which operates when freewheel mode is ended, if that brake provides the required function. See Note 2 and [10.3](#).

The maximum stopping distances of [Table 4](#) do not apply for a running brake operated after the wheelchair has been put into freewheel mode.

- c) The risk management process shall address risks due to loss of braking if a wheel loses contact with the ground (see [6.1](#)).

EXAMPLE 2 Loss of braking in a pair of wheels driven by a differential, caused by lifting of one wheel.

- d) The wheelchair shall have an automatic brake, which operates independently of tyre wear and tyre inflation pressure and which is operated by releasing the control device to achieve a zero speed command.

EXAMPLE 3 Spring-loaded disc brake.

- e) The wheelchair shall have a parking brake which operates independently of tyre wear and tyre inflation pressure.

EXAMPLE 4 Drum brake in wheel hub or spring-loaded disc brake.

- f) Parking brakes shall meet the parking brake effectiveness requirement in [Table 3](#) when tested in accordance with [10.2.2.2](#).
- g) Parking brakes shall be operable when there is no power from the battery supplying the drive system.
- h) Parking brakes shall be operable when the wheelchair is in freewheel mode (see Note 1).
- i) If they are subject to wear, parking brakes shall have provision for adjustment and/or replacement as specified by the manufacturer.
- j) If the wheelchair is fitted with arm supports that can be moved or removed to enable transfer of the occupant into or out of the wheelchair, when tested in accordance with [10.2.2.3](#), engaged parking brakes shall not have parts that protrude above the level of the occupied seat that can make contact with the occupant during transfer.
- k) When parking brakes are tested in accordance with [10.2.2.4](#), no parking brake mechanism shall move from the pre-set position and no component or assembly of parts shall show visible signs of cracks, breakages, gross deformations, free play, loss of adjustment, or any other damage, that adversely affect the function of the wheelchair.
- l) After testing of the parking brake in accordance with [10.2.2.4](#), parking brakes shall meet the parking brake effectiveness requirement in [Table 3](#) when tested again in accordance with [10.2.2.2](#).

NOTE 2 Braking functions can be combined in one device, for example a spring-loaded disc brake can combine automatic brake and parking brake, and can also act as a running brake when exiting freewheel mode.

NOTE 3 The wheelchair can be subject to national requirements for brakes.

## 10.2.2 Test methods

### 10.2.2.1 Determination of the effectiveness of running brakes

Perform the tests for normal, reverse command and emergency operation specified in 7.3, 7.4 and 7.5 of [ISO 7176-3:2012](#) using the loaded wheelchair on the horizontal and on the steepest slope specified in [ISO 7176-3:2012](#) or the rated slope, whichever is steepest. The wheelchair fails the requirement if the maximum stopping distance specified in [Table 4](#) of this document is exceeded on the horizontal, or if the wheelchair fails to stop on the test slope.

### 10.2.2.2 Determination of effectiveness of parking brakes

- a) Adjust the parking brake in accordance with the manufacturer's instructions without exceeding the operating force requirements stated in [Table 3](#).
- b) Test the loaded wheelchair facing uphill in accordance with [ISO 7176-3:2012](#), with the test plane inclined to the horizontal at the applicable angle stated in [Table 3](#) for the type class of the wheelchair or at the rated slope specified by the manufacturer, if it is greater.
- c) Repeat b) with the wheelchair facing downhill.
- d) Determine whether the parking brake meets the requirement.

### 10.2.2.3 Protrusion of parts of the parking brakes

- a) Engage the parking brake.
- b) Move or remove the arm support to enable transfer.
- c) Identify any parts of the parking brake that protrude above the plane of the lower surface of the thigh loading plate of the test dummy.
- d) Determine whether the parking brake meets the requirement.

### 10.2.2.4 Fatigue strength of parking brakes

- a) The parking brake may be tested in accordance with b) to g) below, or as specified in [ISO 7176-8:2014](#), 10.5.
- b) Carry out the test with the parking brake mounted on the wheelchair or mounted on a suitable test fixture that simulates mounting on the wheelchair. If the wheelchair is fitted with two identical brakes (left and right), test only one of the brakes.
- c) Adjust the parking brake in accordance with the manufacturer's instructions without exceeding the operating force requirements stated in [Table 3](#).
- d) Set up the means for moving the brake lever ([4.12](#)) so that no twisting or bending forces are applied to the brake lever.
- e) Move the lever operating the brake smoothly from the non-braking position to the braking position for 60 000 cycles at a frequency not greater than 0,5 Hz. Carry out maintenance during testing only in accordance with the manufacturer's instructions.
- f) Inspect the brake mechanism and determine whether it has met the requirement.
- g) If a test fixture was used, return the brake mechanism to the wheelchair.

## 10.3 Freewheel device

The wheelchair shall be fitted with a freewheel device that shall:

- be accessible and operable by the occupant or an assistant or both in accordance with the manufacturer's intended use of the wheelchair;
- be within the reach space shown in [Figure 1](#), if the wheelchair is intended to be operated by the occupant;
- be within the reach space shown in [Figure 2](#), if the wheelchair is intended to be operated solely by an assistant;
- have operating forces for engaging and disengaging that do not exceed those stated in [Table 3](#);
- be operable without detaching any parts;
- not depend on the battery power supplying the motor drive system;
- have two defined positions including clear indication of freewheel mode and drive mode;
- prevent use of the wheelchair's drive system, if the freewheel device is activated.

These requirements apply in addition to those concerning non-powered mobility stated in [ISO 7176-14:2008](#).

A battery independent from the motor drive battery may be used to supply energy to enable freewheel mode.

NOTE An audible alarm activated when the freewheel device is in operation and deactivated when the drive and braking systems are fully operational can assist the occupant and/or assistant.

Freewheel devices shall be protected against activation caused by accidental contact.

EXAMPLE A suitable shape and location for the means for disengagement.

## 11 Operations

### 11.1 Operations intended to be carried out by the occupant and/or assistant

Wheelchairs shall be designed to facilitate ease of operation by the occupant and/or assistant as specified in the manufacturer's instructions.

Examples include:

- operation of adjustable seating and adjustment of postural supports;
- use of detachable components, including removable arm supports, lower leg support assemblies, etc., to facilitate safe transfers into and out of the wheelchair;
- use of folding mechanisms, including folding frames, etc., to facilitate storage and transportation of unoccupied wheelchairs;
- carrying out maintenance, including use of tools, etc.;
- use of manual steering controls;
- use of braking systems and freewheel devices;
- use of assistant controls;
- use of control devices.

### 11.2 Controls intended for operation by the occupant

Controls intended to be operated by the occupant while seated shall be within the occupant reach space shown in [Figure 1](#).

The following controls, if they are fitted and intended to be operated by the occupant, are included:

- on/off switch or key;
- speed regulator;
- speed pre-setting;
- running brake;
- parking brake;
- acoustic warning device;
- direction indicator;
- direction switch;
- control device;
- lighting controls;

- seating adjustments;
- detachable components, including removable arm supports, lower leg support assemblies, etc., to facilitate safe transfers into and out of the wheelchair;
- steering controls;
- freewheel device.

### 11.3 Controls intended for operation by an assistant

Controls intended to be operated by an assistant shall be within the reach space shown in [Figure 2](#).

Examples include:

- brakes;
- control devices;
- push handles; and
- electrical ancillary equipment.

### 11.4 Assistant control unit, push handles and handgrips

#### 11.4.1 Requirements

Switches intended to be operated by an assistant while driving the wheelchair shall be attached to an assistant control unit.

When an assistant control unit is fitted:

- the unit shall be positioned behind the wheelchair's back support, between 900 mm and 1 200 mm from the floor to the centre of the operating means for the control device (e.g. joystick handle); and
- there shall be a means to support the assistant's hand or hands used to operate the control device.

When push handles are fitted, no part of the wheelchair shall lie within a space to the rear of the wheelchair bounded by the following:

- a plane at 85° to the horizontal, that touches the rearmost points of the push handles as shown in [Figure 5](#);
- two planes not less than 350 mm apart equidistant from a vertical plane parallel to the forward direction of travel that bisects the wheelchair, unless the intended occupant is a child;
- the horizontal test plane.

When the wheelchair is fitted with push handles, the handgrips shall be at least 75 mm in length and between 20 mm and 50 mm in diameter.

When push handles are fitted with controls that are intended to be used by being gripped by one hand, the grip width when no force is applied shall not be greater than 100 mm and should not be greater than 80 mm (see [Figure 3](#)).

#### 11.4.2 Test method

- Place the wheelchair in the test area of the horizontal test plane.
- If an assistant control device is fitted, note its position and measure the height of its operating means above the test plane.



- c) Project the planes specified in [11.4.1](#) and determine whether any part of the wheelchair lies within the enclosed space.
- d) Measure the dimensions of the handgrips on the push handles.
- e) Where applicable, measure the grip width of the controls fitted to the push handles that are intended to be used by being gripped by one hand.
- f) Inspect the wheelchair for means to support the assistant's hand or hands used to operate the control device while the wheelchair is being driven.
- g) Record whether the wheelchair has met the requirements.

## 11.5 Operating forces

### 11.5.1 Requirements

All controls, except for means to operate brakes, shall have operating forces for engaging and releasing that do not exceed those stated in [Table 3](#) when tested in accordance with [11.5.2](#).

NOTE Requirements and test methods for means to operate brakes are given in [10.1](#).

In addition, to achieve the intended function of the system or device being operated, for knobs intended to be gripped and turned by one hand:

- where the diameter of the knob is greater than or equal to 25 mm and the force is transmitted by friction, the numerical value of the torque, expressed in Nm, shall not be greater than 0,05 times the numerical value of the diameter of the knob, expressed in mm; and
- where the diameter of the knob is less than 25 mm diameter, the numerical value of the torque, expressed in Nm, shall not be greater than 0,025 times the numerical value of the diameter of knob, expressed in mm.

### 11.5.2 Test method

- a) Position a means to apply force or torque as applicable:
  - 1) where the operation is performed by pushing or pulling, position the means to apply force parallel to the direction of operation and in the middle of the knob or button;
  - 2) in the case of a lever of length 30 mm or greater, position the means to apply force at a distance of 15 mm from the end of the operating lever;
  - 3) in the case of a lever of length less than 30 mm, position the means to apply force at the midpoint of the lever;
  - 4) for a turning knob, use a suitable means (e.g. a force gauge) to measure torque concentrically on the knob.
- b) Gradually increase the force or torque until the intended function of the system or device as specified by the manufacturer's instructions is achieved.
- c) Measure and record the maximum operating force.
- d) Perform b) to c) three times in total.
- e) Calculate and record the arithmetic mean of the three recorded measurements.

## 11.6 Occupied seating adjustments

### 11.6.1 Requirements

If the manufacturer specifies that the seating can be adjusted by an assistant or the occupant or both while the occupant is seated:

- the assistant and/or the occupant shall not have to apply or withstand a force (e.g. the combined weight of the occupant and the seating) which presents a moving and handling safety hazard to the assistant and/or the occupant; and
- movement of the seating, whether continuous or incremental, shall automatically be prevented when the assistant or occupant releases the means of operation.

EXAMPLE Ratchet that locks automatically when the assistant lets go of a handle.

Controls for seating adjustments intended to be operated by the occupant shall be accessible to the occupant from all seating positions.

NOTE The lighter shaded region of [Figure 1](#) shows the reach space for the occupant in relation to the position of the back support reference plane and the seat reference plane (see ISO 7176-7:1998).

### 11.6.2 Test method

- a) Adjust the seating as specified in the manufacturer's instructions.
- b) Record whether the wheelchair has met the requirements.

## 12 Electrical systems

### 12.1 General requirements

The wheelchair shall conform to the requirements of [ISO 7176-14:2008](#), except as specified in [9.5.3](#).

The wheelchair shall conform to the requirements of [ISO 7176-21:2009](#).

NOTE [ISO 7176-21:2009](#) does not specify radiated emissions tests for movement of parts of the body support system.

### 12.2 Circuit protection

#### 12.2.1 Requirement

Operation of the circuit protection for each of the following functions shall not affect the operation of the remaining functions:

- a) electrically powered driving, braking and steering;
- b) electrically powered parts of the body support system;
- c) electrically powered lights, direction indicators and hazard warning flashers.

NOTE List item a) includes powered direct steering.

#### 12.2.2 Preparation

Examine the wheelchair and its circuit diagram to locate:

- a) conductors for each motor and actuator used to drive, brake and/or steer the wheelchair;

- b) conductors for each motor and actuator used to move parts of the body support system;
- c) conductors for each light, direction indicator and hazard warning flasher.

### 12.2.3 Test method

- a) For each pair of conductors identified in [12.2.2](#) a) in turn, apply a short circuit between them and operate the control device so that any related circuit protection can operate, then attempt to operate the functions identified in [12.2.1](#) b) and c) and observe whether their operation is affected.
- b) For each pair of conductors identified in [12.2.2](#) b) in turn, apply a short circuit between them and operate the controls for the body support system so that any related circuit protection can operate, then attempt to operate the functions identified in [12.2.1](#) a) and c) and observe whether their operation is affected.
- c) For each pair of conductors identified in [12.2.2](#) c) in turn, apply a short circuit between them and operate the lighting controls so that any related circuit protection can operate, then attempt to operate the functions identified in [12.2.1](#) a) and b) and observe whether their operation is affected.

## 12.3 Battery chargers

### 12.3.1 General

Battery chargers for wheelchairs shall conform to the requirements of [ISO 7176-25:2013](#), with the following modification.

*5.1.2.2 is replaced by the following:*

Battery chargers shall meet the requirements of EN 60335-2-29:2004 <sup>14)</sup> for class II appliances. The applicable electrical requirements of EN 60601-1:2006 <sup>15)</sup> for class II ME equipment may be applied as an alternative to the applicable electrical requirements of EN 60335-2-29:2004 <sup>16)</sup>.

In addition, wheelchairs that include an on-board battery charger shall conform to the applicable electrical requirements of EN 60601-1:2006 <sup>17)</sup>.

Battery chargers shall conform to the requirements of [ISO 7176-21:2009](#).

### 12.3.2 Operation

Battery chargers shall operate without the need for intervention or supervision apart from connecting and turning on at the start of charging, and turning off and disconnecting at the end of charging.

### 12.3.3 Manual adjustment for battery type

Where a battery charger is intended for use with more than one type of battery, and a manual operation is necessary to select the battery type:

- the selected battery type shall be conspicuously visible from the exterior of the battery charger;
- it shall not be possible to select the battery type without a tool, key entry combination or similar means for restricting access; and

---

14) EN 60335-2-29:2004 is amended by EN 60335-2-29:2004/A2:2010 and EN 60335-2-29:2004/A11:2018.

15) EN 60601-1:2006 is amended by EN 60601-1:2006/A2:2021, EN 60601-1:2006/A12:2014 and EN 60601-1:2006/A1:2013; and corrected by EN 60601-1:2006/corrigendum Mar. 2010.

16) EN 60335-2-29:2004 is amended by EN 60335-2-29:2004/A2:2010 and EN 60335-2-29:2004/A11:2018.

17) EN 60601-1:2006 is amended by EN 60601-1:2006/A2:2021, EN 60601-1:2006/A12:2014 and EN 60601-1:2006/A1:2013; and corrected by EN 60601-1:2006/corrigendum Mar. 2010.

- the method for selecting the battery type shall not consist of operations which are performed in normal use of the charger.

## 12.4 Charging connector

The wheelchair shall have a charging connector that is readily accessible and operable by the occupant or an assistant or both in accordance with the manufacturer's intended use of the wheelchair.

NOTE The shape and position of the charging connector are important factors contributing to the ease and safety of operation.

The requirement is verified by inspection.

## 12.5 Battery enclosures and containers

Battery enclosures and containers shall provide protection so that it should not be possible for liquids dripping from above to enter into them and onto any cell or battery they contain.

EXAMPLE Rainwater, urine.

## 12.6 Emergency stop

The wheelchair shall be fitted with one or more emergency stop devices to enable actual or impending danger to be averted.

EXAMPLE An on-off switch. See [ISO 7176-14:2008](http://www.china-gauges.com/), 8.7, switch-off while driving.

Each emergency stop device shall:

- be clearly identifiable, clearly visible and quickly accessible by the intended operator; and
- stop the hazardous process as quickly as practicable, without creating additional risks.

Once active operation of the emergency stop device has ceased following a stop command, that command shall be sustained by the wheelchair until that engagement is specifically overridden. It shall not be possible to engage the device without triggering a stop command. It shall be possible to disengage the device only by an appropriate operation, and disengaging the device shall not restart the wheelchair but only permit restarting.

The emergency stop function shall be available and operational at all times, regardless of the operating mode.

Emergency stop devices shall be a back-up to other safeguarding measures and not a substitute for them.

Additional emergency stop devices may be attached to a wheelchair to be operated by an assistant. Where the intended occupant has an impairment which restricts their ability to operate an emergency stop device, the risk management process ([6.1](#)) should take this into account.

## 12.7 Lighting

Wheelchairs intended by the manufacturer for outdoor use shall be supplied with integral lighting suitable for the operations concerned where the absence thereof is likely to cause a risk despite ambient lighting of normal intensity.

EXAMPLE Headlights, rear lights, illuminated controls.

NOTE 1 This requirement is derived from Directive 2006/42/EC [[15](#)] on machinery.

Wheelchairs can be subject to national requirements for lighting and reflectors.

If there are no national requirements, the wheelchair is expected to conform to relevant lighting requirements in automotive Regulations of the European Union (e.g. Regulation 661/2009 [18]).

NOTE 2 [Annex C](#) contains recommendations for wheelchair lighting.

### 12.8 Switching off while driving

If the wheelchair is switched off while driving on the horizontal, it shall come to a stop within the maximum stopping distances specified in [Table 4](#).

NOTE See also [ISO 7176-14:2008](#), 8.7.

### 12.9 Software

Software that is embedded in the wheelchair or is an integral part of the wheelchair, and the malfunction of which can give rise to a hazardous situation, shall be developed and maintained in accordance with EN 62304:2006<sup>18)</sup>.

### 12.10 Lithium cells and batteries

Sealed secondary lithium cells and batteries containing non-acid electrolyte shall conform to the requirements of EN 62133-2:2017<sup>19)</sup>.

### 12.11 Remote control

Where remote control is used for any moving part of the wheelchair or any lighting function, the following aspects shall be included in the risk management process:

- loss of signal;
- signal errors;
- reliability level;
- correct pairing between the remote control and the wheelchair;
- correct identification of the paired remote control and wheelchair to the operator;
- interference from multiple remote controls;
- security and malicious interference;
- reliability of software in the remote control;
- gradual loss of power in the remote control;
- range.

This requirement applies regardless of whether the remote control acts between components of the wheelchair or between an external device and the wheelchair.

---

18) EN 62304:2006 is amended by EN 62304:2006/A1:2015.

19) EN 62133-2:2017 is amended by EN 62133-2:2017/A1:2021.

## 13 Information supplied by the manufacturer

### 13.1 General

Each wheelchair shall be provided with documentation and labelling that conform to the applicable requirements in EN ISO 20417:2021 in addition to the requirements specified in this document.

The manufacturer shall provide the documentation in three separate sections: pre-sale, user and servicing information, as specified in [13.2](#), [13.3](#) and [13.4](#) respectively. These may be provided as separate printed documents or in other forms of media to meet the needs of individual occupants or their assistants.

### 13.2 Pre-sale information

Pre-sale information shall include the following:

- a) information on how to obtain the user information in a format appropriate for use by visually impaired people;
- b) a description of the intended occupant of the wheelchair, including the occupant's mass;
- c) the intended operator (occupant, assistant or both), intended use and the intended environment;
- d) the type class of the wheelchair: Class A, Class B or Class C;
- e) the overall dimensions (width, length and height) of the wheelchair and its mass when it is ready for use and, if applicable, when it is folded and/or dismantled for storage or transportation;
- f) the minimum width of corridor in which the wheelchair can be turned to face the opposite direction;

NOTE The applicable measurement for wheelchairs with full differential steering is the pivot width, while for wheelchairs with limited differential steering or direct steering, it is the reversing width. See [A.2.2](#).

- g) the rated slope, expressed in degrees;
- h) the standard options that are available for the wheelchair;
- i) if the wheelchair can be dismantled or has any removable parts, the mass of the heaviest part;
- j) a statement that the wheelchair is intended to be used as a seat in a motor vehicle, or a warning that the wheelchair is not intended to be used as a seat in a motor vehicle;
- k) the theoretical continuous driving distance range, expressed in kilometres, that the wheelchair can travel under its own power on the horizontal when tested in accordance with [ISO 7176-4:2008](#), with the addition of a note explaining that the distance will be reduced if the wheelchair is used frequently on slopes, rough ground or to climb kerbs, etc.;
- l) the maximum height of kerb which the wheelchair can descend safely;
- m) if a programmable controller is fitted, information on the method of programming, the competency required to carry out the programming and the effects it can have on driving performance.

### 13.3 User information

User information shall be provided by the manufacturer with each wheelchair. Further copies shall also be available for any subsequent user of the wheelchair. User information shall contain the following where applicable:

- a) the unique identification number of the wheelchair or information on the location of the unique identification number on the wheelchair;

- b) any adjustment or settings required before the wheelchair can be used and warnings of how adjustments or settings affect stability;
- c) information on any adjustments that can be made, and the competency required to carry out these adjustments;
- d) instructions on operation of all controls, including brakes;
- e) instructions on how to engage and disengage the drive system;
- f) the wheelchair manufacturer's recommended tyre pressure (kPa), expressed in kPa, bar or PSI;
- g) instructions for dealing with tyre punctures;
- h) the battery type and nominal voltage;
- i) instructions for battery maintenance;
- j) instructions for operating the battery charger, including warnings regarding any potential safety hazards (e.g. a possibility of gas accumulating in the charging area, use of the wrong type of battery charger);
- k) if required by the risk analysis, instructions for fitting an additional emergency stop device where the intended occupant has an impairment which can restrict their ability to operate one;
- l) instructions on whether and how the wheelchair can be folded to assist in storage or transport;
- m) instructions on dismantling and re-assembly of the wheelchair or any removable parts;
- n) instructions regarding transport of the wheelchair when it is unoccupied (e.g. in a car or aeroplane);
- o) if the manufacturer specifies that the wheelchair is intended for use as a seat in a motor vehicle, the method of attaching wheelchair tiedown and occupant restraints, and recommendations about suitable tiedown and restraint systems;
- p) if the manufacturer specifies that the wheelchair is not intended for use in the motor vehicle, a warning to that effect;
- q) instructions on how to use the means for maintaining a sitting posture (see [9.4](#)) and the circumstances in which it should be used;
- r) instructions on how to obtain and fit the means for maintaining a sitting posture (see [9.4](#)) if it is not supplied with the wheelchair;
- s) the positions of points intended to carry additional loads;  
EXAMPLE      Grocery basket, backpack hook.
- t) instructions for preparing the wheelchair for long-term storage (e.g. longer than four months) and for preparing it for use afterward;
- u) warning that the wheelchair can disturb the operation of devices in its environment that emit electromagnetic fields (e.g. alarm systems of shops, automatic doors, etc.);
- v) a warning that the driving performance of the wheelchair can be influenced by electromagnetic fields (e.g. those emitted by electricity generators or high-power sources);
- w) a warning that the stopping distance on slopes can be significantly greater than on level ground;
- x) information on the recycling of used batteries and of the wheelchair;
- y) if the characteristics of the wheelchair (including the occupant as applicable) exceed the limits specified in Appendix M of Commission Regulation (EU) No 1300/2014 [[19](#)], a statement to that effect (see [Annex D](#) for additional information);

- z) information on how to find out about product safety notices and product recalls, for example by ensuring the supplier has up-to-date contact details;
- aa) the expected service life of the wheelchair;
- bb) information on how to get repairs and servicing;
- cc) warranty information.

### 13.4 Service information

The service information shall contain instructions necessary for the maintenance, adjustment and repair of the wheelchair and for the replacement of parts.

### 13.5 Labelling

The manufacturer shall apply permanent labelling for the following:

- a) the maximum load of the wheelchair, i.e. the total of the maximum occupant mass and the maximum mass of any other items intended to be carried by the wheelchair;
- b) devices for disengagement of the drive system, showing engaged and disengaged positions, including a warning that the drive system should be re-engaged before an occupant is left unattended or attempts to operate the wheelchair;
- c) for wheelchairs where the intended use includes use as a seat in a motor vehicle, the position of attachment points for wheelchair tie-down and occupant restraint systems (WTORS);
- d) for wheelchairs not intended to be used as a seat in a motor vehicle, a warning to that effect;
- e) for Class A wheelchairs not intended for use outdoors, a warning to that effect.

## 14 Test report, tables and figures

The test report shall contain the following information:

- a) a unique report number;
- b) the name and address of the testing institution;
- c) the date of issue of the test report;
- d) a reference to this document, i.e. [EN 12184:2022](#);
- e) the name and address of the manufacturer of the wheelchair;
- f) a description of the sample including the manufacturer's or vendor's trademark, model or type, unique identification number and any variations or accessories fitted;
- g) the manufacturer, type and model of controller and motors and the type and capacity of the batteries fitted to the wheelchair during the tests;
- h) the supplier of the sample;
- i) details of the set-up of the wheelchair as specified in [ISO 7176-22:2014](#), including details of how it was equipped and adjustments;
- j) the masses of the dummies or human test occupants and weights used;
- k) where the controller is programmable, the settings used while testing;
- l) a photograph of the sample equipped as during the test;



- m) the results of the tests;
- n) if not all of the requirements of this document have been applied (see [Annex G](#)), a list of the requirements that have been applied and those that have not;
- o) a statement as to whether or not the tested sample has met all of the applicable requirements of this document and a list of all the applicable requirements it has not met.

<http://www.china-gauges.com/>

Table 3 — Requirements for driving characteristics of type classes

Driving characteristics	Test Method	Requirements		
		Class A	Class B	Class C
Rated slope	<a href="#">8.1.2.2</a>	3°	6°	10°
Dynamic stability	<a href="#">8.1.5.2</a>			
– starting forward uphill		3°	6°	10°
– stopping forward uphill		3°		10°
– stopping forward downhill		3°	6°	10°
– stopping backward downhill		3°	6°	10°
– turning on a slope		No tipping beyond balance point shall occur	No tipping beyond balance point shall occur	No tipping beyond balance point shall occur
Static stability	<a href="#">8.1.7.2</a>			
– all directions		6° or the rated slope claimed by the manufacturer if greater	9° or the rated slope claimed by the manufacturer if greater	15° or the rated slope claimed by the manufacturer if greater
Maximum operating forces				
Brake levers	<a href="#">10.1.2</a>			
Freewheel lever and controls	<a href="#">11.5.2</a>			
– single finger operation		5 N	5 N	5 N
– more than one finger operation		13,5 N	13,5 N	13,5 N
– whole-hand operation		60 N	60 N	60 N
– combined hand-and-arm operation		60 N	60 N	60 N
– foot operation pushing		100 N	100 N	100 N
– foot operation pulling		60 N	60 N	60 N
Parking brake effectiveness	<a href="#">10.2.2.2</a>	6° or the rated slope claimed by the manufacturer if greater	9° or the rated slope claimed by the manufacturer if greater	15° or the rated slope claimed by the manufacturer if greater
Maximum speed	<a href="#">8.1.8</a>			
– forwards horizontal		15 km/h	20 km/h	20 km/h
– reverse horizontal		70 % of the maximum forward speed or 5 km/h whichever is lower	70 % of the maximum forward speed or 5 km/h whichever is lower	70 % of the maximum forward speed or 5 km/h whichever is lower
Obstacle climbing and descending	<a href="#">8.1.6.2</a>			
– obstacle height		15 mm	50 mm	100 mm
Theoretical distance range	<a href="#">8.1.9.2</a>	15 km	25 km	35 km

Driving characteristics	Test Method	Requirements		
		Class A	Class B	Class C
Ground unevenness	<a href="#">8.1.3.3</a>	10 mm	30 mm	50 mm

Table 4 — Requirements for horizontal stopping distance for all type classes

Speed km/h	Maximum stopping distance m
4,0	0,6
5,0	0,8
6,0	1,0
7,0	1,2
8,0	1,5
9,0	1,8
10,0	2,1
11,0	2,5
12,0	2,9
13,0	3,4
14,0	3,9
15,0	4,5
16,0	5,2
17,0	5,9
18,0	6,6
19,0	7,3
20,0	8,0

Dimensions in millimetres

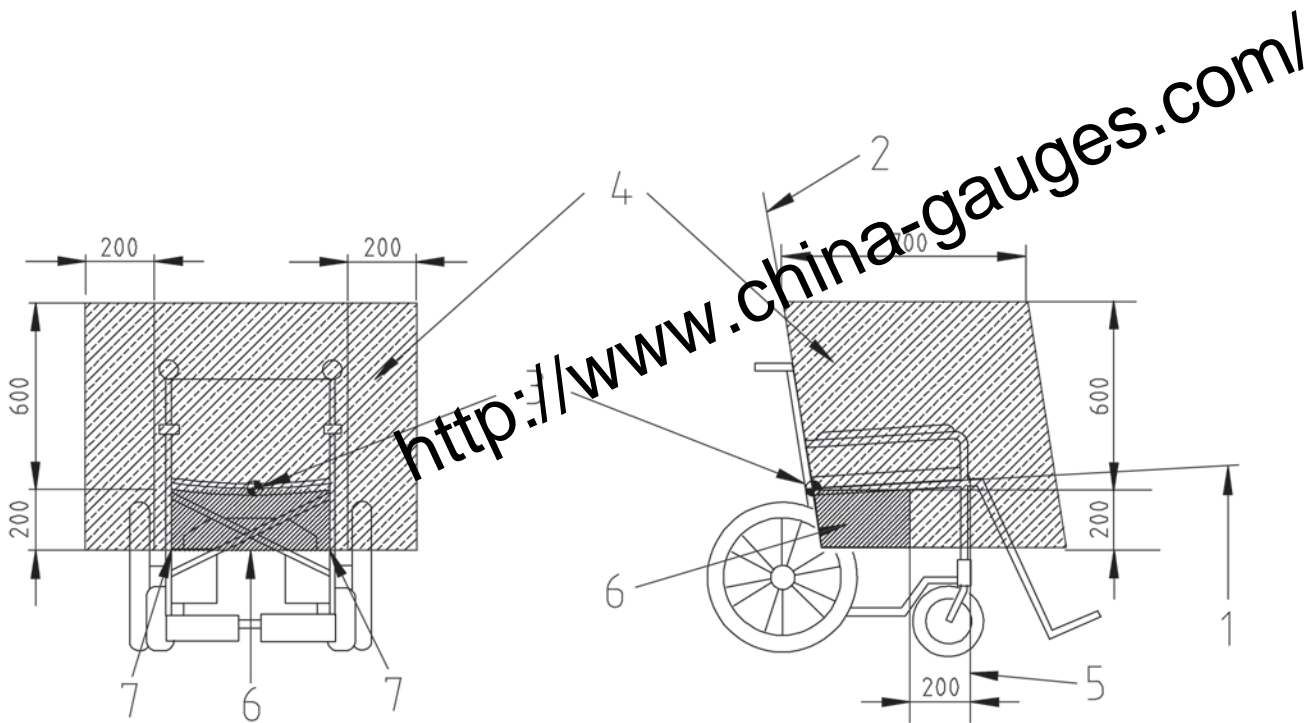

**Key**

- 1 seat reference plane
- 2 back support reference plane
- 3 seat reference point
- 4 occupant reach space
- 5 vertical line from the centre of the front edge of the seat
- 6 region below the rear of the seat that is excluded from the reach space
- 7 lateral extent of excluded region delimited by vertical lines from the sides of the seat

**Figure 1 — Occupant reach space**

Dimensions in millimetres

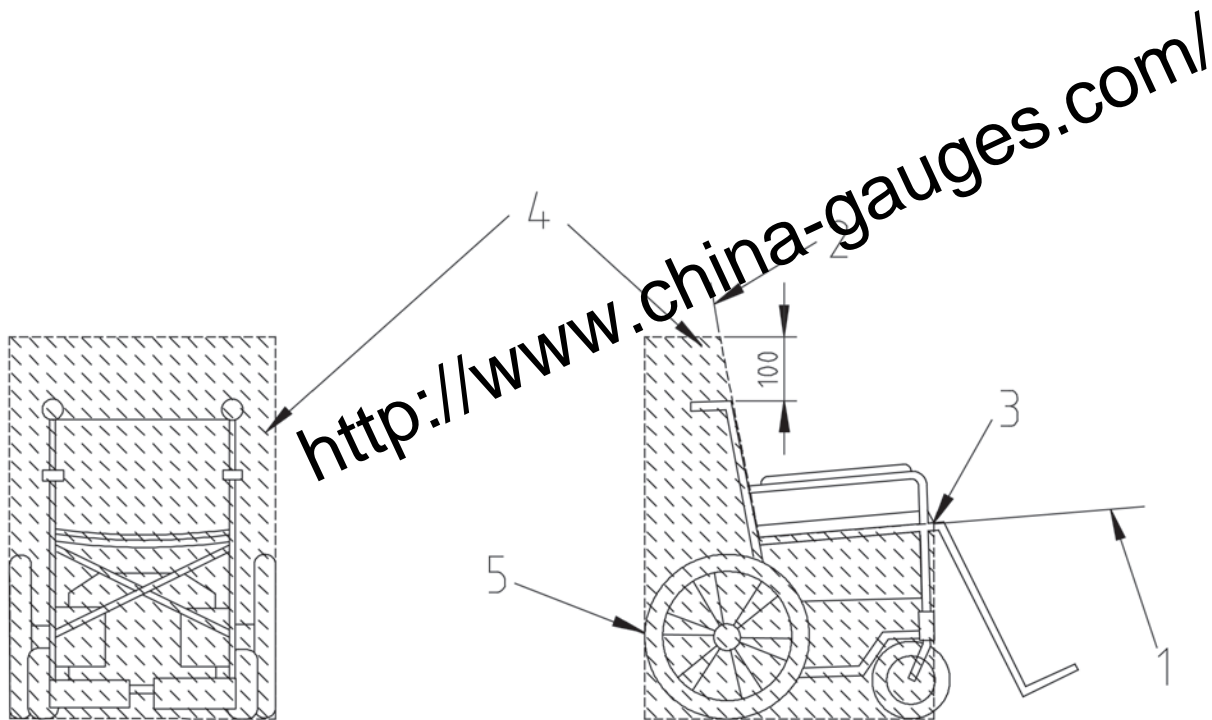

**Key**

- 1 seat reference plane
- 2 back support reference plane
- 3 front edge of seat
- 4 assistant reach space for controls
- 5 most rearward point of wheelchair

**Figure 2 — Assistant reach space for controls**

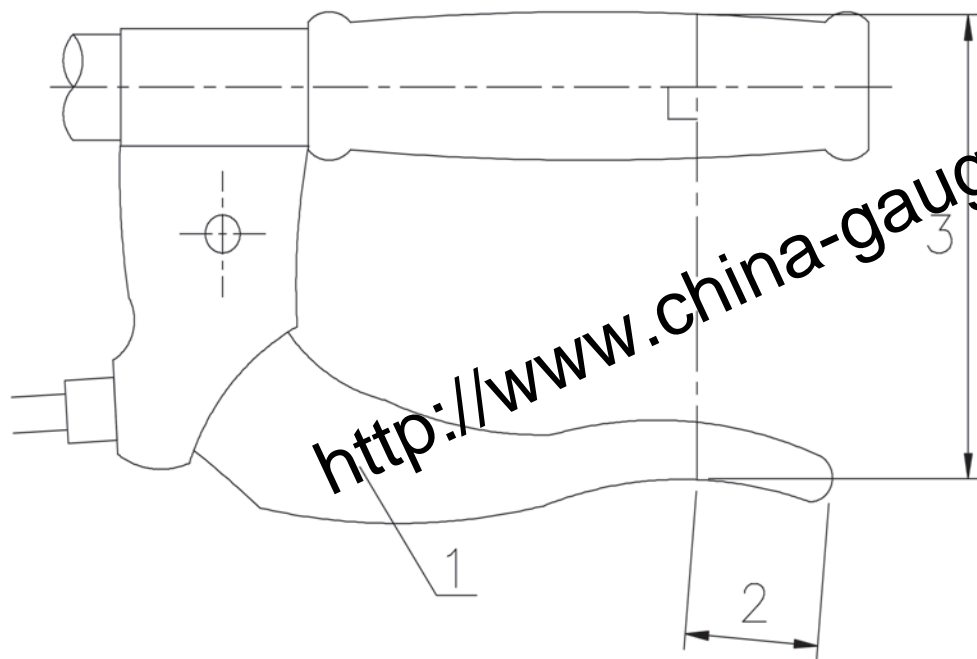

**Key**

- 1 lever gripped by the fingers of one hand
- 2 15 mm
- 3 grip width

**Figure 3 — Grip width**

Dimensions in millimetres

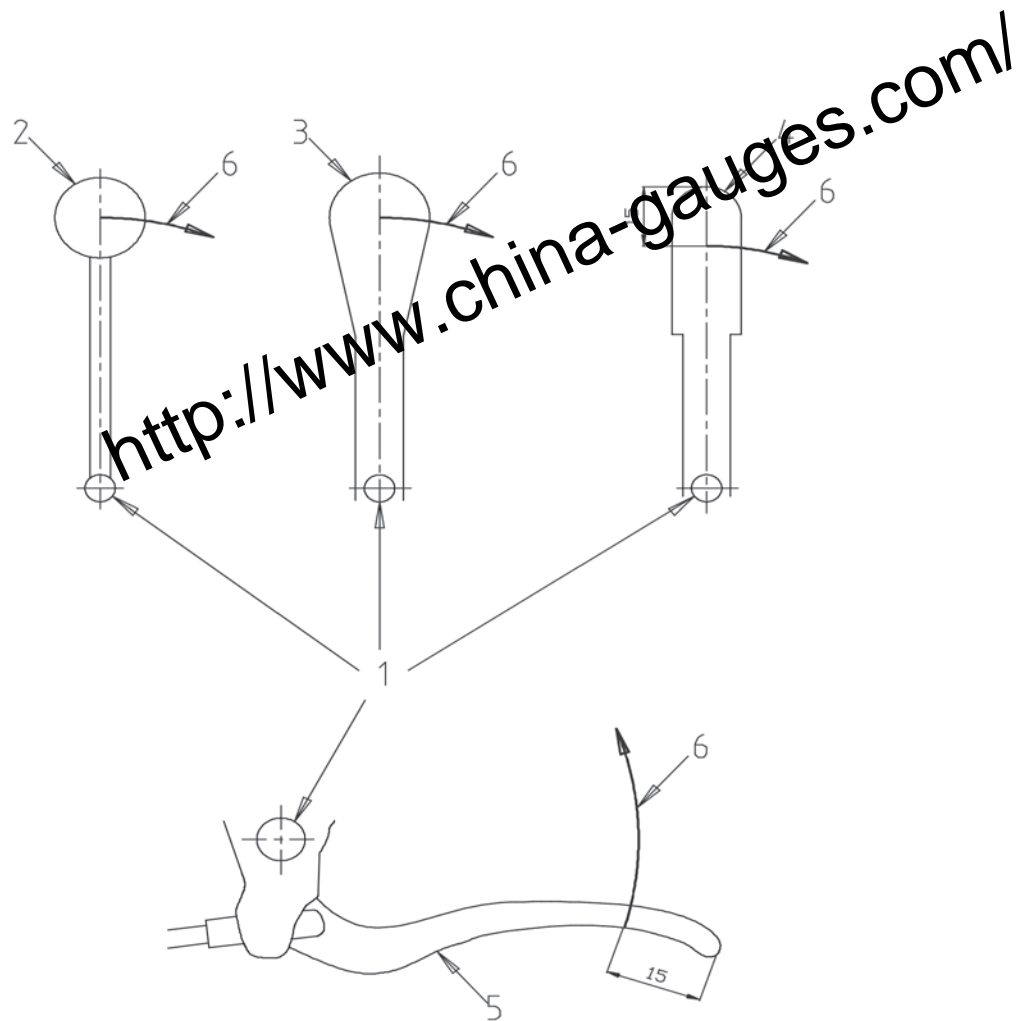

**Key**

- 1 fulcrum
- 2 generally spherical knob
- 3 tapered lever
- 4 parallel lever
- 5 bicycle-style lever
- 6 path of the point of application of the operating force

**Figure 4 — Application of forces to levers**

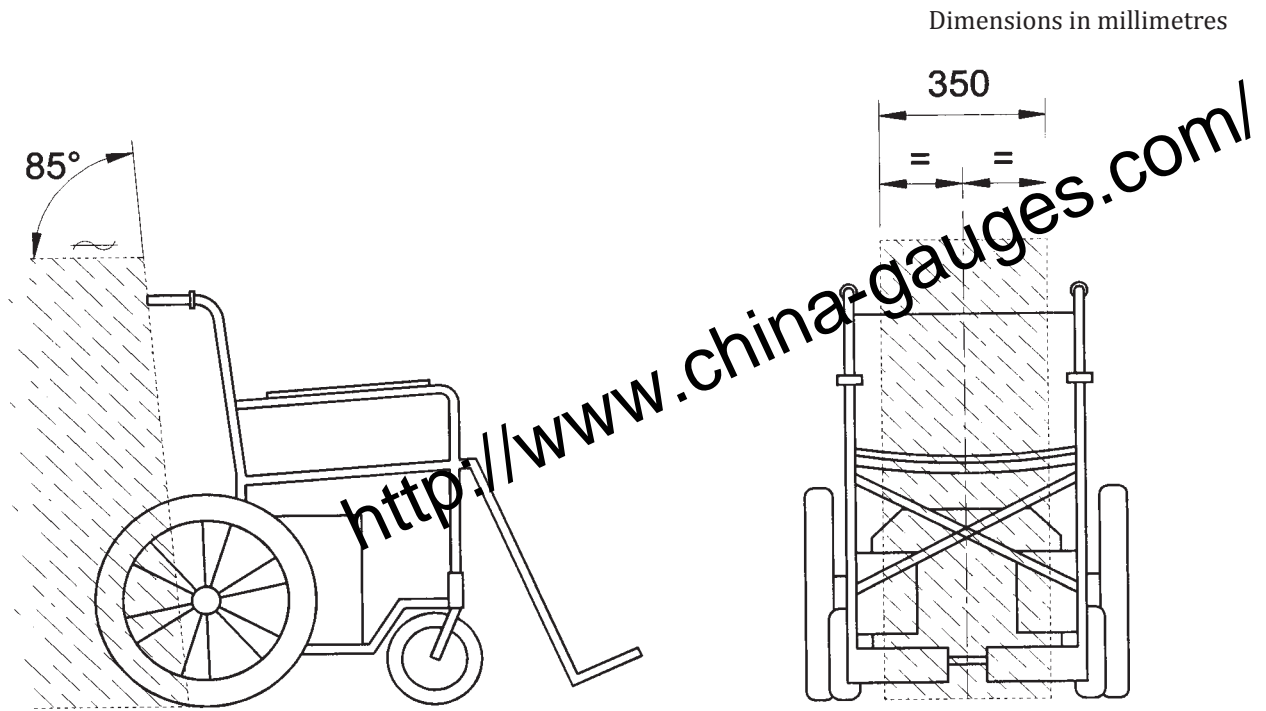
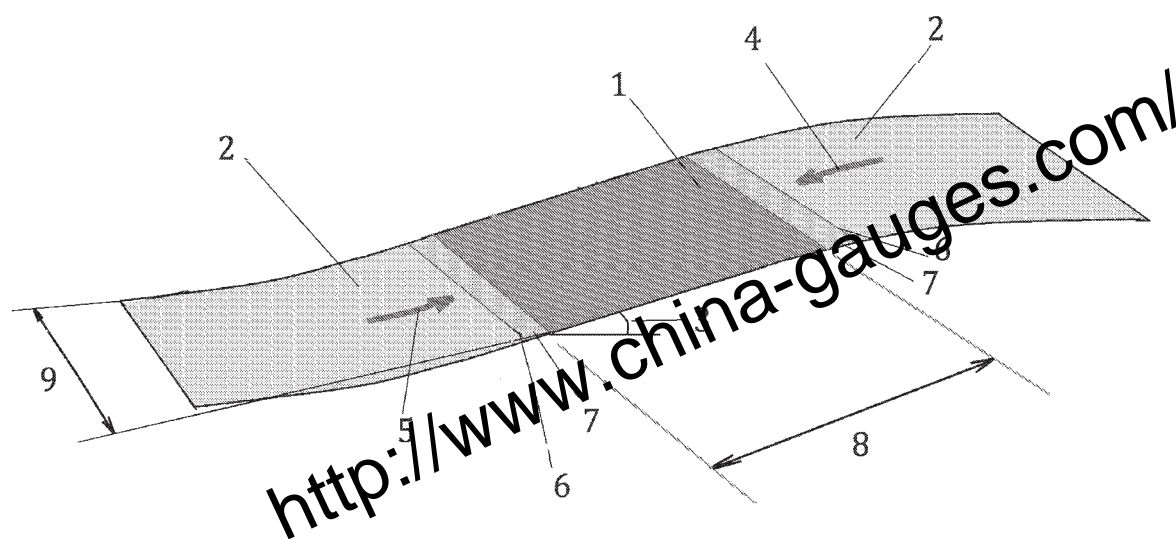

Figure 5 — Space for assistant movement





**Key**

- 1 test area
- 2 part of inclined test plane outside the test area
- 3 specified slope
- 4 downhill path
- 5 uphill path
- 6 edge of transition
- 7 transition zone
- 8 length of test area
- 9 width of test area

**Figure 6 — Inclined test plane**

## Annex A (informative)

### Recommendations for dimensions and manoeuvring space of electrically powered wheelchairs

#### A.1 Specific dimensions

##### A.1.1 Dimensions when ready for use

The overall width and full overall depth, when measured in accordance with [ISO 7176-5](#), should not be greater than the applicable values specified in [Table A.1](#) for the type class of the wheelchair.

##### A.1.2 Push handle height

The height of push handles, if fitted, should be between 900 mm and 1 200 mm when the wheelchair is set up as specified in [ISO 7176-22:2014](#).

##### A.1.3 Ground clearance

The ground clearance, when measured in accordance with the method specified in [ISO 7176-5](#), should not be less than the value specified in [Table A.1](#). This recommendation does not apply to wheelchairs designed for special purposes that are incompatible with the recommendation, e.g. stand-up wheelchairs and wheelchairs with a seat that lowers to ground level.

#### A.2 Manoeuvring space

##### A.2.1 Turning diameter

The turning diameter, as measured by the test specified in [ISO 7176-5](#), should not be greater than the value specified in [Table A.1](#) for the type class of the wheelchair.

##### A.2.2 Pivot width or reversing width

For wheelchairs with full differential steering, the pivot width, when measured in accordance with [ISO 7176-5](#), should not be greater than the value specified in [Table A.1](#) for the type class of the wheelchair.

For wheelchairs with limited differential steering or direct steering, the reversing width, when measured in accordance with [ISO 7176-5](#), should not be greater than the value specified in [Table A.1](#) for the type class of the wheelchair.

#### A.3 Speed settings

The pre-set value of the maximum speed should be limited to the value specified in [Table 3](#) for the type class of wheelchair.

If a maximum speed regulator is present, the highest values capable of being set by the operator should not exceed the value specified in [Table 3](#) for the type class of wheelchair.

It should not be possible to change other settings of the wheelchair without the aid of a tool, key entry combination or similar means for restricting access. If the means for restricting access is other than a tool, it should not consist of operations that are performed in normal use of the wheelchair.

**Table A.1 — Dimensions and manoeuvring spaces of electrically powered wheelchairs**

Dimensions	Class A mm	Class B mm	Class C mm
Full overall length – maximum	1 200	1 400	no recommendation
Overall width – maximum	700	700	800
Turning diameter – maximum	2 000	2 800	no recommendation
Pivot width – maximum	1 300	1 800	no recommendation
Reversing width – maximum	1 300	1 800	no recommendation
Ground clearance – minimum	30	60	80

#### A.4 Wheelchairs for use as seats in motor vehicles

Where the intended use of a wheelchair includes use as a seat in a road vehicle, the risk management process (6.1) should consider the dimensions and mass of the occupied wheelchair in relation to the following:

- the type of vehicle environment, such as a public transport bus, tram or taxi;
- the load-carrying capacity of a converted or adapted private passenger vehicle;
- the strength of securement anchorages and wheelchair tie-down equipment within a converted or adapted private passenger vehicle;
- the safe working loads (SWL) of boarding aids, such as ramps or passenger lifts; and
- the slopes of boarding aids and gaps between boarding aids and other surfaces.

## Annex B (informative)

### Recommended design features

#### B.1 Introduction

Since wheelchairs serve many different users who have many different requirements and demands, it is not possible to make the recommendations contained in this annex mandatory for every wheelchair. Manufacturers should follow the recommendations as far as possible and applicable, depending on the intended use of the wheelchair.

#### B.2 General recommendations

##### B.2.1 Anti-tip devices

If the wheelchair is fitted with anti-tip devices, they should not move from their pre-set positions or lose their function when preventing a loaded wheelchair from tipping.

Anti-tip devices should be positioned so they will not cause the wheelchair to exceed the applicable full overall length limit specified in [Table A.1](#), and they should not interfere with mounting or dismounting kerbs when in a non-working position.

Anti-tip devices should be labelled with a warning that the occupant should be informed when an anti-tip device is fitted or removed.

##### B.2.2 Component mass

If any parts can be removed from the wheelchair, or if the wheelchair can be dismantled, the maximum mass of any component should not exceed 10 kg.

##### B.2.3 Fittings and tools

All screws, fasteners and similar fittings should be of metric size as specified in [ISO 68-1](#). The number of tools required for their operation should be a minimum.

##### B.2.4 Tyres

The wheelchair should be fitted with tyres that do not mark indoor floors.

##### B.2.5 Surface temperature

The thermal properties of materials that come into direct contact with the occupant, e.g. control units or upholstered parts, should be considered when selecting these materials to avoid excessive surface temperatures when they are exposed to external sources of heat (e.g. sunlight).

##### B.2.6 Occupant transfer into or out of the wheelchair

When the manufacturer specifies that a sideways transfer can be made:

- arm supports should be movable or removable;

- lower leg support assemblies should be removable, and when they are removed, swung to the side or retracted, their mountings should not protrude more than 50 mm in front of the occupied seat nor protrude more than 20 mm above it, and no sharp edges or protrusions should be present.

When the manufacturer specifies that the occupant can make a sideways step to a standing position in front of the wheelchair, lower leg support assemblies should be removable.

When lower leg support assemblies are not removable, foot supports should be movable or removable so that the occupant has room to rise from a seated position in the wheelchair to a standing position. The underside of a movable foot support should not present any sharp edges or protrusions that can contact the occupant's lower legs or feet when the foot supports are raised.

### **B.2.7 Cleaning and disinfection**

The wheelchair should be easy to clean and should not incorporate features which will retain dust, liquid and/or contaminated material, except where the intended function of the wheelchair is to retain such material.

A wheelchair which can come into contact with body fluids should be able to be disinfected repeatedly by readily available disinfectants without damage to the wheelchair.

Parts of the wheelchair that are specified by the manufacturer to be washable by an automatic washing system should function normally after 50 wash cycles.

### **B.2.8 Indication for rated slope**

The wheelchair should have the provision for including a device which indicates or provides an alarm to the operator when 80 % of the rated slope is reached.

This indicator should operate when facing up a slope, down a slope, and across a slope.

### **B.2.9 Mirrors**

The wheelchair should have the capability of mounting a rear-view mirror or mirrors when required by the occupant.

NOTE This is essential where the occupant cannot rotate their upper body or neck to see behind them when seated in the wheelchair.

### **B.2.10 Head support**

If the use of the wheelchair allows the seat or the back support to be reclined to an angle of more than 25° to the vertical, the wheelchair should have a head support or provision to attach a head support.

The manufacturer of a wheelchair that has such provision should have a head support available as an option.

The "head support height above seat" dimension (see ISO 7176-7:1998, dimension 10) of the wheelchair should cover the range 680 mm to 844 mm in order to be appropriate for the body size of various occupants.

If a wheelchair is available with a head support, and the seat or the back support can be reclined to an angle of more than 25° to the vertical, the operator's manual should contain an instruction to use the head support when the seat or the back support is reclined.

### **B.2.11 Continuous operating forces**

Appropriate measures should be adopted wherever practicable to minimize the forces applied for extended periods of time by operators in normal use of the wheelchair.

### B.2.12 Cabins and covers

Where the wheelchair has a cabin or cover intended to enclose the occupant while driving:

- the occupant should have adequate visibility forwards, backwards and to both sides;
- wipers capable of continuous operation without operator intervention should be provided on forward-facing windows;
- mirrors should be provided (see [B.2.9](#));
- means to prevent or remove condensation on windows should be provided;
- access should be possible from both sides, to facilitate safe transfers into and out of the wheelchair;
- the risk management process should take into account the effects of wind on stability.

NOTE Wheelchairs with cabins may be subject to national legal requirements.

### B.2.13 Animal tissue

Tissue of animal origin or their derivatives can carry infection and microbial contamination. Manufacturers should examine them for signs of disease or contamination. This is particularly important when there is a possibility of contact with damaged skin.

Typical materials used in wheelchair seating are:

- leather;
- sheepskin.

### B.2.14 Ingress of liquids

Wheelchairs that are intended to be repeatedly immersed in water or other liquids should be constructed to withstand repeated immersion without causing a hazard.

### B.2.15 V-shaped openings

The internal angle of any V-shaped opening should be at least 75° to reduce the risk for the occupant to be trapped by the head or other part of the body.

### B.2.16 Surfaces, corners, edges and protruding parts

The provisions in [EN 1888-1](#), concerning hazardous edges and protrusions should be followed.

For guidance on test methods for protruding parts see [EN 716-2:2017](#), 5.10.

### B.2.17 Ergonomic principles

Guidance on the design and location of control actuators for operators of machinery is given in [EN 894-3](#). This guidance should be used with caution as occupants can need special features to suit their needs.

## B.3 Recommendations for performance characteristics

### B.3.1 Indication of electrical faults

The wheelchair should be equipped with a means for indicating fault(s) in its electrical system.

### B.3.2 Batteries and their containers

Batteries and battery containers should be resistant to mechanical damage (e.g. cracking).

Batteries should be removable from wheelchairs with powered seat lifts, with the seat at any position of its travel, if there is no manual operation of the seat lift when the power is off.

Batteries used for driving the wheelchair should be of the traction or semi-traction type.

Batteries for wheelchairs which can be used indoors (Class A and Class B) should be non-spillable.

NOTE Non-spillable batteries can be more acceptable for transport in aircraft and road vehicles than batteries containing free liquid electrolytes.

### **B.3.3 Control mechanism feedback**

The operator should receive feedback from a function's control mechanisms (e.g. light or sound, etc.) to verify that the function is actually operating.

### **B.3.4 Freewheel alarm**

When the freewheel device is operated, an auditory warning and/or a visual warning should be made until the freewheel device is deactivated and the drive and braking system is fully operational.

### **B.3.5 Maximum speed**

Operation of functions which can adversely affect the stability and safety of a wheelchair (e.g. elevating seats, elevating lower leg support assemblies and reclining back supports) should automatically reduce the maximum speed of the wheelchair.

## Annex C (informative)

### Recommendations for lighting and reflectors

#### C.1 General

Lighting equipment and light sources (e.g. exchangeable light bulbs) should be type-approved vehicle parts.

Only legally prescribed and authorized lighting equipment should be used.

Where lighting equipment is used without type approval, an independent evaluation report should be available.

A light is considered not to be present if it cannot be put into operation by simple installation of a light source and/or a fuse (see UNECE Regulation 48 [11]).

Lights and reflectors should be mounted securely on non-moveable parts of the wheelchair.

#### C.2 Headlights

Headlights should be adjustable.

The lowest point of a headlight reflector should not be less than 500 mm above the ground.

For wheelchairs with a maximum speed not exceeding 8 km/h, at least one white light should be provided.

For wheelchairs with a maximum speed exceeding 8 km/h, at least one white light with headlight effect should be provided, and each headlight should meet or exceed applicable requirements for bicycle front lights.

No more than two headlights should be used.

#### C.3 Lateral reflectors

Two yellow reflectors should be provided, one on each side of the wheelchair.

The highest point of a lateral reflector should be not more than 600 mm above the ground.

Each lateral reflector may form a horizontal or vertical band.

#### C.4 Rear lights

Two red rear lights should be provided.

The lowest point of a rear light should not be less than 350 mm above the ground.

The rear lights should be as far as possible from each other.

Separate fuses should be provided for each rear light.

Two additional red tail lights may be used.



### C.5 Rear reflectors

Two red rear reflectors should be provided.

Rear reflectors should not be triangular.

The highest point of a rear reflector should not be more than 900 mm above the ground.

The rear reflectors should be as far as possible from each other.

<http://www.china-gauges.com/>

## Annex D (informative)

### EN 12184 and rail interoperability

#### D.1 Background

Directive 2016/797 [20] concerns the interoperability of the European rail network. It provides for mandatory Technical Specifications for Interoperability (TSIs) to cover subsystems of the rail network. One TSI deals with rail infrastructure and passenger rolling stock subsystems in relation to 'persons with disabilities and persons with reduced mobility' (PRM). This document, Commission Regulation (EU) 1300/2014 [19], usually referred to as the PRM-TSI, was adopted by the European Commission on 18 November 2014.

The PRM-TSI specifies several aspects of rail infrastructure and rolling stock in relation to a notional wheelchair that meets limits for characteristics, including dimensions and occupied mass, specified in Appendix M of that document. These limits appear to be based on the results of the European COST 335 [12] study, with some modifications. The COST 335 study in turn made use of ISO 7193, which only specifies maximum overall dimensions for wheelchairs primarily intended for indoor use, i.e. Class A wheelchairs.

The PRM-TSI specifies the following aspects in relation to the limits in Appendix M:

- level track crossings;
- platform ramps;
- platform lifts;
- universal toilet compartments;
- on-board lifts.

The PRM-TSI specifies other aspects in relation to wheelchairs, but without reference to the limits in Appendix M.

The PRM-TSI does not make any statement concerning access to rail travel for passengers whose wheelchairs have characteristics exceeding the limits specified in Appendix M. In addition, it does not define the term 'wheelchair' and so does not indicate whether scooters used for powered mobility are included within its scope.

#### D.2 Related provisions in this document

Wheelchairs are used in many situations, only some of which will involve travel by rail. Their characteristics are usually determined by the clinical needs and preferences of the occupant. Some wheelchairs will, of necessity, exceed the limits specified in the PRM-TSI. On the other hand, many wheelchair users will want to travel by rail at some point. It would be useful for them to know whether their wheelchair could present difficulties when they are travelling. Therefore, to assist prescribers, purchasers and users of wheelchairs, this document specifies a requirement for disclosure if the wheelchair characteristics exceed the engineering limits specified in the PRM-TSI (see 13.3).

## Annex E (informative)

### Recommendations for safety in freewheel mode

#### E.1 General

Unintentional movement of a wheelchair can occur when it is in freewheel mode on a slope, for example when:

- a) the wheelchair is being pushed down a slope with all driven/braked wheels manually set to freewheel mode and the wheelchair gathers greater speed than intended;
- b) the wheelchair is being driven down a slope and the occupant or assistant manually sets one of the driven/braked wheels to freewheel mode, resulting in the wheelchair deviating from its intended path.

Both situations can be dealt with by manually re-engaging the drive and/or brakes to exit freewheel mode. However, this re-engagement can be dangerous for the occupant or impossible to manage for an elderly assistant, especially if the wheelchair is already moving quickly. Therefore, means should be provided to limit the speed and to allow safe re-engagement.

These means may be provided mechanically or electromechanically. For example, if the controller is operational, the wheelchair is switched on, the motor drive is still engaged and there is sufficient energy in the battery, the control system can actively slow or stop the wheelchair through its normal control function.

If there is no battery power available, the controller is not operational or the wheelchair is switched off, some other means can be implemented to limit the speed to a crawl, such as short-circuiting the drive motors. In this case the speed that results depends on the combined mass of wheelchair and occupant and on the angle of the slope.

To allow for small manoeuvring forces at low speeds (see [ISO 7176-14:2008](#), 8.11, non-powered mobility) the means for limiting speed should only operate once the wheelchair has moved too quickly.

#### E.2 Recommendation

When in freewheel mode, the wheelchair should be prevented from travelling faster than 0,5 m/s on the rated slope.

#### E.3 Recommended test methods

**WARNING — - This testing is potentially hazardous to a human test occupant and other test personnel. Appropriate safety precautions should be taken to avoid injury.**

##### E.3.1 Wheelchair switched on

- a) Place the loaded wheelchair on a test plane inclined at the rated slope.
- b) Switch on the wheelchair.
- c) Operate the freewheel device(s) in accordance with the manufacturer's instructions to enable freewheel mode.

- d) Measure the maximum speed of the wheelchair travelling down the slope.
- e) If the speed travelling down the slope exceeds 0,5 m/s, the wheelchair fails the test.

### **E.3.2 Wheelchair switched off**

Repeat [E.3.1](#) with the wheelchair switched off.

### **E.3.3 Attempted switch-on**

- a) Place the loaded wheelchair on a test plane inclined at the rated slope.
- b) Switch off the wheelchair.
- c) Operate the freewheel device(s) in accordance with the manufacturer's instructions to enable freewheel mode.
- d) After the wheelchair has begun to move, attempt to switch it on.
- e) Measure the maximum speed of the wheelchair travelling down the slope.
- f) If the speed travelling down the slope exceeds 0,5 m/s, the wheelchair fails the test.

### **E.3.4 Battery set disconnected**

- a) Place the loaded wheelchair on a test plane inclined at the rated slope.
- b) Disconnect the battery set.
- c) Operate the freewheel device(s) in accordance with the manufacturer's instructions to enable freewheel mode.
- d) Measure the maximum speed of the wheelchair travelling down the slope.
- e) If the speed travelling down the slope exceeds 0,5 m/s, the wheelchair fails the test.

## Annex F (informative)

### Hazardous substances

#### F.1 Assessment of hazardous substances – General

This annex provides some general guidance to minimize hazardous chemicals in wheelchairs. It is intended to complement legal obligations by providing some practical recommendations keeping in mind, but going beyond, legal minimum requirements.

[F.2](#) focuses on classes of chemicals which are of very high concern from a human health or environmental perspective (CMR, PBT, vPvB, and substances of equivalent concern) which can be found in all materials and products.

[F.3](#) to [F.6](#) contain recommendations for textiles, plastics, metals and wood.

#### F.2 Hazardous substances in all materials or products

##### F.2.1 Substances of very high concern (SVHC) — the European approach on chemicals

###### F.2.1.1 General

In 2006, the new EU regulatory framework concerning the Registration, Evaluation, Authorisation and Restriction of Chemicals (REACH, 1907/2006 [16]) was adopted. REACH requires an authorization for substances of “very high concern” (other substances just require a registration). These are CMR chemicals (carcinogenic, mutagenic and toxic for reproduction), PBTs/vPvBs (persistent, bio accumulating and toxic/very persistent and very bio accumulating substances) and substances identified as causing serious and irreversible effects to humans or the environment equivalent to the effects mentioned on a case-by-case basis. All these substances will be identified in co-operation with the Member States. They are incorporated in a so-called “candidate list” which is published and periodically updated by the European Chemicals Agency (ECHA). Finally, substances requiring authorization will be taken up in Annex XIV of the REACH regulation (1907/2006).

###### F.2.1.2 CMR chemicals

CMR chemicals can belong to one of three different categories. For carcinogenic substances this is described as follows:

- a) Category 1: substances known to be carcinogenic to people. There is sufficient evidence to establish a causal association between human exposure to a substance and the development of cancer.
- b) Category 2: substances which should be regarded as if they are carcinogenic to people. There is sufficient evidence to provide a strong presumption that human exposure to a substance can result in the development of cancer, generally on the basis of:
  - 1) appropriate long-term animal studies;
  - 2) other relevant information.
- c) Category 3: substances which cause concern for people owing to possible carcinogenic effects but in respect of which the available information is not adequate for making a satisfactory assessment. There is some evidence from appropriate animal studies, but this is insufficient to place the substance in Category 2.

For mutagenic substances and substances toxic to reproduction the categories 1, 2 and 3 are described in a similar way (Annex VI of Directive 67/548/EEC [13]).

The applicable risk phrases (R-phrases) for CMR chemicals are listed in [Table F.1](#).

**Table F.1 — R-phrases covering CMR chemicals (Annex VI of Directive 67/548/EEC)**

CARCINOGENIC SUBSTANCES	SUBSTANCES TOXIC FOR REPRODUCTION
R40 Limited evidence of carcinogenic effects (category 3)	R60 May impair fertility (category 1 and 2)
R45 May cause cancer (category 1 and 2)	R61 May cause harm to the unborn child (category 1 and 2)
R49 May cause cancer by inhalation (category 1 and 2)	R62 Possible risk of impaired fertility (category 3)
MUTAGENIC SUBSTANCES	R63 Possible risk of harm to the unborn child (category 3)
R46 May cause heritable genetic damage (category 1 and 2)	
R68 Possible risk of irreversible effects (category 3)	

In 2008, the European Union adopted the “Globally Harmonised System of Classification and Labelling of Chemicals (GHS, 1272/2008 [17]). It will gradually replace the current classification and labelling scheme mentioned above in the forthcoming years.

For CMR chemicals, categories 1, 2 and 3 will be replaced by categories 1A, 1B and 2 with broadly the same meaning. R-phrases will be replaced by new H-phrases.

The applicable Risk phrases (R-phrases) for CMR chemicals are listed in [Table F.2](#).

**Table F.2 — H-phrases covering CMR chemicals (Annex I of Regulation 1272/2008)**

CARCINOGENIC SUBSTANCES	SUBSTANCES TOXIC FOR REPRODUCTION
H350 May cause cancer (category 1A and 1B)	H360 May damage fertility or the unborn child (category 1A and 1B)
H351 Suspected of causing cancer (category 2)	H361 Suspected of damaging fertility or the unborn child (category 2)
MUTAGENIC SUBSTANCES	H362 May cause harm to breast-fed children (additional category for effects on or via lactation)
H340 May cause genetic defects (category 1A and 1B)	
H341 Suspected of causing genetic defects (category 2)	

### F.2.1.3 PBT and vPvB substances

Criteria for the identification of PBT (persistent, bio accumulating and toxic) and vPvB (very persistent and very bio accumulating) substances are included in Annex XIII of the REACH document. A substance that fulfils certain given criteria on persistence, bioaccumulation and toxicity is a PBT substance. A substance that fulfils certain given criteria on persistence and bioaccumulation is a vPvB substance.

### F.2.1.4 Substances of equivalent concern

Substances such as those having endocrine disrupting properties or those having persistent, bio accumulative and toxic properties or very persistent and very bio accumulative properties, which do not fulfil the criteria set out in Annex XIII for which there is scientific evidence of probable serious effects to human health or the environment which give rise to an equivalent level of concern as CMR, PBT and vPvB substances are identified on a case-by-case basis.

## F.2.2 Recommendations

### F.2.2.1 General

Whilst the implementation of REACH including the authorization of SVHS will take many years, it is advisable, as a matter of prudence, to eliminate such substances wherever possible as soon as practicable. Safety data sheets of substances used in the production of assistive products will provide the necessary information. It is also recommended to regularly check the "candidate list" on the website of ECHA to identify any new entry: <https://echa.europa.eu/candidate-list-table>.

### F.2.2.2 CMR chemicals

It is proposed to avoid CMR chemicals from all three categories. A threshold of 0,1 % by weight can be used here as a starting point. However, some CMR substances are of concern at much lower levels. It is therefore recommended to reduce the levels of CMR substances as far as technically feasible using a precautionary approach.

### F.2.2.3 PBT and vPvB substances

The product should not contain any PBT and vPvB substances based on the criteria listed in Annex XIII of REACH in amounts exceeding 0,1 % by weight.

### F.2.2.4 Substances of equivalent concern

As these substances are identified on a case-by-case basis it is recommended to avoid using substances once included in the candidate list in amounts exceeding 0,1 % by weight unless lower levels seem to be warranted.

## F.3 Hazardous substances in textiles

### F.3.1 Relevant substances

For textiles, several ecolabel criteria exist at European and national levels that should be considered when establishing requirements for textile components of assistive products for persons with disability.

The Oeko-Tex Standard 100 [23] for textile end products has received broad recognition on the marketplace as representing the state-of-the-art. About 5000 companies in the world have an Oeko-Tex Standard 100 label which makes it the most widespread label of all textile eco-labels.

Limit values are included for:

- formaldehyde;
- heavy metals;
- pesticides;
- chlorinated phenols;
- phthalates;
- organic tin compounds;
- other chemical residues;
- colorants;
- chlorinated benzenes and toluenes;
- biological active products;

- flame retardant products;
- colour fastness;
- emission of volatiles;
- odours.

The Oeko-Tex Association has developed different criteria for textile products for babies, for products with and without direct skin contact and for decoration materials. More details can be found on the website: <http://www.oeko-tex.com>.

### F.3.2 Recommendations

Textile products or components should comply with the relevant requirements of Oeko-Tex Standard 100. Other ecolabels can contain more ambitious requirements (e.g. for organic textiles) and should be also considered.

## F.4 Hazardous substances in plastic materials

### F.4.1 Relevant substances

Various national and European specifications contain criteria for plastic materials or components which can be taken as a basis when establishing requirements for plastic components of assistive products for persons with a disability. Key criteria include:

- substances based on lead, cadmium, mercury and their compounds;
- halogenated organic materials;
- phthalates.

### F.4.2 Recommendations

#### F.4.2.1 Substances based on lead, cadmium, mercury and their compounds or tin organic compounds

The European Council Directive on packaging and packaging waste (94/62/EC [14]) has set a limit of 100 ppm for the sum of lead, cadmium, mercury and hexavalent chromium in plastic packaging. In order to set a limit to heavy metal content of plastic used in assistive products for persons with a disability, it is proposed to comply with the limit as used in the European Packaging Directive.

#### F.4.2.2 Organic halogenated compounds

Organic halogenated compounds as flame retardants can be added to plastic parts. Some of the halogenated flame retardants show hazardous impacts to health and environment, are persistent and bio-accumulative.

Polybrominated biphenyls (PBB), polybrominated diphenylether (PBDE) and short-chained chloroparaffins (all are organic halogenated compounds) can be added to plastic part(s). PBB and PBDE belong to the group of brominated flame retardants and show hazardous effects on health and the environment. Many chlorinated paraffins are persistent and bio accumulative. It is recommended to avoid the use of PBBs, PBDEs or chlorinated paraffin.

#### F.4.2.3 Phthalates

These substances are used as plasticizers in PVC and can have reprotoxic effects. It is therefore preferable to exclude phthalates. For medical devices, there are alternatives for phthalates on the market. However, phthalate substitutes can reduce the functionality of the device or, when used in



blood bags, can have health impacts on patients. It is therefore proposed that plastic parts of assistive products for persons with a disability should not contain phthalates in quantities higher than 0,1 ppm unless there is evidence that phthalates are necessary on technical grounds and cannot be substituted by other plasticizers or the product cannot be produced using other plastic materials.

## **F.5 Metals**

### **F.5.1 Relevant substances**

Of particular importance are criteria for metal coatings and plating:

- cadmium;
- chromium;
- nickel

and their compounds. Such coatings are necessary only where heavy physical wear can be anticipated or in the case of parts that require particularly tight connections. For parts that are intended to come into frequent contact with skin, such coatings should be avoided. Cadmium should not be used at all.

### **F.5.2 Recommendations**

Metal parts should not be coated with cadmium, chromium, nickel and their compounds. In exceptional cases, metal surfaces may be treated with chromium or nickel where this is necessary on the grounds of heavy physical wear or in the case of parts that require particularly tight connections. This exemption does not include parts that are intended to come into frequent contact with skin and the treated parts should be recyclable.

## **F.6 Wood**

### **F.6.1 Relevant substances**

Various national and European specifications contain criteria for formaldehyde, an irritating and carcinogenic substance, in wood-based panels.

### **F.6.2 Recommendations**

One of the two following requirements should be fulfilled:

- a) The content of free formaldehyde measured in accordance with EN ISO 12460-5 should be:
  - 1) Single values:  $\leq 8$  mg formaldehyde per 100 g product;
  - 2) Half year mean value:  $\leq 6,5$  mg formaldehyde per 100 g product.
- b) Formaldehyde emission measured in a test chamber in accordance with [EN 717-1](#) should be less than 0,13 mg formaldehyde per m<sup>3</sup> air.

## Annex G (normative)

### Applicable provisions for particular types of wheelchair

#### G.1 General

This annex specifies the application of provisions in this document to the following types of wheelchair:

- manual wheelchairs with an add-on electrically powered drive system;
- manual wheelchairs with electrically powered ancillary equipment;
- handrim-activated power-assisted wheelchairs (HAPAWs);
- stand-up wheelchairs (SUWs);
- wheelchairs with a pivot drive wheel unit (PDWs);
- push-assist wheelchairs (PAWs).

The following subclauses specify the provisions applicable to each type.

Wheelchairs which are within the scope of this document but not included in this annex are covered by the main body of the text.

#### G.2 Manual wheelchairs with an add-on electrically powered drive system

The combination of a manual wheelchair and an add-on electrically powered drive system is an electrically powered wheelchair. In the case that the manual wheelchair can be used separately from the add-on drive system, [EN 12183:2022](#) can also apply. See [EN 12183:2022](#), Clause 1.

Where the combination of the manual wheelchair and add-on drive system is a type of wheelchair covered by one of the following subclauses of this annex, that subclause applies.

EXAMPLE [G.4](#) applies to a HAPAW comprising a manual wheelchair and an add-on electrically powered drive system.

Where the combination of the manual wheelchair and add-on drive system is a wheelchair within the scope of this document but not covered by this annex, then it is covered by the main body of the text.

#### G.3 Manual wheelchairs with electrically powered ancillary equipment

Where a manual wheelchair has electrically powered ancillary equipment that can move parts of the body support system, the electrically powered ancillary equipment shall meet the applicable requirements of [Clause 12](#).

#### G.4 HAPAWs

##### G.4.1 General

Where a HAPAW can only be used with powered assistance, the main body of this document applies, instead of this annex.

Where a HAPAW can be used with and without powered assistance, [G.4.2](#), [G.4.3](#) and [G.4.4](#) apply.

#### **G.4.2 Use as a manual wheelchair**

[EN 12183:2022](#) applies, with the following modifications.

*7.1.1 is replaced by the following:*

If the static stability of the wheelchair in the rearward direction is less than 10°, the wheelchair shall be fitted with anti-tip devices that increase the static stability in the rearward direction to at least 10°.

*The second paragraph of 7.1.2 is deleted.*

#### **G.4.3 Use with powered assistance**

The subclauses in this document identified by A or M in [Table G.1](#) for HAPAWs apply in addition to the requirements of [G.4.2](#). The modifications to the subclauses identified by M in [Table G.1](#) are as follows:

*8.1.8 is replaced by the following:*

The wheelchair shall not provide powered assistance at speeds greater than 6 km/h

*10.3 The introductory phrase is replaced by the following:*

Where the wheelchair has a parking brake that depends on electrical power to release, the wheelchair shall have a freewheel device that shall

*12.1 The first paragraph is replaced by the following:*

The wheelchair shall conform to the requirements of [ISO 7176-14:2008](#), except as specified in [9.5.3](#) and [G.4.4](#).

*12.1 The note is replaced by the following:*

NOTE [ISO 7176-21:2009](#) does not specify radiated emissions tests for movement of parts of the body support system or suitable equipment for maintaining wheel speed during driving tests.

*13.2 d), g), k) and l) are deleted.*

*13.3 e) is replaced by the following:*

instructions on how to engage and disengage the drive system, where applicable;

*13.3 w) is deleted.*

*13.5 b) is replaced by the following:*

devices for disengagement of the drive system, showing engaged and disengaged positions, where applicable;

*13.5 e) is deleted.*

#### **G.4.4 Power and control systems**

For HAPAWs which can be used both with and without powered assistance, the following modifications are made to [ISO 7176-14:2008](#):

*7.4, 8.11, 8.13 and 10.7 are deleted.*

*8.2.2 The text “shall” is replaced by “should”.*

*8.5.1 and 8.5.2.1 The text “visual and auditory” is replaced by “visual or auditory”.*

*8.8 is replaced by the following:*

The wheelchair should provide an indication to the operator that the battery set is nearing depletion.

**Table G.1 — Applicable provisions**

Clause reference	HAPAW (see G.4.3)	SUW (see G.5.2)	PDW (see G.6.2)	PAW (see G.7)
5				
6	A	A	A	A
7	A	M	A	A
<a href="#">8.1.1</a>				
<a href="#">8.1.2</a>				
<a href="#">8.1.3</a>				
<a href="#">8.1.4</a>				
<a href="#">8.1.5</a>				M
<a href="#">8.1.6</a>				
<a href="#">8.1.7</a>		M		
<a href="#">8.1.8</a>	M		M	M
<a href="#">8.1.9</a>				
<a href="#">8.2</a>		M	A	A
<a href="#">8.3</a>			A	A
<a href="#">8.4</a>	A		A	A
<a href="#">9.1</a>		M	A	A
<a href="#">9.2</a>			A	A
<a href="#">9.3</a>			A	A
<a href="#">9.4</a>		M	A	A
<a href="#">9.5</a>			A	A
<a href="#">10.1</a>		M	A	A
<a href="#">10.2</a>		M	A	M
<a href="#">10.3</a>	M	A	A	M
<a href="#">11.1</a>	A	A	A	A
<a href="#">11.2</a>	A		A	A
<a href="#">11.3</a>			A	A
<a href="#">11.4</a>			A	A
<a href="#">11.5</a>		A		
<a href="#">11.6</a>			A	
<a href="#">12.1</a>	M		A	A
<a href="#">12.2</a>	A		A	A
<a href="#">12.3</a>	A		A	A
<a href="#">12.4</a>	A		A	A
<a href="#">12.5</a>	A		A	A
<a href="#">12.6</a>			A	A
<a href="#">12.7</a>			A	A
<a href="#">12.8</a>			A	A
<a href="#">12.9</a>	A		A	A
<a href="#">12.10</a>	A		A	A
<a href="#">12.11</a>	A		A	A
<a href="#">13.1</a>	A		A	A

<http://www.china-gauges.com/>

Clause reference	HAPAW (see <a href="#">G.4.3</a> )	SUW (see <a href="#">G.5.2</a> )	PDW (see <a href="#">G.6.2</a> )	PAW (see <a href="#">G.7</a> )
<a href="#">13.2</a>	M		M	M
<a href="#">13.3</a>	M		A	A
<a href="#">13.4</a>	A		A	
<a href="#">13.5</a>	M		M	M
14	A			A
<a href="#">Annex A</a>			A	A
<a href="#">B.1</a>			A	A
<a href="#">B.2</a>			A	A
<a href="#">B.3.1</a>			A	A
<a href="#">B.3.2</a>	A		A	A
<a href="#">B.3.3</a>	A		A	A
<a href="#">B.3.4</a>	A		A	A
<a href="#">B.3.5</a>				
<a href="#">Annex C</a>			A	A
<a href="#">Annex E</a>			A	A
<a href="#">Annex F</a>	A		A	A
<b>Key</b>				
A provisions are applied without modification				
M modified provisions are applied as specified in the text				

## G.5 Stand-up wheelchairs

### G.5.1 General

For a stand-up wheelchair in a sitting configuration, the main body of this document applies, instead of this annex.

In addition, for a stand-up wheelchair in a standing configuration, [G.5.2](#) applies.

### G.5.2 Applicable provisions for standing configuration

The subclauses in this document identified by A or M in [Table G.1](#) for SUWs apply. The modifications to the subclauses identified by M in [Table G.1](#) are as follows:

*7.1 In the first paragraph, the word “modification” is replaced with “modifications”.*

*7.1 The following is prepended to the second paragraph:*

Set the body support system for a standing posture in accordance with the manufacturer’s instructions.

*7.2 The following is appended to the second paragraph:*

Where necessary, lock the hip, knee and/or ankle joints of the test dummy (See [ISO 7176-11:2012](#), 7.7).

*8.1.7.1 is replaced by the following:*

The static stability of the wheelchair shall not be less than:

- 7° in the forward and rearward directions and 5° in the lateral directions; or
- the rated slope specified by the manufacturer, if it is greater.

8.1.7.2 is replaced by the following:

Test the loaded wheelchair in the least-stable standing configuration for each direction as specified in [ISO 7176-1:2014](#) to determine whether it meets the requirements in [8.1.7.1](#).

8.2.2 is replaced by the following:

If the wheelchair can be manoeuvred in the standing configuration, adjust the body support system for the standing configuration, fit the test dummy and subject the wheelchair to a fatigue test of 20 000 cycles on the multi-drum tester in accordance with [ISO 7176-8:2014](#).

If the wheelchair can be manoeuvred in an intermediate configuration between the sitting and standing configurations, adjust the body support system to the closest intermediate configuration to the sitting configuration, fit the test dummy and subject the wheelchair to a fatigue test of 20 000 cycles on the multi-drum tester in accordance with [ISO 7176-8:2014](#).

The number of test cycles of the fatigue test for the wheelchair in the sitting configuration may be reduced correspondingly to give the same total.

9.1 d) is deleted.

9.4 The text "sitting" is replaced by "standing", the text "forwards" is replaced by "forwards or downwards" and the text "the wheelchair is decelerating" is replaced by "the occupant is standing and/or the wheelchair is decelerating".

10.1.1 a) 2) and 3) are deleted.

10.2.1 j) is deleted.

10.2.2.3 is deleted.

## G.6 Wheelchairs with pivot drive wheel units

### G.6.1 General

Where a wheelchair with a pivot drive wheel unit can operate without the occupant providing some of the power needed for propulsion, the main body of this document applies, instead of this annex.

In addition, where a wheelchair with a pivot drive wheel unit can operate with the occupant providing some of the power needed for propulsion, [G.6.2](#) and [G.6.3](#) apply.

### G.6.2 Applicable provisions

The subclauses in this document identified by A or M in [Table G.1](#) for PDWs apply. The modifications to the subclauses identified by M in [Table G.1](#) are as follows:

8.1.8 is replaced by the following:

The wheelchair shall not provide powered assistance at speeds greater than 20 km/h

13.2 d), g), k) and l) are deleted.

13.5 e) is deleted.

### G.6.3 Applicable provisions of EN 15194:2017

The subclauses of [EN 15194:2017](#) identified by A or M in [Table G.2](#) apply. The modifications identified by M in [Table G.2](#) are as follows:

3.1 and 3.2 The definitions are replaced by the following:

wheelchair with a pivot drive wheel unit that is propelled partly by the muscular energy of the occupant

**Table G.2 — PDWs - applicable provisions of EN 15194:2017**

Clause reference	Application of provisions (see <a href="#">G.6.3</a> )
3	M
4.2.5	
4.2.6	A
4.2.7	A
4.2.13	A
<b>Key</b>	
A	provisions are applied without modification
M	modified provisions are applied as specified in the text

## G.7 Push-assist wheelchairs

The subclauses in this document identified by A or M in [Table G.1](#) for PAWs apply. The modifications to the subclauses identified by M in [Table G.1](#) are as follows:

*8.1.5 is replaced by the following:*

Anti-tip devices shall be fitted to the wheelchair.

*8.1.8 is replaced by the following:*

The wheelchair shall not provide powered assistance at speeds greater than 6 km/h

*10.2.1 b) is replaced by the following:*

Where the wheelchair has a freewheel device, the wheelchair shall have a running brake which, when operated after the wheelchair has been put into freewheel mode, shall bring the wheelchair to a stop (See [10.3](#)).

*10.3 The introductory phrase is replaced by the following:*

Where the wheelchair has a parking brake that depends on electrical power to release, the wheelchair shall have a freewheel device that shall

*13.2 d), g), k) and l) are deleted.*

*13.5 b) is replaced by the following:*

devices for disengagement of the drive system, showing engaged and disengaged positions, where applicable;

*13.5 e) is deleted.*

## Annex H (informative)

### Technical changes from the previous edition of EN 12184

The list below includes the significant technical changes between the fourth (2014) and fifth editions, but it does not include all changes. References to elements of the text apply to the fourth edition.

- The status of wheelchairs to which the previous edition partially applied has been clarified.
- A minimum occupant mass is specified in the scope, due to the lower mass limit of [ISO 7176-11](#).
- The scope now includes wheelchairs with a maximum speed up to 20 km/h.
- The list of normative references has been updated.
- Test plane specifications have been modified to allow for testing of high-speed wheelchairs.
- Requirements for risk management have been modified.
- The referenced content of [EN 12182:2012](#) has been transposed into the document, and modified where appropriate to make the content specific to wheelchairs.
- A requirement that the rated slope is not less than the specified minimum has been added.
- Dynamic stability testing is required only at the rated slope.
- For rearward dynamic stability and rearward static stability, additional testing with a 100 kg dummy is required where the maximum occupant mass is greater.
- Modifications to [ISO 7176-8](#) testing for occupant masses above 100 kg have been deleted.
- Requirements for wheelchairs used as seats in motor vehicles have been modified.
- The requirements and test method for gaps between foot supports have been modified.
- Requirements for an anterior pelvic support have been modified.
- Requirements for resistance to ignition have been modified.
- The risk management process now has to address loss of braking due to wheel lift.
- The applicability of [ISO 7176-21](#) to moving parts of the body support system has been clarified.
- Requirements for circuit protection have been modified.
- [ISO 7176-25](#) is now applied to battery chargers.
- The electrical safety requirements of [EN 60601-1](#) are allowed as an alternative to the electrical safety requirements of [EN 60335-2-29](#).
- Transitional provisions for application of EN 62304 have been removed.
- Requirements for lithium cells and batteries have been added.
- Requirements for remote control have been added.
- Requirements for user information have been modified.



- [Table 3](#) has been deleted.
- Recommendations for wheelchairs with cabins or covers have been added to [Annex B](#).
- [Annex D](#) has been updated.
- A new annex concerning requirements for particular types of wheelchair has been added.

<http://www.china-gauges.com/>

## Bibliography

- [1] [EN 716-2:2017](#), *Furniture - Children's cots and folding cots for domestic use - Part 2: Test methods*
- [2] [EN 717-1](#), *Wood-based panels - Determination of formaldehyde release - Part 1: Formaldehyde emission by the chamber method*
- [3] [EN 894-3](#), *Safety of machinery - Ergonomics requirements for the design of displays and control actuators - Part 3: Control actuators*
- [4] [EN 1888-1](#), *Child care articles - Wheeled child conveyances - Part 1: Pushchairs and prams*
- [5] [ISO 68-1](#), *ISO general purpose screw threads - Basic profile — Part 1: Metric screw threads*
- [6] [ISO 7176-5](#), *Wheelchairs — Part 5: Determination of dimensions, mass and manoeuvring space*
- [7] [ISO 7176-7:1998](#), *Wheelchairs — Part 7: Measurement of seating and wheel dimensions*
- [8] [ISO 7193](#), *Wheelchairs — Maximum overall dimensions*
- [9] [EN ISO 12460-5](#), *Wood-based panels - Determination of formaldehyde release - Part 5: Extraction method (called the perforator method) (ISO 12460-5)*
- [10] [ISO 16840-3](#), *Wheelchair seating — Part 3: Determination of static, impact and repetitive load strengths for postural support devices*
- [11] Regulation No 48 of the Economic Commission for Europe of the United Nations (UN/ECE), *Uniform provisions concerning the approval of vehicles with regard to the installation of lighting and light-signalling devices*. Available at <https://op.europa.eu/s/uqQR>
- [12] COST 335, *Passengers' Accessibility of Heavy Rail Systems, Final Report of the Action*. Available at <https://op.europa.eu/s/tOfB>
- [13] Official Journal of the European Union, *Council Directive 67/548/EEC of 27 June 1967 on the approximation of laws, regulations and administrative provisions relating to the classification, packaging and labelling of dangerous substances*. Available at <https://data.europa.eu/eli/dir/1967/548/oj>
- [14] Official Journal of the European Union, *European Parliament and Council Directive 94/62/EC of 20 December 1994 on packaging and packaging waste*. Available at <https://data.europa.eu/eli/dir/1994/62/oj>
- [15] Official Journal of the European Union, *Directive 2006/42/EC of the European Parliament and of the Council of 17 May 2006 on machinery, and amending Directive 95/16/EC (recast)*. Available at <https://data.europa.eu/eli/dir/2006/42/oj>
- [16] Official Journal of the European Union, *Regulation (EC) No 1907/2006 of the European Parliament and of the Council of 18 December 2006 concerning the Registration, Evaluation, Authorisation and Restriction of Chemicals (REACH)*. Available at <https://data.europa.eu/eli/reg/2006/1907/oj>
- [17] Official Journal of the European Union, *Regulation (EC) No 1272/2008 of the European Parliament and of the Council of 16 December 2008 on classification, labelling and packaging of substances and mixtures, amending and repealing Directives 67/548/EEC and 1999/45/EC, and amending Regulation (EC) No 1907/2006*. Available at <https://data.europa.eu/eli/reg/2008/1272/oj>

[18] Official Journal of the European Union, *Regulation (EC) No 661/2009 of the European Parliament and of the Council of 13 July 2009 concerning type-approval requirements for the general safety of motor vehicles, their trailers and systems, components and separate technical units intended therefor*. Available at <https://data.europa.eu/eli/reg/2009/061/oj>

[19] Official Journal of the European Union, *Commission Regulation (EU) No 1300/2014 of 18 November 2014 on the technical specifications for interoperability relating to accessibility of the Union's rail system for persons with disabilities and persons with reduced mobility*. Available at <https://data.europa.eu/eli/reg/2014/1300/oj>

[20] Official Journal of the European Union, *Directive 2016/797 of the European Parliament and of the Council of 11 May 2016 on the interoperability of the rail system within the Community (Recast)*. Available at <https://data.europa.eu/eli/dir/2016/797/oj>

[21] Official Journal of the European Union, *Regulation (EU) 2017/745 of the European Parliament and of the Council of 5 April 2017 on medical devices*. Available at <https://data.europa.eu/eli/reg/2017/745/oj>

[22] MEDDEV 2.7/1 revision 4, *Clinical Evaluation: A guide for manufacturers and notified bodies under Directives 93/42/EEC and 90/385/EEC*. Available at <http://ec.europa.eu>

[23] Oeko-Tex Standard 100. Available at <http://www.oeko-tex.com>

# British Standards Institution (BSI)

BSI is the national body responsible for preparing British Standards and other standards-related publications, information and services.

BSI is incorporated by Royal Charter. British Standards and other standardization products are published by BSI Standards Limited.

## About us

We bring together business, industry, government, consumers, innovators and others to shape their combined experience and expertise into standards-based solutions.

The knowledge embodied in our standards has been carefully assembled in a dependable format and refined through our open consultation process. Organizations of all sizes and across all sectors choose standards to help them achieve their goals.

## Information on standards

We can provide you with the knowledge that your organization needs to succeed. Find out more about British Standards by visiting our website at [bsigroup.com/standards](http://bsigroup.com/standards) or contacting our Customer Services team or Knowledge Centre.

## Buying standards

You can buy and download PDF versions of BSI publications, including British and adopted European and international standards, through our website at [bsigroup.com/shop](http://bsigroup.com/shop), where hard copies can also be purchased.

If you need international and foreign standards from other Standards Development Organizations, hard copies can be ordered from our Customer Services team.

## Copyright in BSI publications

All the content in BSI publications, including British Standards, is the property of and copyrighted by BSI or some person or entity that owns copyright in the information used (such as the international standardization bodies) and has formally licensed such information to BSI for commercial publication and use.

Save for the provisions below, you may not transfer, share or disseminate any portion of the standard to any other person. You may not adapt, distribute, commercially exploit or publicly display the standard or any portion thereof in any manner whatsoever without BSI's prior written consent.

## Storing and using standards

Standards purchased in soft copy format:

- A British Standard purchased in soft copy format is licensed to a sole named user for personal or internal company use only.
- The standard may be stored on more than one device provided that it is accessible by the sole named user only and that only one copy is accessed at any one time.
- A single paper copy may be printed for personal or internal company use only.

Standards purchased in hard copy format:

- A British Standard purchased in hard copy format is for personal or internal company use only.
- It may not be further reproduced – in any format – to create an additional copy. This includes scanning of the document.

If you need more than one copy of the document, or if you wish to share the document on an internal network, you can save money by choosing a subscription product (see 'Subscriptions').

## Reproducing extracts

For permission to reproduce content from BSI publications contact the BSI Copyright and Licensing team.

## Subscriptions

Our range of subscription services are designed to make using standards easier for you. For further information on our subscription products go to [bsigroup.com/subscriptions](http://bsigroup.com/subscriptions).

With **British Standards Online (BSOL)** you'll have instant access to over 55,000 British and adopted European and international standards from your desktop. It's available 24/7 and is refreshed daily so you'll always be up to date.

You can keep in touch with standards developments and receive substantial discounts on the purchase price of standards, both in single copy and subscription format, by becoming a **BSI Subscribing Member**.

**PLUS** is an updating service exclusive to BSI Subscribing Members. You will automatically receive the latest hard copy of your standards when they're revised or replaced.

To find out more about becoming a BSI Subscribing Member and the benefits of membership, please visit [bsigroup.com/shop](http://bsigroup.com/shop).

With a **Multi-User Network Licence (MUNL)** you are able to host standards publications on your intranet. Licences can cover as few or as many users as you wish. With updates supplied as soon as they're available, you can be sure your documentation is current. For further information, email [cservices@bsigroup.com](mailto:cservices@bsigroup.com).

## Revisions

Our British Standards and other publications are updated by amendment or revision.

We continually improve the quality of our products and services to benefit your business. If you find an inaccuracy or ambiguity within a British Standard or other BSI publication please inform the Knowledge Centre.

## Useful Contacts

### Customer Services

**Tel:** +44 345 086 9001

**Email:** [cservices@bsigroup.com](mailto:cservices@bsigroup.com)

### Subscriptions

**Tel:** +44 345 086 9001

**Email:** [subscriptions@bsigroup.com](mailto:subscriptions@bsigroup.com)

### Knowledge Centre

**Tel:** +44 20 8996 7004

**Email:** [knowledgecentre@bsigroup.com](mailto:knowledgecentre@bsigroup.com)

### Copyright & Licensing

**Tel:** +44 20 8996 7070

**Email:** [copyright@bsigroup.com](mailto:copyright@bsigroup.com)

## BSI Group Headquarters

389 Chiswick High Road London W4 4AL UK