

C22.2 No. 46-M1988 (Reaffirmed 2001)
(Reaffirmed 1996)

Electric Air-Heaters

Environmental Products

<http://www.china-gauges.com/>

General Instruction No. 1

C22.2 No. 46-M1988
November 1988

<http://www.china-gauges.com/>

CSA Standard C22.2 No. 46-M1988, *Electric Air-Heaters*, consists of **73** pages, each dated **November 1988**.

This Standard, like all CSA Standards, is subject to periodic review, and amendments in the form of replacement pages may be issued from time to time; such pages will be mailed automatically to those purchasers who complete and return the attached card.* Some Standards require frequent revision between editions, whereas others require none at all. It is planned to issue new editions of the Standard, regardless of the amount of revision, at intervals not greater than 5 years. Except in unusual circumstances, replacement pages will not be issued during the last year of that edition.

**This card will appear with General Instruction No. 1 only.*

Although any replacement pages that have been issued will be sold with the Standard, it is for the purchaser to insert them where they apply. The responsibility for ensuring that his or her copy is complete rests with the holder of the Standard, who should, for the sake of reference, retain those pages which have been replaced.

Note: *A General Instruction sheet will accompany replacement pages each time they are issued and will list the latest date of each page of the Standard.*

Cut along dotted line.

Name _____

Organization _____

Address _____

City _____

Prov./State _____

Country _____

Postal/Zip Code _____

**CSA Standard
C22.2 No. 46-M1988**

<http://www.china-gauges.com/>

Place
Stamp
Here

Canadian Standards Association
Consolidated Mailing List
178 Rexdale Boulevard
Rexdale (Toronto), Ontario
Canada
M9W 1R3



C22.2 No. 46-M1988
Electric Air-Heaters

Environmental Products

<http://www.china-gauges.com/>



ISSN 0317-5669
Published in November 1988
by
Canadian Standards Association
(Incorporated 1919)
178 Rexdale Boulevard
Rexdale (Toronto), Ontario
Canada
M9W 1R3

<http://www.china-gauges.com/>

Technical Editor: Richard D. Cohen

Managing Editor: Bernard Kelly

© Canadian Standards Association—1988

All rights reserved. No part of this publication may be reproduced in any form, in an electronic retrieval system or otherwise, without the prior permission of the publisher.

Contents

Technical Committee on Environmental Products	5
Subcommittee on C22.2 No. 46	6
Preface	7
Foreword	8
1. Scope	11
2. Definitions	11
3. General Requirements	12
3.1 General	12
3.2 Reference Publications	12
4. Construction	16
4.1 General	16
4.2 Enclosures for Live Parts	16
4.3 Protection Against Corrosion	22
4.4 Mechanical Assembly	22
4.5 Receptacles	23
4.6 Supply Connections	23
4.6.1 Permanently Connected Heaters	23
4.6.2 Portable Heaters	25
4.6.3 Terminal Parts	25
4.6.4 Strain Relief	26
4.7 Electrical Insulation	27
4.8 Thermal Insulation	27
4.9 Current-Carrying Parts	28
4.10 Wiring	28
4.11 Heating and Heater Elements	28
4.12 Protection Against Overheating	30
4.13 Lampholders and Lamps	32
4.14 Switches and Controls	34
4.15 Overcurrent Protection	34
4.16 Motors	34
4.17 Suppressors	35
4.18 Spacings	35
4.19 Grounding and Bonding	35
4.20 Stability	36
4.21 Stand-Off Guards for Cord-Connected Radiant Heaters	36
5. Marking	36
6. Tests	41
6.1 General	41
6.2 Rating	42
6.3 Test Voltage	42
6.4 Temperature (Normal)	42
6.5 Dielectric Strength	47
6.6 Temperature (Abnormal)	48
6.7 Extreme Operating Voltage (Maximum) Test	53
6.8 Strain Relief	53

6.9	Overload and Endurance--Manually Operated Switches	54
6.10	Performance of Fusible Links	55
6.11	Physical Abuse Tests	55
6.12	Flame Test for Nonmetallic Enclosures and Supports	56
6.13	Leakage Current	57
6.14	Performance of Thermally Operated Controls	58
6.14.1	General	58
6.14.2	Calibration	58
6.14.3	Overload	58
6.14.4	Endurance	59
6.14.5	Conditioning and Recalibration (Temperature Limiting Thermostats for Stationary Baseboard Heaters)	59
6.15	Performance of Heaters Having PTC Heater Elements	59
6.15.1	General	59
6.15.2	Thermal Cycling	60
6.15.3	Humidity Conditioning	60
6.15.4	Low Temperature Cycling	60
6.15.5	Heat-Cold Conditioning	60
6.15.6	Vibration	61
6.16	Hydrostatic Test	61
6.17	Dropping Melted Particles Test	61
6.18	Stability	62

7. Requirements for Cord-Connected Double-Insulated Electric Air-Heaters 62

7.1	Scope	62
7.2	Definitions	62
7.3	General Requirements	63
7.4	Construction	63
7.4.1	General	63
7.4.2	Openings and Recesses	64
7.4.3	Mechanical Assembly	65
7.4.4	Supply Connections	65
7.4.5	Spacings	66
7.5	Marking	66
7.6	Tests	66
7.6.1	Dielectric Strength	66
7.6.2	Leakage Current	66
7.6.3	Abnormal Operation	67

Tables 67

Figures 73

Technical Committee on Environmental Products

D.H. Dunsire Manitoba Hydro, Chairman
Winnipeg
Representing Regulatory Authorities

R.L. Hicks Ontario Hydro, Vice-Chairman
Toronto
Representing Regulatory Authorities

R.D. Cohen Canadian Standards Association, Standards
Rexdale, Ontario Administrator,
Nonvoting

Representing Regulatory Authorities

D.G. Harley The City of Calgary Electric System,
Calgary, Alberta

M. Riendeau Ministère du Travail,
Montreal, Québec

Representing Manufacturers

B.C. Christie Manville Canada Inc.,
Brampton, Ontario

N. Hendrycks Chromalox Incorporated,
Rexdale, Ontario

G. F. Longmuir Commander Electrical Equipment Inc.,
Scarborough, Ontario

B.I. Sormon Trane Canada,
Toronto, Ontario

B.N. Taylor Honeywell Limited,
Scarborough, Ontario

Representing General Interests

R.L. Cane Ontario Research Foundation,
Mississauga, Ontario
Consumer Representative

R.E. Dowling Canadian Standards Association, Alternate
Rexdale, Ontario

W.J. Heeley Heating, Refrigerating and Air
Conditioning Institute of Canada,
Islington, Ontario

R.H. Smith Canadian Standards Association,
Rexdale, Ontario

Subcommittee on C22.2 No. 46

N. Hendrycks	Chromalox Incorporated, Rexdale, Ontario	Chairman
A. Thomas	Air-King Ltd., Brampton, Ontario	Vice-Chairman
R. Beaulieu	Ouellet Canada Inc., Ville de l'Islet, Québec	
E.C. Goudge	Commander Electrical Equipment Inc., Scarborough, Ontario	
R. Hart	Heron Cable Industries Limited, Waterloo, Ontario	
H.W. Hayes	Westcan Electric Heating Inc., Toronto, Ontario	
P. Kundlacz	Black & Decker Canada Inc., Brockville, Ontario	
D. Page	Superior Electric Limited, Pembroke, Ontario	
J. Pallas	Standard Appliance Mfg. Co. Limited, Toronto, Ontario	
R. Quimper	Ministère du Travail, Québec, Québec	
W. Ridgeway	Air-King Limited, Brampton, Ontario	
R. Schaefer	Budd Canada Inc., Winnipeg, Manitoba	
V. Toews	Department of Community and Transportation Services, Whitehorse, Yukon	
G. Young	Canadian Standards Association, Rexdale, Ontario	
R.D. Cohen	Canadian Standards Association, Rexdale, Ontario	Standards Administrator

Preface

This is the eighth edition of C22.2 No. 46 of a series of Standards issued by the Canadian Standards Association under Part II of the *Canadian Electrical Code*. It is written in metric (SI) units. It supersedes previous editions published in 1981, 1980, 1971, 1966, 1959, 1942, and 1938.

This edition mainly serves to update the 1981 edition with a view to improving the safety of stationary electric baseboard heaters.

For general information on the Standards of the *Canadian Electrical Code, Part II*, see the preface of CSA Standard C22.2 No. 0, *General Requirements-Canadian Electrical Code, Part II*.

This Standard was prepared by a Subcommittee of the Technical Committee on Environmental Products under the jurisdiction of the Standards Steering Committee on Canadian Electrical Code, Part II, and was formally approved by these Committees.

November 1988

Notes:

- (1) Use of the masculine gender in this Standard is not meant to exclude the feminine gender when applied to persons. Similarly, use of the singular does not exclude the plural (and vice versa) when the sense allows.
- (2) Although the intended primary application of this Standard is stated in its Scope, it is important to note that it remains the responsibility of the user of the Standard to judge its suitability for his particular purpose.
- (3) CSA Standards are subject to periodic review, and suggestions for their improvement will be referred to the appropriate committee.
- (4) All enquiries regarding this Standard, including requests for interpretation, should be addressed to Canadian Standards Association, Standards Division, 178 Rexdale Boulevard, Rexdale, Ontario M9W 1R3.

Requests for interpretation should

- (a) define the problem, making reference to the specific clause, and, where appropriate, include an illustrative sketch;
- (b) provide an explanation of circumstances surrounding the actual field condition; and
- (c) be phrased where possible to permit a specific "yes" or "no" answer.

Interpretations are published in CSA Information Update. For subscription details and a free sample copy, write to CSA Marketing or telephone (416) 747-4019.

Foreword

Canadian Standards Association provides certification services for manufacturers who, under license from CSA, wish to use the appropriate registered CSA Marks on certain products of their manufacture to indicate conformity with CSA Standards.

CSA Certification for a number of products is provided in the interest of maintaining agreed-upon standards of quality, performance, interchangeability and/or safety, as appropriate. Where applicable, certification may form the basis for acceptance by inspection authorities responsible for enforcement of regulations. Where feasible, programs will be developed for additional products for which certification is desired by producers, consumers or other interests.

In performing its functions in accordance with its objectives, CSA does not assume or undertake to discharge any responsibility of the manufacturer or any other party. The opinions and findings of the Association represent its professional judgement given with due consideration to the necessary limitations of practical operation and state of the art at the time the Standard is processed.

Products in substantial accord with this Standard but which exhibit a minor difference or a new feature may be deemed to meet the Standard providing the feature or difference is found acceptable utilizing appropriate CSA Certification Division Operating Procedures. Products which comply with this Standard shall not be certified if they are found to have additional features which are inconsistent with the intent of this Standard. Products shall not be certifiable if they are discovered to contravene applicable Federal laws or regulations.

Testing techniques, test procedures and instrumentation frequently must be prescribed by the CSA Certification Division in addition to the technical requirements contained in Standards of CSA. In addition to markings specified in the Standard the CSA Certification and Testing Division may require special cautions, markings and instructions that are not specified by the Standard.

Some tests required by CSA Standards may be inherently hazardous. The Association neither assumes nor accepts any responsibility for any injury or damage that may occur during or as the result of tests, wherever performed, whether performed in whole or in part by the manufacturer or the Association, and whether or not any equipment, facility or personnel for or in connection with the test is furnished by the manufacturer or the Association.

Manufacturers should note that, in the event of the failure of the CSA Certification and Testing Division to resolve an issue arising from the interpretation of requirements, there is an appeal procedure: the complainant should submit the matter, in writing, to the Secretary of the Canadian Standards Association.

If this Standard is to be used in obtaining CSA Certification please remember, when making application for certification, to request all current Amendments, Bulletins, Notices and Technical Information Letters that may be applicable and for which there may be a nominal charge. For such information or for further information concerning details about CSA Certification please address your inquiry to the Applications and Records Section,

Canadian Standards Association, 178 Rexdale Boulevard, Rexdale
(Toronto), Ontario M9W 1R3.

Publication Date--November 30, 1988

(ie, the date on or after which this Standard may, at the
discretion of the applicant, be used for certification).

Effective Date--November 30, 1989*

(ie, the date on which this Standard shall be applicable to
equipment being submitted for certification and to equipment
already certified and manufactured on or after that date).

*Unless otherwise noted in the text or General Instruction.

<http://www.china-gauges.com/>

<http://www.china-gauges.com/>

1. Scope

1.1

This Standard applies to air-heaters intended for use on nominal system voltages of 600 V or less, designed to be used in accordance with the Rules of the *Canadian Electrical Code*, Part I.

1.2

This Standard applies to permanently connected and cord connected air-heaters for household, commercial and industrial use in non-hazardous locations.

1.3

The term air-heater includes the following types:

- (a) convection;
- (b) forced air;
- (c) radiation;
- (d) ceiling types only, or in combination with either lighting or ventilating components, or both;
- (e) liquid-filled radiator; and
- (f) combinations of (a), (b), or (c).

Note: For convenience, except where distinction is necessary, portable and stationary air-heaters are referred to throughout this Standard as "heaters".

1.4

This Standard does not apply to

- (a) unit heaters involving only steam or hot water heating with an electric air-circulator;
- (b) electric duct heaters, as covered in CSA Standard C22.2 No. 155;
- (c) central electric warm air furnaces, as covered in CSA Standard C22.2 No. 23;
- (d) radiant ceiling heating panels, panel sets and systems, as covered in CSA Standard C22.2 No. 217.

1.5

Requirements for cord-connected double-insulated electric air-heaters are specified in Clause 7 of this Standard.

2. Definitions

2.1

The following definitions apply in this Standard:

Baseboard heater system--multiple sections consisting of some or all of the following components: heaters, receptacle units, control units, corner sections, and blank sections with provision for bonding and interconnection of heaters and component accessories.

Cord-connected heater--a heater that is connected to the electrical supply by a cord set or a power supply cord terminating in a suitable attachment plug.

Floor insert heater--a permanently connected heater intended to be installed in the floor.

Guard--that part of the enclosure provided for a heater element of the radiation type through which radiant energy is intended to pass. It also means that part of the enclosure of a forced air or convection heater through which the heated air is directed.

Heater element--a complete or partial assembly of heating element, electrical insulation (eg, refractory), metal sheath, glass or quartz envelope or panel, thermal insulation, and frame or adapter for holding the assembly together and fastening it in the heater; and leads or terminal connections, or both, which may or may not include bolts and nuts.

Heating element--the actual electrical conducting medium, which is intended to be heated by an electric current.

Industrial establishment--a building or part of a building (other than office or exhibit space) where persons are employed in manufacturing processes or in the handling of material, as distinguished from dwelling units, offices, and like occupancies.

Kickspace heater--a permanently connected heater equipped with a fan and designed primarily for being mounted at floor level flush with the kickspace under a counter.

Permanently connected heater--a stationary heater with provision for permanent connection to the electrical supply.

Portable heater--a cord-connected heater constructed for use in more than one location.

Notes:

(1) *A cord-connected heater having keyhole slots or equivalent integral mounting means will be tested in accordance with Clause 6.1.1.4.*

(2) *Magnets used for mounting cord-connected under-desk panel heaters are considered to be equivalent to keyhole slots, when used to hold the heater to the steel sides of the desk.*

Portable baseboard heater--a portable cord connected heater of a design that

(a) may be used as a baseboard heater; and

(b) has dimensions as follows:

(i) the height of the heater from the supporting surface to the top of the enclosure, excluding the supporting handle, is less than 455 mm;

(ii) the overall length of the heater is more than double the height; and

(iii) the depth of the heater (front to back), excluding projecting feet, is less than 125 mm.

Portable heaters meeting all but Item (b)(iii) of the above requirements for a portable baseboard heater shall be considered to be a portable baseboard heater unless marked in accordance with

Clause 5.19.

Positive temperature coefficient (PTC) heater element--an assembly consisting of one or more positive temperature coefficient heating elements, a means of electrical termination, and, in some cases, electrical insulation.

Positive temperature coefficient (PTC) heating element--a thermally sensitive semiconductor resistor that is intended to be heated by an electric current and shows a sharp resistance increase over a small temperature range.

Pressure relief device--a pressure actuated valve or rupture member designed to relieve excessive pressure automatically.

Radiant panel heater or liquid-filled radiator-type heater--a heater that both radiates and convects heat, primarily through its exposed heated enclosure surfaces.

Rupture member--a device that will rupture at a predetermined pressure.

Stationary heater--a heater intended to be fastened or secured at a specific location, or a heater that cannot be easily moved from place to place.

Note: Cord-connected heaters that are considered to be stationary heaters include some types of fireplace heaters, imitation fireplaces, chain-hung radiant ceiling heaters, bracket-mounted unit heaters, or heaters provided with means for mounting.

Stationary baseboard heater--a heater of a design having the following dimensions:

- (a) the air-intake and outlet areas of the convection or fan types, and the effective radiating area of the radiant types, are capable of being located within 455 mm of the floor; and
- (b) the ratio of the heater length to its height is not less than 2; the height being established as the distance from the bottom of the heater enclosure to the upper edge of the effective heating section of the heater, and the length as the length of the effective heating section of convection and fan type heaters and the effective radiating length of the radiant type.

Note: The following sketches of different heaters are shown to demonstrate the determination of the height (h) and the length (l) of the effective heating sections.

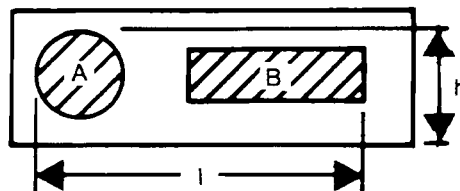

Fan Type

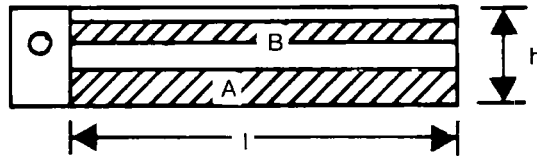

Convection Type

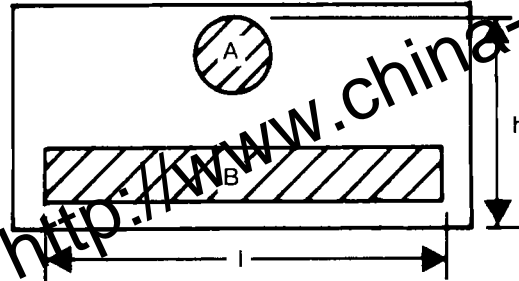

Fan Type Cabinet Style

Legend:

A = air intake

B = air outlet

Temperature-regulating control--a device that functions only to regulate the temperature under normal conditions of use, the failure of which would not result in a hazard.

Temperature-limiting control--a device that functions only under conditions that produce abnormal temperatures, the failure of which might result in a hazard.

Combination temperature-regulating and -limiting control--a device that functions to regulate the temperature under normal conditions of use and also serves to prevent a hazard that may result from conditions of abnormal operation of the heater.

3. General Requirements

3.1 General

General requirements applicable to this Standard are given in CSA Standard C22.2 No. 0, *General Requirements--Canadian Electrical Code, Part II*.

3.2 Reference Publications

3.2.1

Where reference is made to CSA Standards of the Canadian Electrical Code, Parts I and II, such reference shall be considered to refer to the latest edition and revision thereto. This Standard refers to the following such Standards, and the year dates shown indicate the latest editions available at the time of printing:

C22.1-1986,
Canadian Electrical Code, Part I;

C22.2 No. 0-M1982,
General Requirements--Canadian Electrical Code, Part II;

C22.2 No. 0.4-M1982,
Bonding and Grounding of Electrical Equipment (Protective Grounding);

C22.2 No. 0.6-M1982,
Flammability Testing of Polymeric Materials;

C22.2 No. 8-M1986,
Electromagnetic Interference (EMI) Filters;

C22.2 No. 14-M1985,
Industrial Control Equipment;

C22.2 No. 23-1980,
Electric Central Warm Air Furnaces;

C22.2 No. 24-1981,
Temperature-Indicating and Regulating Equipment;

C22.2 No. 42-M1984,
General Use Receptacles, Attachment Plugs and Similar Wiring Devices;

C22.2 No. 55-M1986,
Special Use Switches;

C22.2 No. 77-1976,
Motors with Inherent Overheating Protection;

C22.2 No. 100-M1985,
Motors and Generators;

C22.2 No. 111-M1986,
General Use Switches;

C22.2 No. 155-M1986,
Electric Duct Heaters;

C22.2 No. 217-M1985,
Radiant Ceiling Heating Panels, Panel Sets, and Systems.

3.2.2

Where reference is made to the following publications, such reference shall be considered to refer to that edition listed below:

CSA Standards

B35.2-1963 (Reaffirmed 1969),
Binding Head Screws;

CAN3-C235-83,
Preferred Voltage Levels for AC Systems, 0 to 50 000 V.

ASTM Standard

D635-81,
Rate of Burning and/or Extent and Time of Burning of Self-Supporting Plastics in a Horizontal Position.

ULC* Standard

S102.2-1975,
Standard Method of Test for Surface Burning Characteristics of Flooring and Floor Covering Materials.

*Underwriters' Laboratories of Canada.

4. Construction

4.1 General

4.1.1

Electric components of heaters shall be of types specifically approved for the use intended or shall be investigated as an integral part of, and with, the heater.

4.1.2

Electric components of heaters shall conform to the particular *Canadian Electrical Code, Part II*, Standard covering such components and shall be suitable for the application.

4.1.3

The input to cord-connected heaters for use on nominal 120 V branch circuits protected by overcurrent devices rated or set at not more than 15 A shall not exceed 1500 W at 115 V. (See Clause 6.2.)

4.2 Enclosures for Live Parts

4.2.1

Heaters shall have enclosures of noncombustible, moisture-absorption-resistant material, which shall enclose all live parts except power supply cords and except as permitted by Clauses 4.2.6 and 4.2.8.

4.2.2

Enclosures shall be so formed and assembled that they will

- (a) have the strength and rigidity necessary to resist the abuses to which they may be subjected and, at the same time, not increase the fire or accident hazard created by deformation of the enclosure and the resulting reduction of spacings, loosening, or displacement of parts, etc; and
- (b) afford protection against accidental contact with live parts.

4.2.3

Except as permitted by Clause 4.2.7.1, enclosures shall be judged with respect to size, shape, thickness of material, and

suitability for the particular application. Enclosure material shall be reinforced, or of such thickness and shape as to give stiffness and protection equivalent to that provided by blank, flat, sheet steel not less than 0.8 mm (No. 22 MSG) thick. Enclosures shall withstand the physical abuse tests specified in Clause 6.11.

4.2.4

The thickness for cast metal enclosures shall comply with Table 1.

4.2.5 Nonmetallic Enclosures and Supports

4.2.5.1

All enclosures and supports for electrical components shall

- (a) have mechanical, aging, and moisture-absorption-resistant properties suitable for the application;
- (b) have limiting temperatures not less than the maximum temperatures to which they may be exposed during normal operation; and
- (c) meet the flame test requirements specified in Clause 6.12.

4.2.5.2

Material in contact with incandescent lamps shall meet the requirements of Clause 4.2.5.1.

4.2.5.3

Plastic decorative parts (eg, imitation fire logs), fan blades, and handles not forming part of the enclosure shall meet the requirements of Clause 4.2.5.1(a) and (b); and shall not have a burning rate greater than 51 mm/min as determined by ASTM Standard D635 using samples not thicker than required for the tests specified in Clause 6.12.2.

Plastic air intake or exhaust guards or grills, whether decorative or functional, shall meet the flame test requirements of Clause 6.12.

4.2.6 Openings in Enclosures (Excluding Guards)

4.2.6.1

Ventilation openings and other openings in external enclosures shall be constructed, located, protected, or baffled so that a probe as shown in Figure 1 cannot be inserted that could touch terminals, switches, heating elements, wiring, and other live parts. For industrial heaters the 6.4 mm dimension in Figure 1 shall be 13 mm.

4.2.6.2

Openings in external enclosures shall not be located directly below terminals, switches, heating elements, metal-sheathed heater elements operating at more than 280°C, wiring and other live parts unless baffled in order to prevent molten metal and flaming particles, etc, from falling through to the supporting surface. (See also Clauses 4.2.6.7, 4.11.3, and 4.11.4.)

4.2.6.3

Insulated wiring protected by a suitable sleeving, power supply cords whose individual conductors are not separated, and power supply cords fixed in place shall be exempt from the requirements

of Clauses 4.2.6.1 and 4.2.6.2.

The sleeving shall be suitable for the temperature encountered, nonfraying, and retained in position.

4.2.6.4

Floor-insert heaters shall be provided with suitable drainage openings to prevent the accumulation of water or other liquids. These openings shall meet the requirements of Clause 4.2.6.1, except that only the 6.4 mm diameter probe shall be used.

4.2.6.5

If covers on fireplace heaters can be removed for the replacement of lamps, all live parts such as wiring and switches, with the exception of screwshells and centre contacts of lampholders, shall be enclosed to prevent contact by persons replacing the lamps.

4.2.6.6

Openings in wall-insert heaters shall be located or baffled to prevent the ejection of burning insulation, molten metal, and the like from the enclosure into the wall to become a fire hazard.

4.2.6.7

Notwithstanding Clause 4.2.6.2, ceiling or pendant-type heaters, marked in accordance with Clause 5.1.18 and provided with sheathed heater elements that are exposed to the supporting surface, may have temperatures in excess of 280°C on the surface of the element sheaths, provided

- (a) the sheaths are made of alloy steel or glass; and
- (b) the surface temperature of the sheaths does not exceed the continuous normal temperature rating of the sheath material.

4.2.6.8 Openings in Stationary Baseboard Heater Connection Boxes

4.2.6.8.1

Notwithstanding Clause 4.2.6.2, the total area of all open holes (such as mounting-screw holes, prying-out holes or slots, etc) in any one of the side, front, bottom, or top of the connection box of a baseboard heater shall not exceed 1.3 cm², except as permitted by Clauses 4.2.6.8.3 and 4.2.6.8.4.

4.2.6.8.2

The total area of such openings in each of the back and partition areas of the connection box shall not exceed 2.58 cm².

4.2.6.8.3

Clearance fits with 0.80 mm clearance or less shall not be included in the calculation of the total area of openings in accordance with Clause 4.2.6.8.1 or 4.2.6.8.2.

4.2.6.8.4

Except as required by Clause 4.2.6.2 and notwithstanding Clauses 4.2.6.8.1 and 4.2.6.8.2, an exception shall be permitted for ventilation openings, which may exceed the allowed opening area where

- (a) openings are baffled so that a 1.2 mm diameter straight rod cannot enter the connection box beyond the baffle from any angle; or
- (b) unbaffled openings that permit the insertion of the 1.2 mm

diameter rod of Item (a) but not the 6.4 mm diameter rod of Clause 4.2.6.1 are screened in accordance with Clause 4.2.6.8.5.

4.2.6.8.5

Screening permitted by Clause 4.2.6.8.4 shall comply with one of the following constructions:

- (a) a galvanized steel screen or the equivalent with a 14 x 14 mesh and wire having a diameter of 0.45 mm;
- (b) a panel in accordance with Table 2; or
- (c) a perforated metal panel or wire screen that complies with the dropping melted particles test in Clause 6.17.

4.2.7 Reflectors

4.2.7.1

Reflectors forming part of external enclosures of portable heaters (eg, reflector bowls, fireless heaters) shall be not less than 0.53 mm (No. 24 MSG) thick if made of sheet steel, not less than 0.85 mm (No. 18 AWG) thick if made of copper, and not less than 0.92 mm (No. 18 AWG) thick if made of aluminum.

4.2.7.2

The thickness of heater reflectors other than those specified in Clause 4.2.7.1 shall be adequate for the application.

4.2.7.3

The aging characteristics of reflector surfaces, especially plated surfaces, shall be such that deterioration of the surface or flaking will not result eventually in failure of the heaters to pass the temperature tests.

4.2.7.4

Heaters having reflectors with adjustable bases shall be so constructed that adjustment of the bases will not result in mechanical injury to electrical parts.

4.2.8 Guards for Heater Elements

4.2.8.1

Heater elements shall be so guarded that persons and combustible material will be protected from accidental contact with

- (a) heating elements;
- (b) bare live parts; and
- (c) parts of the heater element (eg, sheath, fins, glass panel, heating element supports).

4.2.8.2

Guards for portable heaters shall provide protection when the heaters are in any normal operating position. Guards shall not be detachable from portable heaters for shipping purposes.

4.2.8.3

Guards shall be of rigid construction and, as a unit, shall be so held in position on the heater by screws or by some equivalent means as to be not readily detachable.

4.2.8.4

Guards shall be sufficiently strong to retain their shape even under conditions of excessive physical strain that may occur in ordinary operation and handling. The size and shape of the guard and the degree of compression of the guard necessary to cause failure of the heater under the abnormal temperature test conditions for Clause 6.6.5 shall be considered.

4.2.8.5

Heaters intended for suspension from ceilings or for mounting on walls, where the bottom of the heater is more than 1.4 m above the floor or grade and marked in accordance with Clause 5.1.18, shall comply with the following:

- (a) No guarding of the heater element is required if the heater has no exposed live parts; and
- (b) If the heater has exposed live parts, guards meeting the requirements of Clause 4.2.8.4 shall be provided.

4.2.8.6

Openings in the area covered by a guard shall not be located directly below open-coil type heating elements or other bare live parts of the heater element unless such parts are baffled. This requirement shall apply with the movable reflector, or the heater if stationary, in any normal position. This requirement shall not apply to heating elements enclosed in metal, quartz, or a similar sheath regardless of the sheath temperature.

4.2.8.7

Air-heaters, other than those covered by Clauses 4.2.8.9, 4.2.8.10, 4.2.8.11, 4.2.8.12, and 4.2.8.13, shall comply with guarding requirements as follows:

- (a) Clause 4.2.8.8(a), (b), and (c), for heaters with exposed heating elements or heater elements whose surface temperature, under normal operating conditions, exceeds 280°C; and
- (b) Clause 4.2.8.8(a), for heaters with heater elements whose surface temperature, under normal operating conditions, exceeds 90°C but does not exceed 280°C.

4.2.8.8

Openings in guards shall be acceptable if the following conditions are met:

- (a) The shape and size of an opening are such that a test probe in the form of a right circular cone with a base diameter of 70 mm and an altitude of 140 mm is prevented from touching the parts described in Clause 4.2.8.1 when the probe is inserted, apex first, in any manner.
- (b) The shape and size of an opening that permits the vertical downward entrance of a bar 12.7 mm wide and 1.6 mm thick are such that a test probe 1.6 mm thick and in the form of an isosceles triangle with a base of 70 mm and an altitude of 140 mm is prevented from touching the parts described in Clause 4.2.8.1 when the gauge is inserted, apex first, in any manner.

The testing of an opening with the triangular probe described in the preceding paragraph applies also where the vertical downward insertion of the bar is prevented either by the construction of the guard, or by the use of an additional barrier, unless the vertically applied bar tends to be deflected outward (ie, away from the guard).

(c) The area of an opening in a substantially vertical face of a guard is not more than 21 cm² where the size and shape of the opening permit the entrance, from any horizontal direction, of a vertical rod 1.6 mm in diameter and 70 mm long.

4.2.8.9

For heaters other than those covered by Clause 4.2.8.13, fan type heaters shall meet the requirements of Clause 4.2.8.7, except that if the fan is always in operation when the heater element is in the ON position (energized) and the air flow prevents anything and the like from entering the guard, openings in the guard will be acceptable if they comply with Clause 4.2.8.8.

4.2.8.10

Except as otherwise indicated, guards for radiant panel heaters or liquid-filled radiator-type heaters shall be provided as follows:

(a) If the maximum surface temperature of the radiant panel heater or liquid-filled radiator-type heater is between 90°C and 280°C, a guard is required. The openings in the guard shall not exceed 129 cm² in area and shall prevent a test sphere 102 mm in diameter from touching that surface of the radiant panel heater or liquid-filled radiator-type heater.

(b) If the radiant panel heater or liquid-filled radiator-type heater surface temperature is 90°C or lower, a guard need be provided only if necessary to enable a heater to pass the mechanical test outlined in Clause 6.11.

(c) If the surface temperature of the radiant panel heater or liquid-filled radiator-type heater exceeds 280°C, the guard shall meet the requirements of Clause 4.2.8.8(a), (b), and (c).

(d) Radiant panel heaters or liquid-filled radiator-type heaters designed for installation in ceilings need not be provided with guards.

4.2.8.11

Guards for metal grates and fireplace heaters shall be the subject of investigation. In general, guarding will be considered adequate if

(a) the curved reflector extends out at least to a point above the heater element; and

(b) the sides are enclosed with blank metal up to a level at least above that of the heater element.

4.2.8.12

Guards for floor-insert heaters shall

(a) meet the requirements of Clause 4.2.8.8(b);

(b) prevent a straight 6.4 mm diameter rod from touching the parts described in Clause 4.2.8.1(a) and (b); and

(c) prevent debris from falling on the parts described in Clause 4.2.8.1(a) and (b).

4.2.8.13

Guards for portable and stationary baseboard heaters shall comply with the following guarding requirements:

(a) If the temperature of any part of the heater element does not exceed 280°C under conditions of normal operation, openings in the guard shall be acceptable if they comply with Clause 4.2.8.8(a).

The fins of a metal-sheathed element are considered to be element-guarding members and need not comply with the provisions

of this Clause if the temperature of the exposed edges (outer perimeter) of the fins does not exceed 280°C.

(b) If the temperature of any part of the heater element exceeds 280°C under conditions of normal operation, the size and shape of an air exit opening shall be such that a test probe 1.6 mm thick and in the form of an isosceles triangle having a base of 70 mm and an altitude of 140 mm is prevented from touching bare live parts or heater elements (including fins) whose temperature exceeds 280°C when the probe is inserted, apex first, in any manner.

4.2.8.14

In addition to the guarding requirements of Clause 4.2.8.12, stationary and portable baseboard heaters, unless they comply with the shredded paper test requirement of Clause 6.6.6.7, shall be provided with wire guards or the equivalent in any slot openings of the heater outer enclosure and such guards shall be spaced so that no section of slot opening is uninterrupted for a distance of more than 152 mm.

4.2.9 Guards for Moving Parts

4.2.9.1

The distance from an opening in a required guard or enclosure to a moving part such as a fan blade, blower wheel, pulley, belt, etc shall be in accordance with Table 3, but the minor dimension of the opening shall not in any case exceed 25.4 mm. For an opening having a minor dimension intermediate between two values shown in Table 3, the distance from the opening to the moving part shall be not less than that found by appropriate interpolation between the corresponding values in the righthand column of the table. The minor dimension of the opening shall be determined by the largest hemispherically tipped cylindrical probe that can be inserted through the opening with a force of 22.2 N.

4.2.9.2

Heaters intended for suspension from ceilings or for mounting on walls, so that the bottom of the heater is more than 2.4 m above floor or grade and marked in accordance with Clause 5.18, need not be guarded.

4.3 Protection Against Corrosion

4.3.1

Ferrous metal parts shall be protected against corrosion as required by CSA Standard C22.2 No. 0.

4.3.2

The surfaces of metal parts shall be protected, where necessary, against scaling, flaking, or other corrosive effects, which during normal use might reduce dielectric strength or result in spacings below the acceptable minimum values specified in Clause 4.18.

4.4 Mechanical Assembly

4.4.1

Parts used in the construction of heaters shall have adequate strength and shall be assembled and secured in position to ensure

acceptable functioning under both normal and abnormal conditions which may be met in service.

4.4.2

Switches, lampholders, thermostats, etc shall be fastened securely and rigidly to maintain the spacings required by Clause 4.18.

4.4.3

The operating mechanism of switches or controls shall not subject electrical parts to undue strain.

4.4.4

Screws or other fastenings of fragile insulating parts shall not be so tight as to result in cracking or breaking of such parts due to expansion and contraction, unless the insulating material is completely retained. Generally, such parts shall be slightly loose or shall be provided with cushioning material.

4.4.5

Cord-connected heaters provided with supporting feet or stands that can be detached, retracted, or folded shall be

(a) marked with the applicable cautions of either Clause 5.1.22 or Clause 5.1.23; and

(b) subjected to all the applicable tests, except the stability test of Clause 6.18, with the feet/stand both attached or extended and detached or folded, as the case may be.

4.4.6

Heaters that are rendered inoperable when the feet or stand are removed are exempted from the requirements of Clause 4.4.5.

4.5 Receptacles

4.5.1

Receptacles shall comply with CSA Standard C22.2 No. 42 and shall be provided only on stationary heaters.

4.5.2

Receptacles shall be of the grounding type and have a configuration in accordance with Diagram 1 of CSA Standard C22.1.

4.5.3

Receptacles on stationary baseboard heaters, or in accessory units which are used with stationary baseboard heaters to assemble a baseboard heating system, shall not be connected to the branch circuit supplying the heater (see Clause 4.6.1.7).

4.6 Supply Connections

4.6.1 Permanently Connected Heaters

4.6.1.1

Permanently connected heaters shall have provision for the connection of armoured cable, nonmetallic sheathed cable or conduit, except for ceiling-mounted heaters meeting the conditions specified in Clause 4.6.1.5.

4.6.1.2

Supply connections shall be made within either terminal or outlet boxes, or they may be made within the enclosure of heaters, provided that

- (a) the area is free of moving parts such as fans;
- (b) the supply connections are confined to a designated area through such means as a terminal block or a barrier;
- (c) the degree of enclosure is not less than that required by Clause 4.2.6; and
- (d) the heater wall where conduit connection is made is not less than 0.80 mm (No. 20 MSG) thick if of sheet steel, or has equivalent rigidity if of other metal.

4.6.1.3

The location of terminal boxes or compartments in which supply connections are made shall be such that the connections will be readily accessible for inspection after heaters are installed as intended, but to gain access it will first be necessary to open a cover that is adequately secured by at least two screws or the equivalent. Electric parts shall not be attached to such covers.

4.6.1.4

If the heater face, guard, heater element, controls, etc, are removable as one unit, the complete section may serve as the inspection cover, provided undue stress is not transmitted to supply conductors.

4.6.1.5

Provision for permanent connection to the power supply shall not be required for ceiling-mounted heaters that are intended to be attached to and supported by a standard outlet box in the ceiling, provided that the following conditions are met:

- (a) the heater has a mass of 22.7 kg or less;
- (b) if leads are provided for connection to the supply conductors, they shall be not less than 152 mm in length;
- (c) the temperature on the supply wiring in the outlet box does not exceed 60°C when the heater is tested according to Clause 6.4.7; and
- (d) the heater bears the marking of Clause 5.1.8.

4.6.1.6

Ceiling heaters intended to be mounted on an outlet box in the ceiling, if they have a mass of more than 4.5 kg, shall have a construction that will permit inspection of the supply connections without the necessity of removing the heater.

4.6.1.7

If a stationary baseboard heater has provision for connecting two separate supplies, such as separate circuits for heater and receptacles, the bare live parts of the two circuits shall be separated from each other by a suitable barrier.

4.6.1.8

Leads for connection to the supply that are provided with the heaters shall be not less than 152 mm in length and made of at least No. 16 AWG copper, except for leads external to the heaters, which shall be made of at least No. 14 AWG copper.

4.6.2 Portable Heaters

4.6.2.1

Portable heaters shall have a power supply cord which shall extend not less than 1.8 m and not more than 2.4 m from the point where the cord enters the heater to the face of the attachment plug.

4.6.2.2

Attachment plugs shall comply with the requirements of CSA Standard C22.2 No. 42.

4.6.2.3

For heaters having a maximum external surface temperature that exceeds 90°C on any surface, as determined by the normal temperature test of Clause 6.4, thermoplastic insulated flexible cords shall be provided as follows:

- (a) for household heaters, Type HPN, HPD, or the equivalent; and
- (b) for industrial and commercial heaters, Type SJOW (90°C) or the equivalent.

4.6.2.4

For heaters having a maximum external surface temperature that does not exceed 90°C on any surface likely to be contacted by the cord, as determined by the normal temperature test of Clause 6.4, thermoplastic insulated flexible cords may be provided as follows:

- (a) for household heaters, Types SPT-2 (105°C), SVT (105°C), or the equivalent; and
- (b) for commercial heaters, Type SJT (105°C) or the equivalent.

Note: On a portable heater it is considered that any external surface that can be contacted by the cord is likely to be contacted by the cord.

4.6.2.5

Except for the maximum input requirement for 120 V cord-connected heaters as outlined in Clause 4.1.3, the ampere rating of the heaters shall be limited to not more than 80% of the attachment plug rating.

4.6.3 Terminal Parts

4.6.3.1

Wire-binding terminal parts, and the identification of terminal parts and leads shall comply with the applicable requirements of CSA Standards C22.2 No. 0, C22.2 No. 65, C22.2 No. 158, and B35.2.

4.6.3.2

Wiring terminals shall be prevented from turning. Friction between surfaces is not an acceptable means of preventing the turning of terminal parts.

4.6.3.3

Cord-connected stationary heaters and portable heaters having polarized attachment plugs requiring connection to a neutral conductor shall have one terminal or lead identified for the connection of the identified conductor of the supply circuit or supply cord if they have lampholders, receptacles, heater element holders of the screwshell type, single-pole switches, or automatic controls having a manually operable single-pole switch.

4.6.3.4

Quick connect terminals shall meet the requirements of CSA Standard C22.2 No. 153.

4.6.4 Strain Relief

4.6.4.1

Strain relief shall be provided where a power supply cord enters an enclosure so that mechanical strain on the cord will not be transmitted to terminals, splices, or internal wiring. (See Clause 6.8.)

4.6.4.2

Means shall be provided to prevent flexible cords from being pushed into the heater through the cord entry holes, if such displacement is liable to subject the cords to mechanical injury, to expose them to temperatures above their approved limit or to reduce spacings (such as from bare live parts to a metal strain relief) below the acceptable minimum values.

In the case of flat cords (eg, HPN) having parallel conductors which may be separated, the strain relief may be applied to the separated conductors, provided the separated portion of the cord does not extend outside the heater enclosure or bushing.

4.6.4.3

At the point where a flexible cord passes through an opening in a wall, barrier, or enclosure, there shall be a suitable bushing or some equivalent which shall be substantial and reliably secured in place, and shall have a smoothly rounded surface against which the cord may bear.

If the hole for the cord is in porcelain, phenolic composition, or other suitable insulating material, or if the metal wall is folded, a smooth, rounded surface may be considered equivalent to a bushing.

4.6.4.4

If the power supply cords are inferior in serviceability to Type HSJO, and if the walls and barrier, etc are of metal, bushings of noncombustible, moisture-absorption-resistant insulating material shall be provided.

Insulated metal grommets may be accepted in lieu of insulating bushings, provided that the insulating material used is not less than 0.80 mm thick and that it fills completely the space between the grommet and the metal in which it is mounted.

4.6.4.5

If a knot in a power supply cord serves as strain relief, the surface against which the knot may bear or with which it may come into contact shall be free from projections, sharp edges, etc.

4.6.4.6

Metal clamps, unless they are used with suitable supplementary insulation, shall not be used as strain relief means on cords inferior in serviceability to Type HSJO flexible cord.

4.7 Electrical Insulation

4.7.1

Bare live parts shall be supported on heat-resistant, moisture-absorption-resistant insulating material which is suitable for its particular application and which will withstand the most severe conditions likely to be encountered in service.

4.7.2

The acceptability of insulating material shall include consideration of the following:

- (a) mechanical strength;
- (b) dielectric strength;
- (c) insulation resistance;
- (d) heat- and moisture-absorption-resistant properties;
- (e) degree of enclosure or protection; and
- (f) other factors which may have a bearing on the fire and accident hazard under conditions of actual use.

Note: Materials such as mica, porcelain, phenolic composition, cold-moulded, and certain refractory materials are generally acceptable as the sole support of live parts. Other materials which are not suitable for general use may be acceptable if used in conjunction with other more suitable materials, or if located and protected so that exposure to mechanical injury and the absorption of moisture are prevented.

4.7.3

Bare live parts such as terminal pins, studs, bolts, etc, if they pass through metal, shall be insulated from such metal by

- (a) washers of mica or other suitable insulation fitting closely in well defined indentures not less than 0.80 mm in depth, formed in the metal;
- (b) bushings of lava, porcelain, or other ceramic insulation having a wall thickness of not less than the dimensions given in Item C of Table 4, and surrounding the live part for approximately the full thickness of the metal; or
- (c) some other suitable insulating material and alternate means of mounting that will prevent shifting of the live part and provide the required spacings of Items B(1) and C of Table 4.

4.8 Thermal Insulation

4.8.1

Thermal insulation shall be suitable for the particular application and shall be adequately enclosed and retained to prevent loss and shifting.

4.8.2

Thermal insulation such as mineral wool, which may contain conductive impurities, shall not be in contact with bare live parts.

4.8.3

Thermal insulation shall not have a flame spread rating over 25 or a smoke-developed rating over 50 when tested in accordance with ULC Standard S102.2.

4.9 Current-Carrying Parts

4.9.1

Current-carrying parts shall have adequate mechanical strength and ampacity for the service and shall be of metal suitable for the particular application.

Note: Stainless steel, suitably plated iron or steel, cast iron and other corrosion resistant metal may be used for current-carrying parts without restriction as to temperature.

4.9.2

Bare current-carrying parts shall be rigidly supported so that the spacings required by Clause 4.18 will be maintained.

4.10 Wiring

4.10.1

Wiring connections and wires between parts of heaters shall be adequately protected or enclosed. (See also CSA Standard C22.2 No. 0.)

4.10.2

Raceways shall be smooth and entirely free from sharp edges, burrs, moving parts, etc, which may cause abrasion of the insulation on conductors.

4.10.3

Holes in sheet metal walls through which insulated conductors pass shall be provided with smoothly rounded bushings or shall have smooth, well rounded surfaces upon which the wires may bear.

4.10.4

The internal wiring of heaters shall consist of wire of a type or types considered suitable for the particular application in light of the following criteria:

- (a) temperature and voltage to which the wire is liable to be subjected; and
- (b) other conditions of service which are liable to have a deleterious effect on the insulation.

4.10.5

The ampacity of conductors shall be such that the limiting temperatures for the insulation are not exceeded.

4.10.6

Connectors, joints in conductors, and the insulation thereon shall comply with the requirements of CSA Standard C22.2 No. 0 unless they are held securely and rigidly so that the spacings required by Clause 4.18 will be maintained.

4.11 Heating and Heater Elements

4.11.1

Heating elements shall be supported in a substantial and reliable manner, and shall be protected against mechanical injury and contact with outside objects, as provided for in Clause 4.2.8.

4.11.2

Heating elements shall be so constructed and supported that short circuits cannot occur between turns, between sections of the heating elements, or between bare live and non-current-carrying metal parts when the heater is subjected to any of the applicable temperature abnormal tests specified in Clause 6.6.

Note: Coiled-wire heating elements may be supported on porcelain hook-type insulators depending upon the stiffness of the coil, the spacing between hooks, the shape of the hook, etc.

4.11.3

The heater element sheath of stationary baseboard heaters shall be located so that no part of the sheath is directly above the floor. The enclosure material shall extend from the back of the heater to the front edge of the heater element sheath.

4.11.4

Stationary baseboard heaters with aluminum heater element sheaths containing powdered or compacted powdered mineral insulators to insulate the sheath from the heating element shall be baffled in such a manner that there is no line of sight between the sheath material and the air inlet or outlet. Baffles and louvres in these baffles shall be so angled that molten metal, etc will be directed into the heater enclosure.

Note: Clause 4.11.4 is not intended to include aluminum-sheathed heater elements used in combination with internal ceramic insulators to support the heating element.

4.11.5

Aluminum-sheathed heater elements referred to in Clause 4.11.4 shall be protected in such a manner that, in the event of failure, the failing part of the element cannot sag below the front cover or baffles referred to in Clause 4.11.4.

4.11.6

Porcelain insulators of all types shall be retained in place by means other than the heating element.

4.11.7

Heating elements shall be securely fastened to terminals (eg, under the heads of terminal binding-screws).

4.11.8

Heaters intended for operation on circuits having a voltage of more than 150 volts-to-ground shall not have open-wire heating elements unless the degree of enclosure is that required by Clause 4.2.6.1.

4.11.9

If the head of a screw is used as the centre contact for replaceable heater elements using screwshells, it shall be free from burrs.

4.11.10

If a screw is used to fasten one end of the heating element wire to a base screwshell, it shall not prevent the heater element from bottoming in the holder.

4.11.11

The panel of radiant-panel type heaters shall be supported so that normal expansion and contraction and warping of the enclosure created by mounting will not cause undue strain on the panel.

4.12 Protection Against Overheating

4.12.1

Heaters of the radiator type in which a liquid is heated and which may operate when dry shall be provided with means to prevent unsafe temperature from being attained when the heater is operated dry at the voltage required by Clause 6.3.

4.12.2

Heaters in which the heating element operates in an air stream from a fan or other moving part shall be capable of safe operation without air flow, or shall have means to prevent unsafe temperatures in the event of failure of the air flow.

4.12.3

Fusible links provided in heaters to prevent the attainment of unsafe temperatures due to abnormal operation of heaters shall be so constructed or enclosed as to prevent tampering and shall operate without the short-circuiting or grounding of live parts (see also Clause 6.11).

4.12.4

Except as permitted by Clause 4.12.5, temperature-limiting controls, when used to control a magnetic contactor or other auxiliary or regulating control which de-energizes the heater element circuit, shall be in a circuit which is electrically and mechanically independent from the temperature-regulating control. The contactor or other auxiliary control which de-energizes the heater element circuit shall be one that has been tested for the same number of endurance cycles as the temperature-limiting control.

4.12.5

Where both the temperature-limiting and -regulating controls are in the same circuit and are used to actuate a magnetic contactor or auxiliary control the following shall be met:

- (a) for air heaters where the temperature-limiting control is required to pass 100 000 endurance cycles, the auxiliary control shall be one that has been tested for 250 000 endurance cycles for making and breaking of the load controlled;
- (b) for heaters where the limit control is required to pass 6000 endurance cycles or less, the auxiliary controls shall be ones that have been tested for 100 000 endurance cycles.

4.12.6

Kickspace heaters and floor insert heaters shall be provided with a manual reset or one shot protector such that with all other controls shunted out of the circuit, the heater shall not become a fire hazard under abnormal test conditions.

4.12.7 Parts Under Pressure

4.12.7.1

The requirements of Clause 4.12.7.2 apply to parts of vessels that are under pressure of any gas, vapour or liquid and which fall within the following limits:

- (a) vessels having an inside diameter of 152 mm and under with no restriction on internal volume;
- (b) vessels having an internal diameter over 152 mm but which have an internal volume of 0.0425 m³ or less; and
- (c) vessels having an internal volume of 0.0425 m³ or less with no restriction on inside diameter.

4.12.7.2

Except as permitted by Clause 4.12.7.3, a part of a heater that is subject to internal pressure, during either normal or abnormal operation, shall withstand without failure a pressure equal to the highest of the following that is applicable:

- (a) five times the pressure corresponding to the maximum setting of a pressure-reducing valve provided as part of the assembly, but no more than five times the marked maximum supply pressure from an external source, and no more than five times the pressure setting of a pressure relief device provided as part of the assembly;
- (b) five times the marked maximum supply pressure from an external source, except as provided in Item (a);
- (c) five times the pressure setting of a pressure relief device provided as part of the assembly;
- (d) five times the working pressure marked on the part, if so marked;
- (e) five times the maximum pressure developed within the part during any of the applicable normal or abnormal operation tests covered by this Standard.

4.12.7.3

A test need not be performed to determine whether or not a part complies with the requirement in Clause 4.12.7.2, if study and analysis indicate that the strength of the part is adequate for the purpose as a result of its material and dimensions, eg, copper or steel pipe of standard size provided with standard fittings.

4.12.7.4

If a test is necessary to determine if a part complies with the requirements of Clause 4.12.7.2, two samples of the part shall be subjected to the applicable hydrostatic test specified in Clause 6.16.1.

4.12.7.5

Parts under pressure shall have protective means such as a fusible plug, rupture member, or pressure relief valve; or shall be so constructed that some part of the system will relieve the pressure. A means for automatically relieving pressure shall be provided for all parts in which pressure might be generated in the event of a fire.

4.12.7.6

Pressure relief devices may be employed to comply with the requirements in Clause 4.12.7.5.

4.12.7.7

There shall be no shut-off valve between the pressure relief means and the vessels and part(s) under pressure that it is intended to protect.

4.12.7.8

The start-to-discharge pressure setting of the pressure relief means shall not be higher than the withstand pressure as determined by Clause 4.12.7.2.

4.12.7.9

The means for pressure relief shall

- (a) be located as close as possible to the pressure vessel or parts of the system that it is intended to protect;
- (b) be so located that it is accessible for inspection and repair, and cannot be readily rendered inoperative;
- (c) have its discharge opening so located and directed that the possibility of scalding has been reduced to an acceptable degree; and
- (d) have the discharge opening so located and directed that operation will not deposit any discharged material on bare live parts, or on insulation or components that may be affected detrimentally.

4.12.7.10

A pressure relief device having an adjustable setting shall be judged on the basis of its maximum setting unless the adjusting means is sealed at a lower setting.

4.12.7.11

The acceptability of fusible plugs as pressure relief devices shall be determined by subjecting three representative samples of the fusible plug to the test of Clause 6.16.2. A fusible plug shall function within 5°C of its marked temperature rating.

4.12.7.12

Pressure relief means shall not discharge during the applicable normal temperature test of Clause 6.4 and applicable abnormal temperature test of Clause 6.6 that the heater is required to meet.

4.12.7.13

Liquids used as heat transfer mediums in air heaters shall have a flash point which is at least 10% higher than the maximum temperature to which the liquid in the heater is subjected either under normal or abnormal test conditions.

4.13 Lampholders and Lamps

4.13.1

Lampholders shall be prevented from turning by means other than friction.

4.13.2

Lampholders and lamps shall be protected from mechanical injury.

4.13.3

Lampholders of stationary heaters and portable heaters equipped with a polarized attachment plug shall have the screwshells connected to the identified conductor, if one is used, of the heater circuit.

4.13.4

Lampholders shall be located so that no bare live parts other than the screwshell will be exposed to contact by persons replacing lamps unless the lamps are not readily accessible, in which case a tool is required for removing a cover.

4.13.5

Lampholders intended for the support of heater elements shall be investigated as a component part of the heater, unless they are of the unswitched, medium-base, porcelain type with screwshells of copper or copper alloy and plated with nickel or an equivalent oxidation-resistant metal.

4.13.6

Medium-base lampholders shall not be used as holders for heater elements rated at more than 6 A or 660 W except that screwshells with lefthand threads may be used with heater elements rated at not more than 10 A.

4.14 Switches and Controls

4.14.1

Switches and controls shall comply, as applicable, with the requirements of CSA Standards C22.2 No. 14, C22.2 No. 24, C22.2 No. 55, and C22.2 No. 111.

4.14.2

Switches and controls shall be suitable for their particular application and shall have current and voltage ratings not less than those of the circuits which they control when the heater is operated as described in Clause 6.4.10.

4.14.3

Switches and controls shall be capable of passing the applicable overload and endurance tests as described in Clauses 6.9 and 6.14.

4.14.4

If cord-connected stationary heaters and portable heaters provided with polarized attachment plugs are controlled by manually operated line switches or controls* with an indicated OFF position, such switches and controls shall disconnect all ungrounded conductors of the circuit controlled when in the indicated OFF position.

**An attachment plug is acceptable as an alternative to the line switch or control, provided the heater is rated under 30 A.*

4.14.5

Portable heaters provided with a non-polarized parallel blade attachment plug shall be provided with double-pole switches or temperature-regulating controls so that both supply lines are disconnected when the switch or control* is in the indicated OFF position. Single-pole switches, including those of temperature-

regulating controls, may be used in addition to the line switch to control lamps, motors or for heat selection or control, except that at least one heating element, motor or a readily visible long-life indicating lamp (neon lamp or equivalent) shall be left for control by the line switch.

**An attachment plug is acceptable as an alternative to the line switch or control, provided the heater is rated under 30 A.*

4.14.6 OFF Position

4.14.6.1

If a switch or a control that can be turned manually to an OFF position is used to control the heat output of one or more segments of a heater element, its OFF position, at least, shall be indicated on or adjacent to the switch. Instead of the foregoing method, keys or legends may be used for showing the operating positions of switches; they shall indicate at least the OFF position and shall appear in a conspicuous, permanent location.

4.14.6.2

A low temperature setting on a thermostat shall not be considered as a true OFF position and shall not be so marked unless the thermostat does not reclose when cooled to a temperature of -35°C .

4.14.6.3

If an auxiliary temperature control or combination temperature control and control switch in a heater has a position marked OFF, or another marking (eg, NO HEAT, COLD, the symbol O, or equivalent) that conveys the same meaning as the word OFF, it shall disconnect all ungrounded conductors of the heater circuit when placed in that position (ie, when not cycling).

4.14.6.4

The OFF position only may be marked by the symbol O.

4.14.7

Switches used on heaters shall be so located or protected that in normal use they will not be subjected to mechanical injury.

4.15 Overcurrent Protection

Where fuses are used for overcurrent protection of heater element circuits they shall be HRC Form I, time delay type marked "D", or type "P", and the heater shall be marked as specified in Clause 5.1.17.

4.16 Motors

4.16.1

Motors shall be suitable for the particular application and shall comply insofar as applicable with the requirements of CSA Standards C22.2 No. 77 and C22.2 No. 100.

4.16.2

Openings in motor enclosures shall comply with Clause 4.2.6.1, except that motors completely within the heater enclosure may be of the open type.

4.17 Suppressors

Suppressors used for suppressing radio interference shall comply with the requirements of CSA Standard C22.2 No. 8.

4.18 Spacings

4.18.1

Spacings in components of heaters (eg, switches, lampholders, thermostats) shall comply with the requirements of that Standard of the *Canadian Electrical Code, Part II* which is applicable. Where there is no applicable Standard, spacings shall be the subject of investigation.

4.18.2

Except as specified in Clause 4.18.1, the spacings in heaters shall be not less than those shown in Table 4. If a bare live part is not rigidly supported or if a movable non-current-carrying metal part is in proximity to a bare live part, the construction shall be such that the minimum spacing specified will be maintained under all conditions of normal operation.

4.18.3

In place of the required spacings of Table 4, an insulating barrier or liner may be used to obtain the equivalent spacings, provided that it is

(a) of adequate dielectric strength and resistant to absorption of moisture;

(b) not adversely affected by arcing and suitable for the temperature encountered;

(c) of adequate mechanical strength and permanently retained in place; and

(d) not less than 0.66 mm thick, except that it may be not less than

(i) 0.33 mm thick if used in conjunction with a spacing not less than one-half of that required; or

(ii) 0.25 mm thick if of mica or other equivalent insulating material. The insulating barriers or liners shall be held in position between the parts involved by mechanical means (no spacing required). The use of adhesive to affix such insulation in place shall be subject to investigation.

4.19 Grounding and Bonding

4.19.1

A cord-connected household heater for operation on a nominal system voltage of 120 V is not required to be grounded.

4.19.2

In-car heaters, cord-connected commercial and industrial heaters, and all permanently connected heaters shall have provision for grounding except for heaters not having exposed conductive parts that may become energized, and double-insulated heaters.

4.19.3

Heaters required to be grounded shall be constructed to comply with the requirements of CSA Standard C22.2 No. 0.4.

4.19.4

Grounding conductors in heaters shall have insulation equivalent to that of live conductors if there is any likelihood of accidental contact with bare live parts.

4.19.5

In-car heaters shall be supplied with a suitable cord and attachment plug. The plug may be supplied detached from the cord but shall be packed with the heater, along with clear instructions indicating which conductor of the cord is to be connected to each of the terminals. The attachment plug end of the cord shall be properly stripped and the conductors twisted and binned to prevent loose strands.

4.20 Stability

Free-standing heaters shall meet the requirement for the stability test of Clause 6.18.

4.21 Stand-off Guards for Cord-Connected Radiant Heaters

Stand-off guards, other than the heater element guards required by Clause 4.2.8, used on a cord-connected radiant heater and which are provided to enable the heater to comply with applicable normal and abnormal temperature tests shall be

- (a) attached to the heater enclosure by permanent means so that they cannot be removed without the use of tools;
- (b) of such shape and size as to prevent a 100 mm diameter test sphere from being inserted through the guard openings from any direction and touch the heater element guard. The area of the stand-off guard openings shall not exceed 235 cm². The test sphere shall be applied with a force of 22 newtons including the mass of the sphere.

5. Marking

5.1 Marking on the Product

5.1.1

Heaters shall be plainly marked, in a permanent manner, in a place where details will be readily visible after installation, without the use of tools, with the following:

- (a) manufacturer's name, trademark, or other recognized symbol of identification;
- (b) catalogue, style, model, or other type designation;
- (c) voltage;
- (d) if not suitable for use on dc, the letters "ac" after the voltage, or the symbol "~" or the frequency in hertz, if necessary;
- (e) total input in amperes or watts; and
- (f) any additional marking required for proper installation, eg, for motor starting;
- (g) for heaters utilizing PTC heater elements, the steady-state maximum rating at $25 \pm 1^\circ\text{C}$ and $0 \pm 1^\circ\text{C}$ as determined in Clause 6.2.1.1;
- (h) heaters requiring a time-delay fuse for starting below 0°C shall be clearly marked to indicate the type and rating of the

fuse required (see Clause 6.6.9).

5.1.2

Stationary baseboard heaters shall have the marking required by Clause 5.1.1 located within 305 mm of the righthand end of the heater when it is installed as intended, and the marking details shall be not less than 2.4 mm high.

Unless the marking is readable from a location within the following limits:

- (a) an angle not less than 45° to the plane of the surface on which the marking appears; and
- (b) not less than 610 mm from the floor; and
- (c) at a distance not more than 915 mm from the marking, a second marking shall be used in the required location. This second marking need not be permanent and shall have at least the rated volts and input watts.

5.1.3

Marking shall comply with CSA Standard C22.2 No. 0.

5.1.4

The month and year of manufacture, at least, shall be marked on the heater in a location accessible without the use of tools. Date coding, serial numbers or equivalent means may be used.

5.1.5

Unless it is otherwise obvious, stationary heaters which depend upon proper location or position for acceptable operation shall be marked (eg, TOP or BOTTOM and HAUT ou BAS) to indicate how they shall be installed.

5.1.6

A marking

CAUTION: USE SUPPLY WIRES SUITABLE FOR ...°C or equivalent,
and

ATTENTION : EMPLOYER DES FILS D'ALIMENTATION ADÉQUATS POUR ...°C,
or equivalent

shall be located near the supply entrance or on the nameplate if the temperature in the terminal box or the compartment intended for the supply connections exceeds 60°C in the normal temperature test. The temperature to be marked in the caution shall be 75, 90, or 105 for temperatures of 61-75°C, 76-90°C, or 91-110°C, respectively.

5.1.7

As required by Clauses 6.4.7 and 6.4.9, a marking in English and French shall be provided specifying the minimum installed distance from the heater to the adjoining wall or ceiling surfaces.

5.1.8

Ceiling heaters intended to be supported by a standard outlet box in the ceiling shall be marked as follows, or equivalent:

THIS HEATER IS FOR MOUNTING ON A STANDARD OUTLET BOX

and

CE RADIATEUR EST PRÉVU POUR MONTAGE SUR UNE BOÎTE DE SORTIE
STANDARD.

5.1.9

Except as permitted by Clause 4.6.1.7, heaters that are provided with more than one source of supply shall be marked as follows or equivalent:

WARNING: DISCONNECT ALL SUPPLIES BEFORE WORKING ON ANY CIRCUIT and

AVERTISSEMENT : DÉBRANCHER TOUTES LES ALIMENTATIONS AVANT D'EXÉCUTER DES TRAVAUX SUR UN CIRCUIT QUELCONQUE.

5.1.10

Where required by Clause 6.6.6.1, stationary wall-mounted heaters shall be marked as follows, or the equivalent:
DO NOT INSTALL BOTTOM OF HEATER LESS THAN 610 mm ABOVE FLOOR and

NE PAS INSTALLER LA PARTIE INFÉRIEURE DU RADIATEUR À MOINS DE 610 mm AU-DESSUS DU PLANCHER.

5.1.11

Baseboard heating systems shall be marked as follows:

(a) receptacle sections or kits shall bear the complete marking of Clause 5.1.1(a) and (b);

(b) control sections or kits, both baseboard and wall types, shall bear the complete marking of Clause 5.1.

5.1.12

Heaters intended for use in industrial establishments only shall be marked as follows, or equivalent:

FOR INDUSTRIAL USE ONLY

and

POUR USAGE INDUSTRIEL SEULEMENT.

5.1.13

Baseboard heaters designed for the interconnection of baseboard heaters and heating systems components shall be marked at each connection box as follows:

THIS CONNECTION BOX (IS*) APPROVED FOR INTERCONNECTION OF BASEBOARD HEATERS AND COMPONENTS WHICH ARE ON THE SAME HEATING BRANCH CIRCUIT

and

CETTE BOÎTE DE CONNEXION (EST APPROUVÉE†) POUR L'INTERCONNEXION DE PLINTHES CHAUFFANTES ET DE COMPOSANTS RACCORDÉS AU MÊME CIRCUIT DE DÉRIVATION DE CHAUFFAGE.

**To be deleted when a wiring channel is provided, in which case the following shall be inserted: AND WIRING CHANNEL ARE.*

†To be deleted when a wiring channel is provided, in which case the following shall be inserted: ET LA CANALISATION DE CABLAGE SONT APPROUVÉES.

5.1.14

Stationary baseboard and wall-mounted heaters, which are provided with an air intake in the bottom of the enclosure and are intended to be installed a minimum distance above the finished floor level, shall be marked as follows, or equivalent:

INSTALL BOTTOM OF HEATER NOT LESS THAN ... mm ABOVE THE FINISHED FLOOR

and

INSTALLER LA PARTIE INFÉRIEURE DU RADIATEUR AU MOINS À ... mm AU-DESSUS DU PLANCHER FINI.

5.1.15

Through-the-wall and cabinet-type unit heaters shall be marked as follows, or equivalent:

CAUTION: FIRE HAZARD-DO NOT USE AIR DUCTS

and

ATTENTION : RISQUE D'INCENDIE-NE PAS UTILISER DE CONDUITS D'AIR

5.1.16

Heaters intended for operation with air ducts up to 760 mm maximum length both inlet and outlet shall be marked as follows, or equivalent:

CAUTION: WHEN AIR DUCTS ARE USED THE EXTERNAL STATIC PRESSURE SHALL NOT EXCEED ... OF WATER

and

ATTENTION : LORSQUE DES CONDUITS D'AIR SONT UTILISÉES, LA PRESSION STATIQUE EXTÉRIEURE NE DOIT PAS ÊTRE SUPÉRIEURE À ... mm D'EAU.

5.1.17

When required by Clause 4.15, the heater shall be marked as follows, or equivalent:

CAUTION: USE ONLY TIME DELAY FUSES MARKED "D", HRC FORM I FUSES, OR FUSES MARKED "P"

and

ATTENTION : EMPLOYER UNIQUEMENT DES FUSIBLES À ACTION DIFFÉRÉE, MARQUÉS "D" OU DES FUSIBLES HRC FORMAT I OU DES FUSIBLES MARQUÉS "P".

5.1.18

Heaters intended for suspension from ceilings or walls that are not adequately guarded to prevent accidental contact with moving parts shall be marked as follows, or equivalent:

CAUTION: MOUNT WITH BOTTOM OF HEATER AT LEAST 2.4 m ABOVE FLOOR OR GRADE

and

ATTENTION : INSTALLER À AU MOINS 2.4 m DU PLANCHER.

5.1.19

Portable heaters having a depth (front to back) excluding projecting feet 127 mm or greater and which do not meet the test requirements for portable baseboard heaters shall be marked as follows, or equivalent:

DO NOT LOCATE AGAINST WALLS OR BEHIND DRAPES OR FURNITURE

and

NE PAS ADOSSER AU MUR OU PLACER DERRIÈRE LES RIDEAUX OU LES MEUBLES.

5.1.20

Cord-connected heaters which have power supply cords terminated in a 2-pole polarized parallel blade attachment plug of configuration 1-15P shall be marked as follows, or equivalent:

CAUTION: TO PREVENT ELECTRIC SHOCK MATCH WIDE BLADE OF PLUG TO WIDE SLOT, FULLY INSERT

and

ATTENTION : POUR ÉVITER LES CHOCS ÉLECTRIQUES, INTRODUIRE LA LAME LA PLUS LARGE DE LA FICHE DANS LA BORNE CORRESPONDANTE DE LA PRISE ET POUSSER JUSQU'AU FOND.

Note: The words CAUTION and ATTENTION shall be in capital letters at least 2.8 mm high, with the balance of the lettering in capital letters at least 1.6 mm high.

This marking (or its equivalent) shall be provided in one of the following ways:

- (a) on a tag attached to the cord adjacent to the attachment plug;
- (b) on a hand tag; or
- (c) on instructions which accompany the heater at the time of sale.

5.1.21

Cord-connected heaters employing visible glowing heater elements, where the visible portion of the element attains a temperature of at least 650°C under normal operating conditions, shall be permanently marked with the following or equivalent wording:

WARNING: RISK OF FIRE-KEEP COMBUSTIBLE MATERIAL AWAY FROM FRONT OF HEATER

and

AVERTISSEMENT : RISQUE D'INCENDIE-NE LAISSEZ PAS DE MATERIAU COMBUSTIBLE DEVANT LE RADIATEUR.

5.1.22

Cord-connected heaters provided with the supporting feet or stand detached shall be marked as follows, or equivalent:

CAUTION: ATTACH FEET BEFORE USING

and

ATTENTION : FIXER LES PIEDS AVANT D'UTILISER.

5.1.23

Cord-connected heaters provided with collapsible or folding feet or stand shall be marked as follows, or equivalent:

CAUTION: EXTEND OR UNFOLD LEGS BEFORE OPERATING

and

ATTENTION : ÉTENDRE OU DÉPLIER LES PATTES AVANT DE METTRE L'APPAREIL EN MARCHE.

5.2 Instruction Sheet, Carton, Tag

The containing carton, tags, or installation instructions, as may be applicable, shall include statements for products involved as specified in Clause 5.2.1.

5.2.1

Net volumes of connection boxes and volumes occupied by various accessories, stationary baseboard air-heaters, and baseboard heating systems shall be marked in cubic centimetres on instruction sheets. The volumes to be marked shall be established mathematically using the internal dimensions of the connection box with cover and the external dimensions of items or accessories which reduce the useful volume of the connection box. The published volumes shall be rounded down to two decimal places.

6. Tests

6.1 General

6.1.1

Heaters shall be investigated by subjecting a sample to the following applicable test.

6.1.1.1

Cord-connected heaters shall meet the applicable requirements of the following Clauses:

6.1

6.2, 6.2.1

6.3

6.4.1, 6.4.3, 6.4.4, 6.4.5

6.5

6.6.1, 6.6.2.1, 6.6.3, 6.6.4, 6.6.5.3 to 6.6.5.5, 6.6.5.7,

6.6.5.8, 6.6.6.1, 6.6.6.4, 6.6.6.6

6.7

6.8

6.9

6.10

6.11

6.12

6.13

6.18.

6.1.1.2

Stationary heaters shall meet the applicable requirements of the following Clauses:

6.1

6.2

6.3

6.4.1, 6.4.2, 6.4.4 to 6.4.7, 6.4.9, 6.4.10

6.5

6.6.1, 6.6.2.1, 6.6.2.3, 6.6.2.4, 6.6.3, 6.6.4, 6.6.5.1, 6.6.5.2,

6.6.5.5, 6.6.5.6, 6.6.5.8, 6.6.6.1 to 6.6.6.3, 6.6.6.5

6.7

6.8

6.9

6.10

6.11

6.12

6.18.

6.1.1.3

Stationary baseboard heaters shall meet the applicable requirements of the following Clauses:

6.1

6.2

6.3

6.4.1, 6.4.2, 6.4.4, 6.4.5, 6.4.8, 6.4.10

6.5

6.6.1, 6.6.2.1, 6.6.2.2, 6.6.3, 6.6.4, 6.6.5.1, 6.6.5.2, 6.6.5.5,

6.6.5.6, 6.6.5.8, 6.6.6.1 to 6.6.6.3, 6.6.6.5

6.7

6.8

6.9

6.10
6.11.1 to 6.11.3, 6.11.6, 6.11.9, 6.11.10, and 6.12
6.17.

6.1.1.4

Except for in-car heaters, cord-connected heaters provided with keyhole slots or equivalent means for suspension from walls shall meet the applicable requirements of the following Clauses:

6.1

6.2

6.3

6.4.1, 6.4.3, 6.4.4, 6.4.11

6.5

6.6.1, 6.6.2.1, 6.6.2.3, 6.6.3, 6.6.4, 6.6.5.3, 6.6.5.4, 6.6.5.5, 6.6.5.7, 6.6.5.8, 6.6.6.1, 6.6.6.3, 6.6.6.5, 6.7, 6.8, 6.9, 6.10, 6.11, 6.12, 6.13, 6.14.

6.1.1.5 Cord-Connected In-car Heaters

In-car heaters provided with means for mounting under the dash or side wall mounting shall be tested for the normal and abnormal temperature tests in both the fixed mounting and the free-standing portable mode. The following tests shall be conducted according to the specifications of Clauses 6.4.12, 6.4.13, 6.4.14, 6.4.15, and 6.6.7, as applicable.

6.1.1.6 Heaters with PTC Heating Elements

In addition to having to meet the applicable requirements of Clauses 6.1.1, heaters with PTC elements shall meet the applicable requirements of Clauses 6.1, 6.2.1.1, 6.6.2.1.1, 6.6.8, 6.6.9, 6.15, and 6.16.

6.1.2

Temperature-regulating controls provided as part of the heaters shall be shunted out of the circuit during the tests of Clauses 6.2, 6.4 and 6.6.

6.1.3

If the operation of a temperature-limiting control or a combination temperature-limiting and -regulating control is affected by the ambient air temperature such that a hazardous condition may result, such controls shall be shunted out of the circuit during the abnormal temperature test of Clause 6.6 unless the heater is tested in a room where the temperature is maintained at 0°C.

6.1.4

Temperature-limiting controls shall not function when set to maximum heat position during the tests of Clauses 6.2 and 6.4. The negative temperature calibration tolerance of the control shall be taken into account.

6.1.5

Controls not shunted out of the circuit shall be set at their maximum heat position during the tests of Clauses 6.2, 6.4, and 6.6.

6.2 Rating

6.2.1 Normal Rating

The input in amperes or watts to heaters at normal operating temperature under full load conditions shall not differ from the marked rating by more than +5% or -10%, when the heater is connected to a supply of rated frequency and marked rated voltage. If a voltage range is marked, the voltage of the supply circuit shall be the arithmetic mean of the two values. The rating test shall be made when the input has reached steady-state value.

6.2.1.1

Heaters having PTC heater elements shall be tested for steady-state wattage. The steady-state rating is the wattage at thermal equilibrium or after 1 h, whichever is reached first. The tolerance on the rating shall be +5% or -10% of the marked steady-state wattage rating.

The maximum steady-state wattage rating shall be determined with the ambient air free from draughts at $25 \pm 1^\circ\text{C}$ and at $0 \pm 1^\circ\text{C}$.

6.3 Test Voltage

6.3.1

The test voltage for the normal and abnormal tests shall be the nominal system voltage as specified in CSA Standard CAN3-C235, for the supply system on which the heater is intended to operate, except as required by Clauses 6.3.2 and 6.7.

6.3.2

Except for heaters with PTC elements, the test voltage during the normal and abnormal tests shall be adjusted to compensate for a heater that, when tested as specified in Clause 6.2, has a power input other than the marked input. As an example, for heaters rated at a nominal system voltage of 120 V or 240 V as specified in CSA Standard C235, the test voltage shall be adjusted to result in a power input equal to

$$W_m(120/V_m)^2 \text{ or } W_m(240/V_m)^2$$

where

W_m = the marked input watts

V_m = the marked voltage

120 and 240 represent the nominal voltages of the system on which the heater is intended to operate.

Where the marked voltage of the heater is higher than the nominal system voltage as specified in CSA Standard CAN3-C235, the power input to the heater during the normal and abnormal tests shall be equal to the marked input of the heater.

6.4 Temperature (Normal)

6.4.1

Heaters when operated under the applicable conditions of Clause 6.4 shall not produce temperatures higher than those given in Table 5.

The limiting temperature for insulating materials other than those given in Table 5 will be subject to investigation.

The limiting temperatures are based on a room temperature of 25°C. Temperature tests may be conducted at any room temperature between 10°C and 40°C, and the variation below or above 25°C shall be respectively added to or subtracted from the observed temperatures, except where the temperatures are controlled by a thermostat. Stationary baseboard heaters defined under Clause 2.1 are to be tested in an ambient temperature of $25 \pm 1^\circ\text{C}$.

Temperatures are to be measured by means of thermocouples except as stated otherwise.

Temperatures controlled by a thermostat and thereby subject to variation are to be measured at the maximum point of the cycle.

The temperature on pull-off plugs is to be measured at the centre of the cross sectional area, 3.2 mm from the heater end of the plug.

Maximum temperatures are those measured after thermal equilibrium has been obtained.

A thermocouple junction shall be secured in good thermal contact with the surface of the material whose temperature is being measured, by means of taping. Where radiating heat surface is involved, the thermocouple shall be secured by a minimum amount of cement. For high temperature metal surfaces it may be necessary to secure the thermocouples by peening, brazing or soldering.

6.4.2

Stationary wall-insert heaters, surface and recessed heaters, and recessed combination heater-light-ventilators, unless marked to indicate minimum clearance distance to combustible surfaces, shall be installed and tested at zero clearances. Several hours of continuous operation will usually be necessary to obtain maximum temperature conditions.

6.4.3

Portable heaters shall be placed on a supporting surface of pine.

6.4.4

Heaters with movable sections (eg, reflector bowl, forced air louvers) shall be tested in the position resulting in maximum temperatures in the heater.

6.4.5

Portable heaters and stationary convection-type heaters shall be located in a 90° wall angle formed by two black-painted, vertical surfaces of 9.5 mm thick plywood having such width and height that they extend not less than 610 mm beyond the physical limits of the heater. Portable heaters shall be spaced 25 mm from the walls.

6.4.6

Stationary wall-insert heaters shall be installed in an unpainted box to simulate actual installation conditions. The internal dimensions of the box shall be such that the walls fit the heater shell on all sides as close as construction permits. The flat, front surface shall extend away from the heater by at least 305 mm at the top and 152 mm on the other sides to simulate the wall surface in which the heater is intended to be installed.

6.4.7

Ceiling heaters, T-bar mounted heaters, recessed ceiling type air-heaters and recessed ceiling type air-heaters in combination with

either lighting or ventilating components or both, and heaters intended to be mounted on the wall at or near ceiling height shall be tested in a corner. The walls and ceiling shall be of black-painted 9.5 mm thick plywood. Heaters shall be as close to the corner as construction and installation of the heaters will permit, except that they may be spaced away from adjoining surfaces if marked in accordance with Clause 5.1.7. Thermal insulation having a thermal resistance of R32 RSI 5.6 shall be placed on the ceiling above heaters or over and around recessed ceiling heaters. Combination heater-light-ventilators shall be tested for various combinations of function modes to determine maximum temperatures. Manufacturer's instructions for wiring the heater-light-ventilator units to achieve the various functions will be followed.

6.4.8

Stationary baseboard heaters and baseboard systems shall be tested by assembling two heater units in the 90° wall angle described in Clause 6.4.5. Heaters shall be placed as close to the corner as construction of the heater will permit, except that for baseboard systems, if an inside-corner angle section is provided, it shall join the heaters. Control and receptacle sections, when provided, shall be placed at either end of the corner heaters and a second heater unit shall be added to each of these sections. Heaters shall be located as close to the wooden test floor as construction of the heater will permit. Hair felt 19 mm thick, 305 mm wide and extending the full length of the units shall be placed flat on the floor and pushed against the heaters and under the heaters as far back as construction will permit. A wood board 25 mm x 76 mm shall be placed on its edge against the wall on the top of the complete heating system to simulate the finished wall or trim.

The length of the individual heater units selected is not critical but a variety of lengths, including the longest, is preferable. All heater units are to have the maximum watts per linear foot.

The 19 mm hair felt is to have a nominal weight of 2.68 kg/m² with limits of 2.37 kg and 2.98 kg consisting of 100% animal hair felt. A centre reinforcement of approximately 142 g burlap shall be provided. No flame retardant materials or chemicals shall be added. A variation of the 19 mm hair felt may be 6.4 mm thick plywood 305 mm wide, on top of which is placed 12.7 mm thick hair felt pad of similar composition as the 19 mm hair felt.

Whenever pine is specified kiln-dried, clear white pine of 25.4 mm nominal thickness is required.

6.4.9

Heaters intended for installation in floors shall be placed in an unpainted, 9.5 mm thick plywood enclosure to simulate actual installation conditions. The internal dimensions of the enclosure shall be such that the walls fit the heater on the sides and bottom as close as construction will permit. The top edges shall be provided with horizontal surfaces extending away from the heater for 152 mm on all sides to simulate the floor surface around the heater.

Heaters shall be tested in a corner of the 90° wall angle described in Clause 6.4.5. Heaters shall be located as close to the corner as construction of the heaters will permit, but they may be spaced away from adjoining wall surfaces if marked in

accordance with Clause 5.1.7.

6.4.10

Stationary baseboard and wall-mounted heaters, which are provided with air intake in the bottom of the enclosure, and which are marked in accordance with Clause 5.1.14, when tested in accordance with Clause 6.4 shall be mounted the minimum distance above the wooden test floor specified by the manufacturer. A hair felt pad (see Clause 6.4.8) running the full extent of the heater shall be placed on the floor underneath the heater.

6.4.11

Cord-connected heaters provided with keyhole slots or equivalent shall be suspended from the wall so that the bottom of the heater is as close to the test floor and side wall as construction permits.

6.4.12

Heaters with air filters shall be operated as follows:

(a) heaters provided with temperature-limiting controls shall be operated with the air filter(s) blocked uniformly so that the maximum outlet air temperature is reached without the limit control device tripping;

(b) for heaters without temperature-limiting controls, the air filter(s) shall have 100% of their surface area blocked.

6.4.13

In-car heaters designed to be installed under the car dash or side wall shall be tested in an alcove formed of 19 mm thick black painted soft wood. The alcove shall be 610 mm wide, 457 mm deep, and 610 mm high. Depending on their mounting configuration, heaters shall be installed as follows:

(a) Heaters designed for mounting horizontally under the car dash shall be secured to the underside surface of the alcove top by the mounting means provided. The heaters shall be located as close to the side alcove wall as the construction of the heater and its mounting means will permit. The front face of the heater shall be recessed 100 mm from the edge of the alcove top.

(b) Heaters designed for mounting vertically on the car sides or the fire wall shall be installed in the corner of the alcove as close to the alcove sides and top as construction will permit.

Heaters that are not marked "Top" or "Bottom" or equivalent will be tested in a position to create the most severe condition. Heaters provided with permanently installed mounting brackets that permit the heater to be mounted one way only will be so tested.

Notes:

(1) In order to determine maximum normal temperatures, it may be necessary to conduct the test referred to in Item (a) with the heater installed so that the opposite side is facing the side of the alcove.

(2) To determine maximum temperatures, the position of the heater in the alcove shall be reversed.

6.4.14

Combination fixed-mounting and free-standing heaters shall be subjected to tests for both fixed installation and free-standing heaters.

6.4.15 Temperature Normal Test Criteria For In-Car Heaters

When installed and tested in accordance with the requirements for the normal temperature test, heaters shall not cycle on the temperature-limiting control. The temperature limit for the supporting or alcove surfaces shall be 90°C for all heaters.

6.5 Dielectric Strength

6.5.1

Heaters at normal operating temperature shall withstand without breakdown, for a period of 1 min, the application of an ac voltage between live parts and non-current-carrying metal parts. The test voltage shall be 1000 V for heaters rated at 300 V or less, and shall be 1000 V plus twice the rated voltage for heaters rated at more than 300 V.

6.5.2

Compliance with Clause 6.5.1 shall be determined by means of a suitable testing transformer, the output of which can be regulated. Starting at zero, the applied voltage shall be increased gradually and at a uniform rate until the required test value is reached.

6.6 Temperature (Abnormal)

6.6.1

If the conditions of normal operation are not representative also of abnormal conditions likely to occur in actual service, heaters shall not become an undue hazard when operated under such abnormal conditions. If motors are present, they shall continue to be operable upon completion of the temperature (abnormal) tests.

6.6.2 Test Criteria

6.6.2.1

When operated under abnormal conditions, heaters, except as provided in Clauses 6.6.2.2 to 6.6.2.4, shall be considered a hazard if there is

- (a) emission of flame or molten metal, excluding solder;
- (b) glowing or flaming of test material or supporting or adjacent surfaces;

Note: Glowing of cheesecloth is to be determined by visual examination for broken fibres after removing cheesecloth from heater.

- (c) short-circuiting of the heating element either between turns, between sections, or to non-current-carrying metal parts;
- (d) deformation of nonmetallic parts or enclosure which will prevent the heater from meeting the requirements of Clause 4.2.6;
- or
- (e) short-circuiting of motor windings.

6.6.2.1.1

In addition to the requirements specified in Clause 6.6.2.1, when heaters with PTC heater elements are operated as specified in Clauses 6.6.8 and 6.6.9, the ampacity of the field supply conductors or power supply cord sets shall not exceed the values

specified in the CSA Standard C22.1.

6.6.2.2

When operated under the applicable abnormal conditions of Clause 6.6.6, stationary baseboard heaters, except those marked in accordance with Clause 5.1.12, shall be considered a hazard if the tests result in

- (a) conditions of Item (a), (c), (d), or (e) of Clause 6.6.2.1;
- (b) discolouration of the test materials used; or
- (c) temperatures exceeding 150°C in the materials or on the supporting or adjacent surfaces.

With reference to Clause 6.6.2.2(c) a maximum temperature of 179°C will be allowed during the initial period of five cycles of operation of the temperature-limiting control, or 2 h, whichever comes first. Thereafter maximum temperatures shall not exceed 150°C.

6.6.2.3

When operated under the abnormal conditions of Clause 6.6.6, stationary wall-mounted heaters, cord-connected heaters provided with keyhole slots or the equivalent for suspension from walls, free-standing cabinet types (except those intended for high level installation) that are not marked in accordance with Clause 5.1.10, and baseboard types that bear the marking of Clause 5.1.12, shall be considered a hazard if the tests result in

- (a) conditions of Item (a), (c), (d), or (e) of Clause 6.6.2.1; or
- (b) charring of the supporting surfaces, adjacent wall or floor surfaces, or the test materials.

Note: Charring is more than discolouration; it is the condition where the surface or test material is black.

6.6.2.4

Stationary wall-mounted heaters marked in accordance with Clause 5.1.10, when operated under the abnormal conditions of Clause 6.6.5.2, shall be considered a hazard if the tests result in

- (a) the conditions of Item (a), (c), (d), or (e) of Clause 6.6.2.1; or
- (b) charring of the supporting surfaces, adjacent wall or floor surfaces, or the test materials.

Note: Charring is more than discolouration; it is the condition where the surface or test material is black.

6.6.2.5

To determine whether a fire hazard actually exists, an abnormal heating test shall be conducted with heaters operating continuously until the ultimate result has been determined.

The following conditions shall be met:

- (a) Unless otherwise specified heaters shall be located or supported as for the normal temperature test; and
- (b) If draping is required
 - (i) the test shall be started with the heater at room temperature and with the heater draped;
 - (ii) the heater in Item (i) shall be operated without draping until constant temperatures are obtained and then draped with the test materials.

6.6.3

Stationary and portable baseboard heaters, when operated under the abnormal conditions specified in Clause 6.6.6.7, shall be considered a hazard, if the test results in

- (a) the conditions described in Items (a), (b), (c), (d), and (e) of Clause 6.6.2.1;
- (b) glowing or flaming of the (dry shredded newspaper) test materials.

6.6.4 Test Materials for Abnormal Tests

The draping materials and cloths to be used for the abnormal tests of Clause 6.6 shall be as follows:

- (a) cheesecloth to consist of bleached cheesecloth running 25.8 to 27.6 m²/kg, and having a thread count of 32 by 28;
- (b) white duck weighing 406 gm/m² and
- (c) hair felt approximately 25 mm thick, weighing 3.05 kg to 3.56 kg nominal 3.56 kg/m², consisting of 100% animal hair and with a centre reinforcement of approximately 141 g of burlap; no flame retardant materials or chemicals shall be added.

6.6.5 Abnormal Test Conditions

6.6.5.1

Stationary heaters other than those covered by Clauses 6.6.5.2 and 6.6.5.6 shall be loosely covered with two layers of cheesecloth. This shall not apply to heaters intended for ceiling installation or otherwise isolated by elevation.

6.6.5.2

Stationary heaters intended for installation in or on walls and marked in accordance with Clause 5.1.10 shall be tested as follows:

- (a) two layers of cheesecloth shall be suspended from the wall 305 mm above the heater and allowed to drape the entire front face of the heater;
- (b) a simulated drape consisting of white duck with two layers of cheesecloth lining the duck on the side facing the heater shall be suspended from a vertical wall 305 mm above the heater. During the test the drape shall be made to conform to the general contour of the heater. To produce maximum temperature conditions the width of the drape or drapes, if two or more separate widths are deemed necessary, may be varied.*

**This test does not apply to wall-mounted heaters marked in accordance with Clause 5.1.18.*

6.6.5.3

(a) Portable heaters shall be overturned in any position on a surface of pine covered with two layers of cheesecloth. Heaters shall be operated under the most severe conditions that result when they come to rest, without further guiding or propping, after being overturned.

(b) In-car heaters, whether free-standing type or of the type designed for fixed installations, shall be overturned or placed face down on a surface of 2 cm thick pine board covered with 2.54 cm thick hair felt and a double layer of cheesecloth. Heaters shall be operated under the most severe conditions that result when they come to rest, without further guiding or

propping.

6.6.5.4

Portable heaters shall be placed so that their radiated heat is directed against a vertical surface of pine wider than the heater covered with two layers of cheesecloth and located at the distance from the heater resulting in maximum temperatures. The vertical wood surface shall abut the horizontal wood surface supporting the heater, except that when testing heaters with projecting feet that extend beyond the front face of the heater, the vertical surface shall be raised above the supporting surface sufficiently to permit the feet to extend under the vertical surface.

Note: The pine boards used shall be 19 mm thick and shall be free of any knots.

6.6.5.5

Heaters having motor-driven fans shall be operated with the fan motor stalled and without cheesecloth covering the heaters.

6.6.5.6

Floor-insert heaters and heaters having air discharge through the enclosure top shall be tested by placing flat on top of the heater the test materials specified in Clauses 6.6.6.3(b) and 6.6.6.5. The test materials shall be of such dimensions that maximum temperatures are produced. Both the air intake and the air exhaust sections of the heater may be restricted. The test criteria shall be as outlined in Clause 6.6.2.3.

6.6.5.7

Portable heaters, except portable baseboard heaters, shall be tested while draped loosely with six layers of cheesecloth to determine whether the heater complies with the requirements of Clause 6.6.2.1(a), (b), (c), (d), and (e). The test shall be conducted as follows:

- (a) the test shall be started with the heater at room temperature and with the heater draped; and
- (b) the heater shall be operated without draping until constant temperatures are obtained and then draped with the cheesecloth.

6.6.5.8

Heaters with an air filter shall be tested with the filter(s) sufficiently blocked to produce maximum abnormal conditions. This test may be omitted if the furniture restriction test of Clause 6.6.6.5 simulates a blocked filter test.

6.6.6 Stationary and Portable Baseboard Heaters and Wall-Mounted Heaters (Tests Under Abnormal Conditions)

6.6.6.1 General

Stationary and portable baseboard heaters, cord-connected heaters provided with keyhole slots or equivalent, and stationary wall-mounted heaters not marked in accordance with Clause 5.1.10, shall be subjected to the applicable tests of Clauses 6.6.6.3 to 6.6.6.5 and 6.6.6.7.

6.6.6.2

Temperatures in the test materials of stationary baseboard heaters (see Clause 6.6.2.2) shall be measured by means of thermocouples

having wires of No. 30 AWG. The thermocouple junctions shall be welded. The junctions shall be placed between the 2 layers of cheesecloth used in the tests.

6.6.6.3 Drape Tests

Heaters, except portable baseboard heaters, shall be subjected to the following tests for a maximum duration of 7 h:

- (a) two layers of cheesecloth shall be suspended from the wall 305 mm above the heater. The drape shall be made to conform to the general contour of the heater and the lower edge of the drape shall just touch the floor;
- (b) a simulated drape consisting of white duck with two layers of cheesecloth lining the duck on the side facing the heater, shall be suspended from a vertical wall 305 mm above the heater. The drape shall be made to conform to the general contour of the heater, and the lower edge of the drape shall just touch the floor. To produce maximum temperature conditions, the width of the drape or drapes, if two or more separate widths are deemed necessary, may be varied, but in no case shall the sections of drapes be less than 305 mm wide.

6.6.6.4

The drape test for portable baseboard heaters shall be as described in Clause 6.6.6.3, except that such heaters shall be installed as required by Clause 6.4.5, and the specified test materials shall be draped over the heater front, top, and back.

6.6.6.5 Furniture Restriction Test

Heaters shall be tested by placing a vertical surface as close to the front of the heater as construction of the heater will permit. The vertical surface shall

- (a) be plywood 9.5 mm thick covered by a hair felt pad 25 mm thick (see Clause 6.6.4(c)), with the hair felt in turn covered by two layers of cheesecloth;
- (b) rise to a height of 76 mm above the top of the heater;
- (c) have a length such that maximum temperature conditions are produced, except that a length less than 305 mm and greater than 1.8 m shall not be used. If the heater is provided with some form of temperature-limiting device, the length and the location of the vertical surface shall be varied to be certain that maximum temperature conditions have been observed;
- (d) rest on the hair felt pad, which simulates a rug; except that for heaters having supporting feet extending beyond the front face of the heater, the test wall shall be raised sufficiently above the horizontal supporting surface to clear the heater feet; and
- (e) not press against the face of the heater but merely touch the heater.

6.6.6.6

The furniture restriction test for portable baseboard heaters shall be as described in Clause 6.6.6.5, except that such heaters shall be installed as required by Clause 6.4.5.

6.6.6.7 Shredded Paper Test

Stationary and portable baseboard heaters that do not comply with the guarding requirements of Clause 4.2.8.14 shall be tested as follows:

- (a) the heaters shall be installed and operated as in the normal

temperature test;

(b) while in operation, dry shredded newspaper (approximately 6.4 mm wide in various lengths) shall be introduced in any quantity and position in the unguarded slots to attain the most adverse conditions; and

(c) this test shall have a maximum duration of 7 h.

6.6.7 Abnormal Temperature Tests for In-car Heaters

All in-car heaters, including those designed for fixed installation only, shall be subjected to all the abnormal temperature tests required for portable heaters as follows:

- (a) Clause 6.6.5.3 (overturn test);
- (b) Clause 6.6.5.4 (vertical wall tests);
- (c) Clause 6.6.5.5 (stalled fan motor test), and
- (d) Clause 6.6.5.7 (cheesecloth draped test).

6.6.8 Abnormal Input for Heaters with PTC Elements

Heaters using PTC heater elements shall be conditioned for 4 h at -20°C . The heater shall then be connected to marked supply voltage and shall be operated at -20°C until steady-state is reached, at which time the input in amperes shall be measured.

6.6.9 Cold Ambient Start Up for Cord-Connected Heaters with PTC Elements

6.6.9.1

The heater shall be conditioned for 4 h at -20°C and then tested in accordance with Clauses 6.6.9.2 to 6.6.9.5.

6.6.9.2

A heater shall start and run without blowing the branch circuit fuse for which it is designed to be used.

6.6.9.3

The heater and four non-time-delay plug fuses shall be connected in series. The fuses shall have the same rating as the attachment-plug cap of the supply cord and may be selected to be representative of fuses likely to be encountered in service. Fuses shall be located in a 25°C ambient.

6.6.9.4

The heater shall be energized while in -20°C ambient.

6.6.9.5

If no fuse blows, the size used is proper for starting the unit. If one fuse blows, the test shall be repeated, using the three remaining fuses. Sufficient time shall be allowed for the heater to return to -20°C before repeating the test.

If none of the three fuses blows, the fuse size is acceptable. If one of the three blows, the fuse size is not acceptable and the test shall be repeated, using four time-delay fuses of the same rating. The proper size of fuse necessary for starting the device is to be selected only after the device has successfully started and restarted in series with that fuse size.

6.6.10 Starting

6.6.10.1

Heaters using PTC heater elements shall be tested as per Clauses 6.6.8 and 6.6.9, but at 0°C ambient.

6.6.10.2

To determine compliance with Clause 6.6.10, the heater shall be connected to a supply circuit of the nominal system voltage and shall start without cycling any temperature limiting or any steady state overcurrent protective device provided as part of the heater.

6.7 Extreme Operating Voltage (Maximum Test

6.7.1

Heaters tested in accordance with Clauses 6.7.2 and 6.7.3 shall not become a hazard as defined in Clause 6.7.4.

6.7.2

Heaters shall be installed in accordance with the applicable requirements of Clauses 6.4.2 to 6.4.10.

6.7.3

To determine whether a hazard exists, the supply voltage to the heater shall be adjusted as required by Clause 6.3 and the heater operated until temperatures become stable. The supply voltage shall then be adjusted to the maximum of the extreme operating voltage as given in CSA Standard CAN3-C235, for 2 h.

6.7.4

When operated under the maximum extreme operating voltage, heaters shall be considered to be a hazard if there is

- (a) emission of flame or molten metal, excluding solder;
- (b) glowing or flaming of test material or supporting or adjacent surfaces;
- (c) short-circuiting of the heating element either between turns, between sections, or to non-current-carrying metal parts;
- (d) deformation of nonmetallic parts or enclosure which will prevent the heater from meeting the requirements of Clause 4.2.6; or
- (e) short-circuiting of motor windings.

6.8 Strain Relief

The strain relief for a power supply cord shall prevent transmission of strain to interior wiring, splices, or terminals when:

- (a) a steady pull of 89 N is applied in any direction for 1 min; and
- (b) the cord is pushed in, in which case the cord shall be prevented from contacting sharp edges, points or moving parts, or from being exposed to temperatures above the temperature rating of the cord insulation.

6.9 Overload and Endurance--Manually Operated Switches

6.9.1

Switches shall be the subject of investigation regarding the necessity of applying the following overload and endurance tests. In general, the endurance test may be omitted for cord-connected heaters.

6.9.2 Overload (Heater Only)

6.9.2.1

Switches shall be capable of performing 50 operations of making and breaking the heater current with the heater connected to a supply circuit having a voltage equal to 110% of the rated voltage of the heater. The cycling rate shall not be faster than six times per minute. As an alternative, controls may be tested separately from the heater, provided that the same voltage and current values are used. There shall be no electrical or mechanical failure of the switches, nor any undue burning, pitting, or welding of the contacts.

6.9.2.2

In the test of Clause 6.9.2.1, that pole of switches which is least liable to arc to grounded metal parts shall be connected to such parts through a suitable 3 A fuse. Under this condition, flashover to the grounded metal parts shall not occur.

More explicitly, the connection of the switch pole is as follows:

- (a) for single-pole switches connected to single-phase circuits, the supply line opposite to that passing through the switch shall be connected to grounded metal parts; and
- (b) for double-pole switches connected to single-phase circuits, the connection shall be as given in Item (a). However, if it is difficult to ascertain visually which pole is least liable to arc to grounded metal parts, 25 operations per pole shall be made, the opposite pole in each instance being connected to the grounded metal parts.

6.9.3 Overload (Motor and Heater)

6.9.3.1

Switches shall be tested at the maximum rated voltage and lowest rated frequency by making and breaking the stalled motor current 50 consecutive times without undue arcing, burning, pitting or welding of their contacts, and without either electrical or mechanical failure. If, in addition to the motor, a heating element is controlled by the switch, it shall be included in the test.

Note: For motors of the shaded-pole type where the motor current is small compared with the heating element current, the test of Clause 6.9.2.1 will be performed rather than that of Clause 6.9.3.1.

6.9.3.2

In performing the test of Clause 6.9.3.1, the duration of the OFF period shall be such that the temperature rise of the windings does not exceed that normally encountered in service, but in no case shall the switch be operated at a rate faster than 10 times

per minute. The connections for the grounding lead shall comply with the requirements of Clause 6.9.2.2.

6.9.3.3

If a universal motor is involved, the dc overload test shall be considered representative of the test for ac. In the event that the switch fails to pass the dc test, but passes the ac test, the heaters shall be marked for ac only, unless a switch suitable for both ac and dc is substituted.

6.9.4 Endurance (Heater Only)

Switches for the control of heating elements shall be tested at the test voltage (and lowest rated frequency if for ac) by making and breaking the maximum current which they control in the heater 1000 consecutive times at a rate not faster than 10 times per minute without undue arcing, burning, pitting, or welding of their contacts, and without either electrical or mechanical failure.

6.9.5 Endurance (Motor and Heater)

Switches for the control of motor circuits shall be tested at the test voltage (and lowest rated frequency if for ac) by making and breaking the motor current 1000 consecutive times at a rate not faster than 10 times per minute without undue arcing, burning, pitting, or welding of their contacts, and without either electrical or mechanical failure. If in addition to the motor a heating element is controlled by the switch, it shall be included in the circuit.

6.10 Performance of Fusible Links

6.10.1

If fusible links are provided in heaters to prevent the attainment of excessive temperatures during abnormal operation, the links shall open the circuit as described in Clause 6.10.2 without short-circuiting of live parts, grounding of live parts to enclosure or other non-current-carrying conductive parts, or other hazardous condition.

6.10.2

To determine if the operation of a fusible link complies with the requirements of Clause 6.10.1, five fusible links shall be caused to operate in the heater by increasing the supply voltage, by blanketing the heater, or by a combination of both.

6.11 Physical Abuse Tests

6.11.1 General

Heaters with nonmetallic enclosures and/or nonmetallic guards shall withstand an impact test on any exposed surface of 2.0 N·m from a steel sphere having a mass of approximately 0.54 kg. The steel sphere shall be dropped through an arc to strike a vertical surface or shall be dropped vertically to strike a horizontal surface with the specified impact. During this impact test the heater shall be held in a fixed position on a supporting surface. The impact test shall be repeated at two other locations on the same unit. The tests shall be performed while the unit is at a temperature of $-30 \pm 2^{\circ}\text{C}$.

6.11.2

Radiant panel heaters other than those intended for ceiling installation shall not show signs of failure by developing openings or cracks when the heater is subjected to the following impact test.

With the guard in place if such is provided, panels shall be capable of withstanding, at any point on the surface of the panel or guard, a single impact of 2.0 N·m from a steel sphere having a mass of approximately 0.54 kg. The sphere shall be suspended by a fine wire and allowed to fall as a pendulum through the distance required to produce the specified impact, and the heater shall be placed so that the panel or guard to be tested is vertical and the point of support of the pendulum is 25.4 mm in front of the vertical plane of the panel or guard.

6.11.3

Radiant panel heaters, with or without guards, shall not show signs of failure by developing openings or cracks when a cloth wet with cold tap water is moved over the surface of the panel to simulate cleaning.

6.11.4

Nonmetallic enclosure material, which may be susceptible to the effects of thermal shock, shall withstand a wet cloth fully saturated with water at room temperature wiped across the surface while the heater is at its normal operating temperature.

6.11.5

The register of a floor-insert heater shall withstand a static load or force of 1334 N applied to a surface area of 929 cm² at the centre of the register without permanent deflection or distortion of the heater and its support that results in reduction of the spacings required by Clause 4.18.

6.11.6

A floor insert heater as initially received shall be energized and allowed to reach operating temperature. A cotton mop of nominal 0.45 kg size shall be fully immersed in water for 5 min and immediately upon withdrawal from the water the mop shall be swabbed five times across the heater's grill. The heater shall withstand the dielectric strength test of Clause 6.5 before and after this test.

6.11.7

As a result of the tests in Clauses 6.11.1 to 6.11.6, there shall be no fracture that exposes live parts to the probe specified in Clause 4.2.6.1, reduction in spacings, or leakage current for cord-connected heaters exceeding the requirements set by Clause 6.13.

6.12 Flame Test for Nonmetallic (Polymeric) Enclosures and Supports

6.12.1

Nonmetallic (polymeric) enclosures and supports shall comply with the requirements of Flame Test A of CSA Standard C22.2 NO. 0.6. The test shall be performed on the minimum thickness and colour of the sample enclosure.

6.12.1.1

At the completion of the flame test of Clause 6.12.1, any resulting openings in the material shall meet the probe test of Clause 4.2.6 after the material has cooled to normal temperature. The probe shall be applied without force.

6.12.2

Nonmetallic enclosures and supports having flame retardant coatings, liners, or coverings shall comply with the requirements of Flame Test J of CSA Standard C22.2 No. 0.6.

6.13 Leakage Current

6.13.1

The leakage current for single-phase, cord-connected heaters intended for connection to a nominal supply voltage of 120 V shall not exceed 0.5 mA when tested in accordance with the test conditions in Clauses 6.13.2 to 6.13.9, except that heaters having sheathed heater elements may have 4 mA leakage current for the first 10 min after power is first applied but shall not exceed 0.5 mA leakage current after the 10 min interval.

6.13.2

The meter may be electronic or a direct indicating type, average responding, calibrated at 60 Hz and indicating the rms value of a pure sine wave, with an accuracy of 5% at an indication of 0.5 mA. The meter shall have a terminal impedance of 1500 Ω shunted by a 0.15 mF capacitor.

6.13.3

The test frequency shall be 60 Hz.

6.13.4

The applied voltage shall be 120 V.

6.13.5

The test circuit shall be as shown in Figure 2.

6.13.6

The appliance shall be at room temperature with all appliance switches in the ON position and S1 switch open and also tested within 5 s of applying the test voltage (switch S1 closed) and again after reaching normal operating temperatures. Equipment with speed or temperature controls shall be tested at low, medium and high settings of the controls.

6.13.7

The grounding conductor of cord-connected equipment having a grounding circuit shall not be connected to ground.

6.13.8

The probe shall be of metal with an insulating handle; and if an insulating material is used for part, or all of the enclosure, the probe shall contact metal foil 100 x 200 mm in area in contact with the accessible surface. Where the surface area of the enclosure is less than 207 cm², the metal foil area shall be reduced to the same area.

6.13.9

The tests shall be conducted with the switch S2 in position A, and repeated with the switch in position B.

6.14 Performance of Thermally Operated Controls

6.14.1 General

6.14.1.1

The following overload and endurance tests shall be performed with controls at the maximum temperature that they will be subjected to in the heater.

6.14.1.2

If a thermally operated control is used in conjunction with a magnetic contactor or other auxiliary equipment, the tests of Clause 6.14 shall be conducted on the combination of thermostat and contactor functioning as a unit.

6.14.1.3

The performance of automatic reset temperature-limiting control for stationary baseboard heaters shall be determined by subjecting each of four representative samples to the tests of Clauses 6.14.2.2, 6.14.3, 6.14.4.4, and 6.14.5, unless continuous operation of the heaters with the thermostat shorted out of the circuit would not result in the hazard described in Clause 6.6.2.2.

6.14.2 Calibration

6.14.2.1

The maximum cut-off temperature of thermally operated controls, other than temperature-limiting controls for stationary baseboard heaters, shall be measured at the beginning and at the end of the tests, and it shall not have changed by more than +10°C or -20°C.

6.14.2.2

The maximum cut-off temperature of temperature-limiting controls for stationary baseboard heaters, as measured in the recalibration test (see Clause 6.14.5), shall be not more than 5°C higher than the cut-off temperature measured before any tests have been conducted.

6.14.3 Overload

6.14.3.1

Controls for regulating or limiting the temperature of heaters shall be capable of performing 50 cycles of operation with the heater connected to a supply circuit having a voltage equal to 120% of the rated voltage of the heater. As an alternative, controls may be tested separately from the heater, provided that the same voltage and current values are used. There shall be no electrical or mechanical failure of the controls, nor any undue burning, pitting, or welding of the contacts.

6.14.3.2

In determining compliance of controls with the requirement of Clause 6.14.3.1, connection of the switch poles shall be as described in Clause 6.9.2.2.

6.14.4 Endurance

6.14.4.1

Thermally operated controls shall be capable of withstanding an endurance test consisting of the number of cycles specified in Table 6. The thermostats shall make and break, at the test voltage, the maximum current that they control in the heater. There shall be no electrical or mechanical failure and no undue burning, pitting, or welding of the contacts.

6.14.4.2

For heaters that use a liquid as a heat exchange medium, the endurance test shall consist of a minimum of 100 000 cycles of operation, unless continuous operation with the automatic control shorted out of the circuit would not produce any hazardous condition.

6.14.4.3

In the determination of compliance of a control with the tests of Clause 6.14.4.1, the connection of the switch poles shall be as described in Clause 6.9.2.2.

6.14.4.4

Temperature-limiting controls for stationary baseboard heaters shall be subjected to 100 000 cycles of operation, at a rate not exceeding 10 cycles per minute, making and breaking the maximum current to be controlled at the applicable test voltage of Clause 6.3.

6.14.5 Conditioning and Recalibration (Temperature-Limiting Controls for Stationary Baseboard Heaters)

Following the endurance test of Clause 6.14.4.4, temperature-limiting controls shall be maintained for 1 h at a temperature of 0°C and then maintained for 1 h at the maximum temperature to which the controls are intended to be subjected in use. The cut-off temperature shall then be determined and shall be in accordance with Clause 6.14.2.2.

6.15 Performance of Heaters Having PTC Heater Elements

6.15.1 General

6.15.1.1

Two samples of heaters having PTC heater elements shall be subjected to the tests in Clause 6.15.1.3.

6.15.1.2

During or upon completion of the test in Clause 6.15.1.3, the samples shall be examined for cracking, shorting, or opening of the PTC heating element. The occurrence of any of these shall constitute failure.

6.15.1.3

One sample shall be subjected to the tests in Clause 6.15.2.

The second sample shall be subjected to the tests in Clauses 6.15.3 to 6.15.6 inclusive, in that order.

6.15.1.4

The tests shall be performed on the completely assembled heater.

The tests in Clauses 6.15.2 to 6.15.5 inclusive shall be performed on the PTC heater element alone or on the completely assembled heater. Factors to be considered may include the type of construction of the electrical contacts of the PTC heater element and the degree of exposure to air of the PTC heating element (potted versus unpotted, etc).

6.15.1.5

The operating tests of Clauses 6.15.2, 6.15.3, and 6.15.4 shall be performed at the extreme operating conditions specified in CSA Standard CAN3-C235.

6.15.2 Thermal Cycling

The PTC heater element resistance shall first be measured.

Following measurement of the PTC heater element resistance, the heater elements shall be thermally cycled in a room ambient of $25 \pm 5^\circ\text{C}$ or at some other ambient that is based on the design ambient of the heater. The method of measuring resistance and the test ambient shall be agreed to by both the manufacturer and the testing agency.

The voltage applied will be 120% of the test voltage specified. During the first cycle the peak current shall be noted and the cycle continued until the current is reduced to 50% of the peak current, at which point the power to the heater shall be switched off. The heater shall be forced air cooled until the measured resistance of the PTC heater element returns to within 5% of the initially measured resistance and the elapsed time noted. At this point the forced air cooling shall be discontinued and power reapplied. Together, the power ON and forced air cooling period constitute one cycle.

The PTC heater element shall withstand 50 000 cycles.

6.15.3 Humidity Conditioning

The sample described in Clause 6.15.1.4 shall be conditioned in an atmosphere controlled at 95-100% relative humidity at 60°C for 7 days.

6.15.4 Low-Temperature Cycling

The sample described in Clause 6.15.1.4 shall be conditioned in an atmosphere controlled at -30°C for 24 h, with the equipment energized in cycles consisting of 15 min ON followed by 15 min OFF.

6.15.5 Hot-Cold Conditioning

The sample described in Clause 6.15.1.4 shall be conditioned unenergized as follows:

- (a) 48 h at 60°C and normal relative humidity;
- (b) 48 h at 40°C and 85-90% relative humidity;
- (c) 8 h at -30°C and normal relative humidity; and
- (d) 64 h at 40°C and 85-90% relative humidity.

6.15.6 Vibration

Only PTC heater elements with pressure-type contacts shall be subjected to this test. The PTC heater element shall be subjected for 1 h to a vibration of 1.5 kg, peak amplitude 0.20 mm at 60 cycles/s. The vibration shall be parallel to the face of the PTC heating element and at right angles to the face of the PTC heating element for equal periods of time. The PTC heater element shall not be energized and the ambient air shall be at $25 \pm 2^\circ$

6.16 Hydrostatic Test

6.16.1

To determine compliance with Clause 4.12.7, each sample of the vessel or part shall be subjected to a hydrostatic test as follows:

With the pressure relief valve, if provided, made inoperative, each sample shall be so filled with water as to exclude air, and shall be connected to a hydrostatic pump. The pressure shall be raised gradually to the specified test value as determined in Clause 4.12.7.2 and held at that value for 1 min. The results are not acceptable if the sample either bursts or leaks, except in the case where provision has been made as described in Clause 4.12.7.5. If there is a leakage at a gasket during the hydrostatic pressure test, the test shall not be considered to signify a failure unless the leakage occurs at a pressure 40% or less of the required test value.

6.16.2 Fusible Plugs

Three sample fusible plugs of each size and temperature rating shall be tested as follows:

- (a) The test sample shall be attached to coiled copper tubing not less than 3.0 m long within which air pressure not less than 276 kPa gauge is maintained;
- (b) The coil and test sample shall be immersed in a fluid (eg, air) the temperature of which is 10 K below the marked temperature of the plug; and
- (c) After an interval of 5 min, the temperature of the fluid shall be raised at a rate of 0.5 K/min. until blowout occurs.

The relief temperature shall be considered to be that temperature at which complete blowout of the fusible element occurs.

6.17 Dropping Melted Particles Test

As required by Clause 4.2.6.8.5(c), perforated metal panels or wire screens shall be tested as follows:

- (a) A sample of the connection box and screen shall be securely supported in a horizontal position 63.5 mm above a horizontal firebrick or other nonflammable surface located under a hood or in another area that is well ventilated;
- (b) Bleached cheesecloth running 26.6 to 27.6 m²/kg and having what is known in the trade as a count of 32 x 26 shall be placed in two layers on the nonflammable surface, covering somewhat more area than that immediately under the pattern of openings in the sample; and
- (c) A bare 305 mm length of No. 12 AWG solid copper wire and a 305 mm length of No. 12 AWG stranded copper wire insulated with 0.80 mm of PVC shall be melted simultaneously at an even rate, using an oxy acetylene torch, for 25.4 mm along the length of the

wires. The test shall begin with the wires held in parallel position and fixed in a horizontal plane, and the melting wires shall be allowed to drip from a point 152 mm above the pattern of openings in the sample.

There shall be no ignition of the cheesecloth.

6.18 Stability

As required by Clause 4.20, free-standing heaters shall be tested for stability while operating or when placed in any position on a slope of 10° to the horizontal. The heater shall not overheat while operating or placed in any position as a result of this test.

7. Requirements for Cord-Connected Double-Insulated Electric Air-Heaters

7.1 Scope

7.1.1

This Clause is supplementary to, or mandatory of, those requirements given elsewhere in this Standard and forms the basis for the design and construction of cord-connected electric air-heaters that have double-insulation in lieu of the grounding of exposed non-current-carrying metal parts, if any, and are marked to indicate this in accordance with Clause 7.5.

7.1.2

These requirements shall apply to equipment for use in ordinary locations on circuits not exceeding 150 volts-to-ground and designed to be used in accordance with the Rules of the *Canadian Electrical Code, Part I*.

7.2 Definitions

The following definitions apply in this Standard for the purposes of these requirements:

Basic insulation--insulation applied to bare live parts in order to separate them from nonaccessible non-current-carrying metal parts, or from supplementary insulation, or from both.

Double-insulated equipment--equipment in which double insulation is used throughout, except for parts where, because double insulation is manifestly impracticable, reinforced insulation is used.

Note: *Insulating material may form a part or the whole of the enclosure of double-insulated equipment.*

Double insulation--an insulation system comprised of both basic insulation and supplementary insulation, with the two insulations physically separate and so arranged that they are not simultaneously subjected to the same deteriorating influences (eg, temperature, contaminants, etc) to the same degree.

Reinforced insulation--an improved functional insulation with such

mechanical and electrical qualities that it provides the same degree of protection against electric shock as double insulation.
Note: *An enclosure of insulating material may form a part or the whole of the reinforced insulation.*

Supplementary insulation--an insulation provided in addition to the functional insulation in order to ensure protection against electric shock in case of failure of the functional insulation.
Note: *An enclosure of insulating material may form a part or the whole of the supplementary insulation.*

7.3 General Requirements

7.3.1

The construction shall be such that failure of two independent sections of insulation must occur before any exposed metal can become alive, unless the construction is such that reinforced insulation is acceptable (see definition of double-insulated equipment).

7.3.2

Reinforced insulation shall be used only when it is manifestly impracticable to use double insulation.

7.3.3

Supplementary insulation shall provide insulating and mechanical properties not less than those of the basic insulation normally acceptable for the equipment.

7.3.4

Where part or the whole of the enclosure is of insulating material (ie, there are no exposed conductive parts), it shall be treated as supplementary or reinforced insulation as applicable.

7.3.5

Basic insulation and non-current-carrying conductive parts insulated from bare live parts by basic insulation shall not be accessible to the user, as described by Clause 7.4.2.2.

7.3.6

Capacitors shall not be connected to exposed metal parts.

7.3.7

The construction shall be such that normal use of the equipment, including servicing, will not result in loss of insulation as originally provided.

7.4 Construction

7.4.1 General

7.4.1.1

Except where reinforced insulation is used, supplementary insulation shall be interposed between all exposed non-current-carrying conductive parts and

- (a) basic insulated current-carrying parts including insulated wire; and
- (b) all non-current-carrying conductive parts that are separated

from bare current-carrying parts by basic insulation.

Note: A permanently maintained air space may be accepted as either supplementary or reinforced insulation.

7.4.1.2

External parts of insulating material, the deterioration of which might cause the heater to become unsafe, shall be sufficiently resistant to heat (see Clause 6.13).

7.4.1.3

The construction shall be such that the added protection provided by a supplementary insulation will not be reduced by the normal use, reasonable abuse, and normal servicing to which the equipment is liable to be subjected.

7.4.1.4

Unless protected from physical abuse by the outer enclosure of the equipment or by other means, supplementary insulation shall be adequately resistant to such abuse.

Note: Supplementary insulation that comprises the outer enclosure of the equipment is considered to be adequately resistant to physical abuse if the equipment complies with the requirements of the impact test of Clause 6.11.1 or 6.11.2, as applicable.

7.4.1.5

All bare live parts of a switch, other than its terminals, shall be completely enclosed in a separate enclosure of insulating material, and

- (a) no non-current-carrying conductive part which extends outside the switch enclosure shall enter the arc chamber;
- (b) the plunger, toggle or similar part that comes into contact with bare live parts shall be wholly of insulating material; and
- (c) with the exposed external parts of the plunger, toggle or the like removed, no bare live parts inside the switch enclosure shall be accessible, as determined by the rod test of Clause 7.4.2.2.

7.4.1.6

The ON-OFF control switch shall result in disconnecting all supply conductors of the circuit controlled when in the OFF position.

7.4.2 Openings and Recesses

7.4.2.1

There shall be no openings other than those which are required for the proper functioning of the equipment, including the dissipation of the heat generated during its normal operation.

7.4.2.2

Any openings or recesses giving access to bare live parts, basic insulated parts, or basic insulation shall be of such size or shape that they prevent the entry of a straight rod of circular cross section 6.4 mm in diameter.

Note: Magnet (eg, film-coated) wire is considered to be a bare live part for purposes of this requirement.

7.4.2.3

All openings, including construction joints, shall be designed so

as to minimize the accumulation of dirt, dust, hair, etc, which could cause bridging or serious contamination of insulating surfaces.

7.4.3 Mechanical Assembly

7.4.3.1

Bare live parts shall be constructed and secured so that, in normal use, they cannot come in contact with supplementary insulation or any non-current-carrying conductive parts which are separated from external conductive parts by only supplementary insulation. The construction shall be such that any air gap between such parts cannot be reduced below the value permitted or be bridged by foreign matter.

Note: Magnet (eg, film-coated) wire is considered to be a bare live part for the purposes of this requirement.

7.4.3.2

The construction shall be such that it will prevent any wires, screws, nuts, washers, springs, and similar parts that might become loose or free from bridging any supplementary or reinforced insulation. Only one part shall be considered as loosening or becoming free at any one time.

7.4.3.3

Sleeves, if provided as supplementary insulation on insulated conductors, shall be secured in position so that they cannot be accidentally removed (eg, during servicing).

7.4.3.4

An accessible brush cap shall be

- (a) of suitable insulating material; and
- (b) recessed so that its top is behind the plane of the brushholder opening in the surrounding portion of the enclosure of the equipment.

7.4.4 Supply Connections

7.4.4.1

The power supply cord shall not have a grounding conductor.

7.4.4.2

The cord shall be separately insulated from exposed conductive parts at the point where it enters the equipment.

Note: A jacket on a cord is not considered supplementary insulation.

7.4.4.3

A metal strain relief clamp shall not be accessible and shall not make contact with an accessible non-current-carrying conductive part unless the clamp is suitably insulated from the cord.

7.4.5 Spacings

7.4.5.1

The spacings shall be not less than those specified in Table 7, except that larger spacings may be required at points at which

carbon dust, lubricants, or other conductive contaminants exist or may accumulate.

7.4.5.2

Magnet (eg, film-coated) wire shall be considered a bare live part in determining compliance with the spacings specified in Table 7.

7.4.5.3

When spacings are measured, all screws which are not prevented from loosening shall be positioned, by unscrewing if necessary, so as to produce minimum spacings.

7.4.5.4

All over-surface spacings shall be measured along or across the joints unless these joints are effectively cemented together.

7.4.5.5

Spacings measured through openings in housings of insulating material shall be measured from metal foil drawn tightly across the opening.

7.4.5.6

All air gaps shall be included in determining over-surface spacings except those less than 0.80 mm wide.

7.4.5.7

The depth of any groove less than 0.80 mm wide shall not be considered in determining the over-surface spacing.

7.5 Marking

Equipment conforming to these requirements shall be marked conspicuously and in a permanent manner with the statement DOUBLE INSULATED, or with the symbol specified in CSA Standard C22.2 No. 0.

7.6 Tests

7.6.1 Dielectric Strength

While at normal operating temperature, the complete heater shall be capable of withstanding, without breakdown, for a period of 1 min, the application of the ac test voltages specified in Table 8.

7.6.2 Leakage Current

7.6.2.1

When tested under the conditions specified in Clause 6.13, the leakage current shall not exceed

(a) 3.5 mA with the test voltage applied between each side of the supply circuit in turn, and inaccessible basic insulated non-current-carrying conductive parts; and

(b) 0.5 mA with the test voltage applied between each side of the supply circuit, in turn, and exposed non-current-carrying conductive parts or metal foil in contact with external nonmetallic surfaces.

7.6.2.2

Test voltage to be used to determine the leakage current shall be

110% of the nominal system voltage (as specified in CSA Standard C235), on which the equipment is intended to operate. (The test frequency shall be rated hertz.)

7.6.2.3

Prior to the measurement of the leakage current, the sample shall be operated under no-load conditions for 100 h or, where applicable, until the brushes wear out, whichever interval is shorter, where the brushes are not intended to be replaced without disassembly of the equipment.

Note: *The brushes may be replaced during this test.*

Following this no-load operation, and immediately prior to the measurement of the leakage current, the equipment shall be subjected for 48 h to a moist atmosphere having a relative humidity of 80 to 90% at a temperature of $25 \pm 2^\circ\text{C}$.

7.6.3 Abnormal Operation

7.6.3.1

Abnormal operation as specified in Clause 6.6 shall not cause failure of the insulation which will result in a shock hazard, as determined by the dielectric strength test in Clause 7.6.3.2.

7.6.3.2

Following the abnormal test specified in Clause 7.6.3.1, the heater shall be capable of withstanding, without breakdown, for a period of 1 min, the application of 1000 V ac between live parts and accessible non-current-carrying conductive parts (or metal foil in contact with external nonmetallic surfaces).

Table 1
Minimum Thickness for Cast Metal Enclosures
(See Clause 4.2.4.)

Method of fabrication	Minimum thickness, mm	
	Flat, unreinforced surfaces	Reinforced surfaces*
Die cast	2.0 mm	1.2 mm
Malleable iron	2.4 mm	1.6 mm
Other	3.2 mm	2.4 mm

**These thicknesses apply to surfaces which are curved, ribbed or otherwise reinforced, or if the size or shape or both are such that adequate mechanical strength is provided.*

Table 2
Acceptable Perforated Metal Panels
 (See Clause 4.2.6.8.5(b).)

Thickness, mm	Diameter of holes, mm	Spacing of holes centre to centre, mm
0.030	1.1	36 holes per sq. cm
0.030	1.27	2.47
0.035	1.97	3.27 (11 holes per sq. cm)
0.039	1.67	2.87

<http://www.china-gauges.com/>

Table 3
Openings in Guards or Enclosures for Moving Parts
 (See Clause 4.2.9.1.)

Minor dimensions of opening, mm*	Minimum distance from opening to moving part, mm*
6.47	12.7
9.5	38
12.7	63.5
19	114
25.4	165

*Openings less than 6.4 mm shall not be considered.

Table 4
 Minimum Spacings for Bare Live Parts
 (See Clauses 4.13 and 4.18.2.)

Spacing involved	Spacings, mm			
	0-300 v		301-600 v	
	Through air	Over surface	Through air	Over surface
A. At wiring terminals to which supply connections are made in the field:*				
(1) Between live parts of opposite polarity; and between live parts and non-current-carrying conductive parts other than the enclosure	6.4	9.5	9.5	12.7
(2) Between live parts and a conductive enclosure	12.7	12.7	12.7	12.7
B. At points other than included in A and C:				
(1) Between live parts of opposite polarity; and between live parts and non-current-carrying conductive parts other than the enclosure	1.6†	1.6	6.4	6.4
(2) Between live parts and a conductive enclosure	6.4	12.7	12.7	12.7
(3) Between open coil heating elements and the heater enclosure under any test condition	6.4	-	12.7	-
C. At closed-in points (protected against deposition of dirt) such as at element terminations of metal-sheathed elements and at screw-and-washer construction of an insulated terminal mounted in metal: between live parts and non-current-carrying conductive parts	1.2	1.2	2.4	2.4

*These spacings do not apply to connecting straps or buses extending away from wiring terminals; such spacings are judged under the requirements of Part B of Table 4.

†At open coil heating element insulators the spacings through air and over the surface from the heating element to non-current-carrying conductive parts shall not be less than 3.2 mm.

Table 5
Maximum Temperatures
(See Clause 6.4.1 and Table 6.)

Item	Location	Maximum temperature, °C
1*	At any point on or within a supply terminal box or a wiring compartment of a permanently connected heater.	60
2	Fibre used as electrical insulation or as a part whose failure would result in a hazardous condition	
3†	At any point on a heater cord if the retention of the insulation depends upon a fabric braid	
4‡	Flexible Cords	90
5	Wood and other combustible material	
6	Supporting surface upon which a stationary heater or a wall hung cord-connected heater may rest, or any adjacent surface, or the exterior surface of a heater intended for installation with no (zero) clearance to the test surface	
7	Heater surface at the points of contact of a heater with thermal insulation, test enclosure or supporting surface	90
8	At fuses	
9	Motor windings, cores, and other motor parts	See CSA Standard C22.2 No. 100.
10	On switch parts	See CSA Standards C22.2 No. 55 and C22.2 No. 111.
11§	On phenolic composition used as electrical insulation or as a part whose failure would result in a hazardous condition	150
12	On a supporting surface of pine upon which a portable heater may be placed, or on any adjacent surface	125
13	On nonmetallic enclosures	The limiting temperature of material.
14	On conductor insulation	The limiting temperature for the insulation.

*Higher temperatures shall be permitted if heaters are marked in accordance with Clause 5.1.6. This does not apply to ceiling mounted heaters specified in Clause 4.6.1.5.

†If the braid or jacket is removed and suitable supplementary means such as silicate of soda ($\text{Na}_2\text{Si}_4\text{O}_9$) are used to keep the insulation in place, the temperature may be as high as 150°C, and short lengths of the individual conductors may be exposed to temperatures in excess of 150°C, provided that they are not likely to be in contact with other conductors, non-current-carrying metal parts, or bare parts of opposite polarity.

‡Between the point of strain relief and the termination of the cord, the temperature on the cord may exceed 90°C as follows:

(a) The temperature may be as high as 150°C for thermoset cords (see Clause 4.6.2.3) and 121°C for thermoplastic cords (see Clause 4.6.2.4) if the conductors are separated and their insulation is adequately retained by a tight-fitting sleeve or wrap of a material suitable for the temperature.

(b) The temperature may be as high as 150°C for thermoset cords (see Clause 4.6.2.3) and 121°C for thermoplastic cords (see Clause 4.6.2.4) if the conductors are separated and cannot touch bare live parts or non-current carrying metal parts. The strain relief shall prevent motion of the cord in any direction.

(c) The temperature may exceed 150°C for thermoset cords (see Clause 4.6.2.3) and 121°C for thermoplastic cords (see Clause 4.6.2.4) under the conditions of Item (b) subject to investigation.

§This limitation does not apply to a composition which has been investigated and recognized as suitable for higher temperatures.

Table 6
Number of Cycles of Operation for Thermostat Endurance Test
 (See Clause 6.14.4.1.)

Type of thermostat	Automatic reset thermostat number of cycles
Temperature-regulating	A number of cycles equivalent to 1000 h of normal operation of the heater, but not less than 6000 cycles. However, the test may be omitted if, with the thermostat short-circuiting, no temperatures higher than the limits given in Table 4 are attained in the normal-temperature test.
Temperature-limiting	A number of cycles equivalent to 100 h of operation of the heater under any condition which causes the thermostat to function. However, the test may be omitted if with the thermostat short-circuited, there is no evidence of hazard as described in Clause 6.6.2 during continuous abnormal operation of the heater.
Combination temperature-limiting and -regulating	100 000 cycles with the thermostat short-circuited, there is evidence of hazard as described in Clause 6.6.2. If there is no evidence of hazard under this condition, the thermostat is to be tested as described above, for a temperature-regulating thermostat.

Note: The overload test (see Clause 6.14.3) is considered to provide an adequate test for thermostats of the manual reset type.

Table 7
Minimum Spacings for Double-Insulated Heaters
 (See Clauses 7.4.5.1 and 7.4.5.2.)

Item	Parts involved	Minimum spacing
1	Between bare live parts and inaccessible non-current-carrying conductive parts separated by basic insulation only	Not less than the through-air and over-surface spacings required by Clause 4.17 for bare live parts and exposed non-current-carrying metal parts
2	Between inaccessible non-current-carrying conductive parts and exposed non-current-carrying conductive parts separated by supplementary insulation	
3	Between bare live parts and exposed non-current-carrying conductive parts separated by double insulation or by reinforced insulation (where applicable), except as indicated in Item 4	Not less than twice the through-air and over-surface spacings required by Clause 4.17 for bare live parts and exposed non-current-carrying conductive parts
4	Between bare live parts and accessible non-current-carrying conductive parts at a commutator or other location in which foreign materials can build up	Over the surface 7.9 mm

Table 8
 Minimum Dielectric Strength Test Voltages
 (See Clause 7.6.1.)

Item	Point of application of test voltage	Minimum ac dielectric strength test voltage, volts-rms
1	Between live parts and inaccessible basic insulated non-current-carrying conductive parts	The value specified in Clause 6.5
2	Between inaccessible basic insulated non-current-carrying parts and accessible conductive parts	2500
3	Between inaccessible basic insulated non-current-carrying conductive parts and metal foil in contact with external nonmetallic surfaces (see Note 1)	2500
4	Between live parts with reinforced insulation and accessible non-current-carrying conductive parts	4000
5	Between live parts with reinforced insulation and metal foil in contact with external non-metallic surfaces (see Note 1)	4000
6	Between accessible non-current-carrying conductive parts (or metal foil in contact with external nonmetallic surfaces) and metal foil wrapped around the supply cord at the point of entry in the housing (or a metal rod of the same diameter as the cord inserted in its place) (see Note 2)	2500

Notes:

- (1) A coating of conductive material may be used in place of metal foil.
- (2) If the power supply cord enters through an opening in an insulating case, the metal foil is to be adjusted so that the distance between it and the metal rod is approximately 12.7 mm over surface.
- (3) For heaters having both reinforced insulation and double insulation, care is to be taken to ensure that the voltage applied to the reinforced insulation does not stress the basic insulation or the supplementary insulation more than they are stressed by the voltages specified in Table 8.

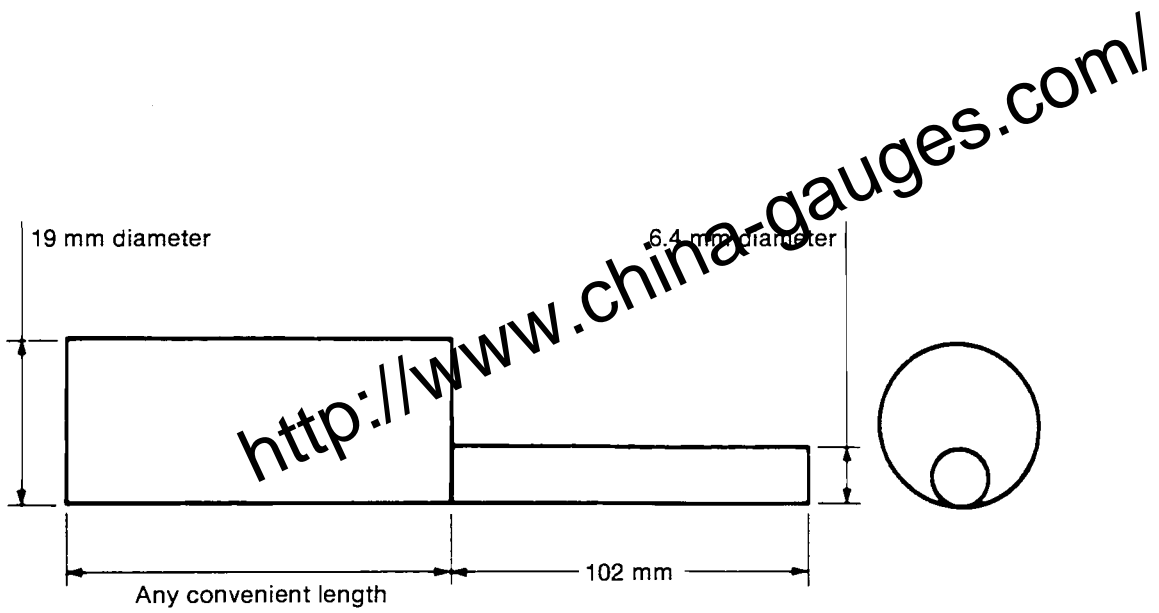

Figure 1
Probe
 (See Clause 4.2.6.1.)

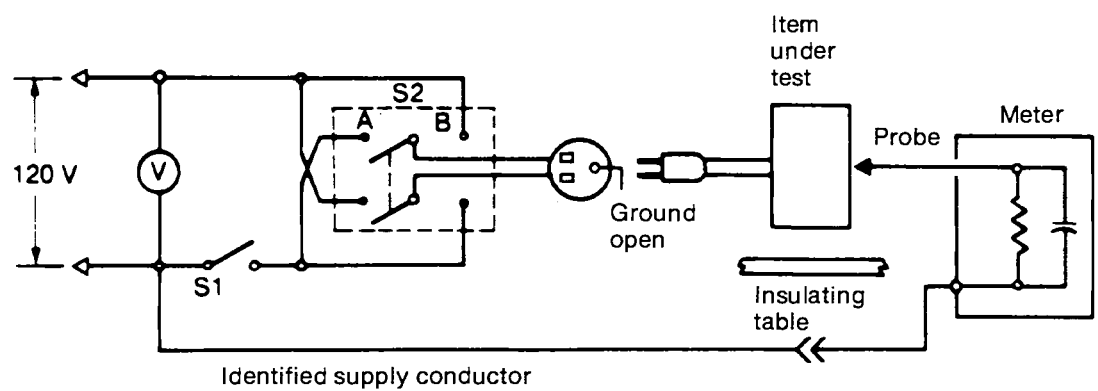

Figure 2
Leakage Current Measurement Circuit
 (See Clause 6.13.5.)

Proposal for Change

To help our volunteer members to assess proposals to change requirements we recommend that each proposal for change be submitted in writing and identify the

- (a) Standard number;
- (b) Clause number;
- (c) proposed wording of the Clause (requirement, test, or pass/fail criterion) using mandatory language and underlining those words changed from the existing Clause (if applicable); and
- (d) rationale for the change, including all supporting data necessary to be considered.

The proposal should be submitted to the Standards Administrator at least one month prior to the next meeting of the Committee. It is CSA Committee practice that only those proposals sent out to members prior to a meeting can be the subject of discussion and action. This is to allow the members time to consider the proposal and to do any research they may feel necessary.

Date: ____ - ____ - ____
YY MM DD

To: The Standards Administrator of CSA Standard _____

From: _____

Affiliation: _____

Address: _____

Phone: _____ **Fax:** _____

Re: Request for an Amendment, Deletion, or Addition to Clause(s) _____

Proposed change:



Product Description Produit	Quantity Nombre	Price Prix	Sub-Total Total	Shipping (see chart) Frais de port (voir grille)	Sub-Total Total	GST* TPS*	PST** TVP**	Sub-Total Total	QST*** TVQ***	Sub-Total Total
	X	=	=	+	=	+	=	=	=	=
	X	=	=	+	=	+	=	=	=	=
	X	=	=	+	=	+	=	=	=	=
	X	=	=	+	=	+	=	=	=	=
	X	=	=	+	=	+	=	=	=	=
Grand Total/Total global :										=

* Add GST to all Canadian Orders. (NOTE: The CE Code Handbook and all PLUS products are GST exempt.) / Ajouter la TPS à toute commande passée au Canada. (NOTE: Le Guide explicatif du CCE et les répertoires sont exempts de TPS.)
 ** Add PST on all orders for electronic products placed in Alberta, British Columbia, Manitoba, New Brunswick or Ontario. / Ajouter la TVP à toute commande de produits électroniques passés en Alberta, en Colombie-Britannique, au Manitoba, au Nouveau Brunswick et en Ontario.
 *** Add QST to all Québec orders. (NOTE: The CE Code Handbook and all PLUS products are QST exempt.) / Ajouter la TVQ à toute commande passée au Québec. (NOTE: Le Guide explicatif du CCE et les répertoires sont exempts de TVQ.)

SHIP TO • EXPÉDIER À If billing address is different, please specify.
 Si la facture doit être envoyée à une autre adresse, veuillez l'indiquer.

Name / Nom _____ Title / Titre _____
 Organization / Entreprise _____
 Address / Adresse _____
 City / Ville _____ Prov. / State / Prov. / État _____
 Country / Pays _____ Postal / Zip code / Code postal _____
 Telephone / Téléphone _____ SM or CM NO. / N° MS ou MC _____

Note. Discount applicable only if sustaining or certification No. provided.
 La remise est accordée uniquement si le n° de membre de soutien ou de certification est donné.

METHOD OF PAYMENT • MODALITÉS DE PAIEMENT

All first-time orders are to be paid by cash, cheque or credit card.
 Toute commande initiale doit être payée comptant, par chèque ou par carte de crédit.

1 Purchase Order No. • Bon d'achat n° _____ CSA Customer No. • N° de client CSA _____
 (North America only / Amérique du Nord seulement)

3 Payment enclosed \$ • Montant inclus \$ _____
 Make cheque payable to Canadian Standards Association. / Le chèque doit être fait à l'ordre de l'Association canadienne de normalisation.

Shipping and Handling • Frais de port et d'emballage

Product Produit	United States États-Unis	Canada	Other Countries Autres pays
Printed Publications Publications imprimées	\$10/copy 10 \$/exemplaire	\$4/copy 4 \$/exemplaire	\$10/copy 10 \$/exemplaire
CD-ROM 2200	\$60/year 60 \$/année	\$60/year 60 \$/année	\$200/year 200 \$/année
Other Electronic products Autres produits électroniques	\$15/copy 15 \$/exemplaire	\$15/copy 15 \$/exemplaire	\$60/copy 60 \$/exemplaire

NOTES
 (1) All printed publications are shipped by first class mail unless otherwise specified. All electronic products are shipped by courier.
 (2) Any items shipped to the United States, air or ground, may be charged custom charges for clearance. These charges are passed on to the consignee and are based on the declared value of the shipment.

REMARQUES
 (1) Sauf indication contraire, les publications imprimées sont envoyées par courriel de première classe, et les produits électroniques, par service de messagerie.
 (2) Tout article expédié aux États-Unis, par transport aérien ou terrestre, peut faire l'objet de frais de douanes. Ces frais, le cas échéant, sont payables par le destinataire et sont basés sur la valeur déclarée de l'envoi.

4 Charge to credit card indicated • Porter à mon compte :
 American Express Visa Master Card
 Expiration date / Date d'expiration _____
 Carte n° _____

Card holder's name • Nom du titulaire _____ Signature _____

Association Activities

The Canadian Standards Association is a not-for-profit, independent, private sector organization that serves the public, governments, and business as a forum for national consensus in the development of standards, and offers them certification, testing, and related services. It is a membership Association open to any individual, company, or organization interested in standards activities.

The more than 1000 standards published by CSA are written, reviewed, and revised by over 7000 committee members, who represent users, producers, and regulatory authorities in all regions of Canada. In addition to these volunteers, some 2000 representatives from industry, labour, governments, and the public participate in the work of the Association through sustaining memberships. Approximately one third of CSA's standards have been referenced into law by provincial and federal authorities.

Activities in the standards field cover a number of program areas: lifestyles and the environment, electrical/electronics, construction, energy, transportation/distribution, materials technology, business/production management systems, communications/information technology, and welding. These are all listed in our catalogue, which is available on request.

We welcome your comments and inquiries. Further information on standards programs may be obtained by writing to

*The Director, Standards Programs
Standards Development
Canadian Standards Association
178 Rexdale Boulevard
Rexdale (Toronto), Ontario
M9W 1R3*

<http://www.china-gauges.com/>



*A not-for-profit private sector organization
178 Rexdale Boulevard, Rexdale (Toronto), Ontario, Canada M9W 1R3
(416) 747-4000
Regional offices in Vancouver, Edmonton, Winnipeg, Montreal, Moncton*

Printed in Canada