



BSI Standards Publication

<http://www.china-gauges.com/>

Ships and marine technology — Offshore mooring chains

National foreword

This British Standard is the UK implementation of ISO 20438:2017.

The UK participation in its preparation was entrusted to Technical Committee SME/32, Ships and marine technology, Steering committee.

A list of organizations represented on this committee can be obtained on request to its secretary.

This publication does not purport to include all the necessary provisions of a contract. Users are responsible for its correct application.

© The British Standards Institution 2017

Published by BSI Standards Limited 2017

ISBN 978 0 580 89812 9

ICS 47.040

Compliance with a British Standard cannot confer immunity from legal obligations.

This British Standard was published under the authority of the Standards Policy and Strategy Committee on 31 July 2017.

Amendments/corrigenda issued since publication

Date	Text affected
------	---------------

INTERNATIONAL
STANDARD

ISO
20438

First edition
2017-06

<http://www.china-gauges.com/>

**Ships and marine technology —
Offshore mooring chains**

Navires et technologie maritime — Chaînes d'amarrage en haute mer



Reference number
ISO 20438:2017(E)

<http://www.china-gauges.com/>



COPYRIGHT PROTECTED DOCUMENT

© ISO 2017, Published in Switzerland

All rights reserved. Unless otherwise specified, no part of this publication may be reproduced or utilized otherwise in any form or by any means, electronic or mechanical, including photocopying, or posting on the internet or an intranet, without prior written permission. Permission can be requested from either ISO at the address below or ISO's member body in the country of the requester.

ISO copyright office
Ch. de Blandonnet 8 • CP 401
CH-1214 Vernier, Geneva, Switzerland
Tel. +41 22 749 01 11
Fax +41 22 749 09 47
copyright@iso.org
www.iso.org

Contents

	Page
Foreword.....	iv
1 Scope.....	1
2 Normative references.....	1
3 Terms and definitions.....	1
4 Grade.....	2
5 Materials.....	2
6 Shape, dimensions and tolerances.....	3
Bibliography.....	22

<http://www.china-gauges.com/>

Foreword

ISO (the International Organization for Standardization) is a worldwide federation of national standards bodies (ISO member bodies). The work of preparing International Standards is normally carried out through ISO technical committees. Each member body interested in a subject for which a technical committee has been established has the right to be represented on that committee. International organizations, governmental and non-governmental, in liaison with ISO, also take part in the work. ISO collaborates closely with the International Electrotechnical Commission (IEC) on all matters of electrotechnical standardization.

The procedures used to develop this document and those intended for its further maintenance are described in the ISO/IEC Directives, Part 1. In particular, the different approval criteria needed for the different types of ISO documents should be noted. This document was drafted in accordance with the editorial rules of the ISO/IEC Directives, Part 2 (see www.iso.org/directives).

Attention is drawn to the possibility that some of the elements of this document may be the subject of patent rights. ISO shall not be held responsible for identifying any or all such patent rights. Details of any patent rights identified during the development of the document will be in the Introduction and/or on the ISO list of patent declarations received (see www.iso.org/patents).

Any trade name used in this document is information given for the convenience of users and does not constitute an endorsement.

For an explanation on the voluntary nature of standards, the meaning of ISO specific terms and expressions related to conformity assessment, as well as information about ISO's adherence to the World Trade Organization (WTO) principles in the Technical Barriers to Trade (TBT) see the following URL: www.iso.org/iso/foreword.html.

This document was prepared by ISO/TC 8, *Ships and marine technology*, SC 4, *Outfitting and deck machinery*.

Ships and marine technology — Offshore mooring chains

1 Scope

This document specifies the requirements for grades, materials, shapes, proportions, dimensions and tolerances of offshore mooring chains.

2 Normative references

The following documents are referred to in the text in such a way that some or all of their content constitutes requirements of this document. For dated references, only the edition cited applies. For undated references, the latest edition of the referenced document (including any amendments) applies.

ISO 4967, *Steel — Determination of content of non-metallic inclusions — Micrographic method using standard diagrams*

ASTM A255, *Standard test methods for determining hardenability of steel*

ASTM E112, *Standard test methods for determining average grain size*

ASTM E381, *Standard method of macroetch testing steel bars, billets, blooms, and forgings*

3 Terms and definitions

For the purposes of this document, the terms and definitions given in ISO 19901-7:2013 and the following apply.

ISO and IEC maintain terminological databases for use in standardization at the following addresses:

- IEC Electropedia: available at <http://www.electropedia.org/>
- ISO Online browsing platform: available at <http://www.iso.org/obp>

3.1

mooring chain

component used for positioning and mooring of offshore structures composed of *chain links* (3.2) and *accessories* (3.3)

3.2

chain link

closed, link shaped components of *mooring chain* (3.1), including common stud link, common studless link, enlarged link and end link

3.3

accessory

detachable connectors used for joining different chain components, including *joining shackle*(3.8) and *end shackle*(3.9)

3.4

common stud link

common mooring *chain link* (3.2) with stud

3.5

common studless link

common mooring *chain link* (3.2) without stud

3.6

enlarged link

strengthened link that connects a common link and the *end link* (3.7)

3.7

end link

link that joins *mooring chains* (3.1) and shackles

3.8

joining shackle

accessories used for joining *chain links* (3.2) or other accessories, including "D" type LTM joining shackle, "D" type LTM end joining shackle, Kenter type joining shackle and "H" type LTM joining shackle

3.9

end shackle

accessories used for attaching the *mooring chain* (3.1) to mooring equipment

Note 1 to entry: It usually refers to LTM end shackle.

3.10

LTM shackle

long term moored "D" type joining shackle, "D" type end joining shackle and end shackle with the bolt fastened by nut

3.11

nominal diameter

diameter of the common link

4 Grade

4.1 The mooring chain is classified by tensile strength into five grades: R3, R3S, R4, R4S and R5.

4.2 The mechanical properties of mooring chain for each grade are given in [Table 1](#).

4.3 The proof load and breaking load of mooring chains for each grade are given in [Table 2](#).

5 Materials

5.1 The steel used for manufacturing of mooring chains is classified into five grades: R3, R3S, R4, R4S and R5.

5.2 Mechanical properties for materials of each grade shall meet the requirements of base materials specified in [Table 1](#).

5.3 The steel shall be manufactured by an electric progress or one of the basic oxygen processes or any other process involving secondary refining. The austenite grain size shall be 6 or finer in accordance with ASTM E112.

5.4 Steel grades R4S and R5 shall be vacuum degassed.

5.5 For steel grades R4S and R5, the following test results shall be supplied by steel mills to the mooring chain or accessory manufacturer:

a) Each heat shall be examined for non-metallic inclusions according to ISO 4967 or equivalent standards.

- b) A sample from each heat shall be macro etched according to ASTM E381 or equivalent standards to ensure there is no injurious segregation or porosity.
- c) Jominy hardenability data according to ASTM A255 or equivalent standards shall be supplied with each heat.

5.6 Steel grades R4, R4S and R5 shall contain a minimum of 0,20 % molybdenum.

6 Shape, dimensions and tolerances

6.1 The shapes of common studless link, common stud link, enlarged studless link, enlarged stud link and end link are indicated in [Figures 1 to 5](#) and their dimensions are specified in [Tables 3 to 7](#).

6.2 The shapes of kenter shackle, "H" type LTM joining shackle (sample), "D" type LTM end joining shackle (sample), "D" type LTM joining shackle, LTM end shackle are indicated in [Figures 6 to 10](#) and their dimensions are specified in [Tables 8 to 12](#).

6.3 Tolerances of common links, enlarged links and end links

The diameter shall be measured at crown, and the average value based on two perpendicular measurements must have no negative tolerance and the plus tolerance shall not exceed 5 % of nominal diameter. The minus tolerance for the diameter measured at crown shall meet the following requirements:

- for nominal diameter from 50 mm to 84 mm: -2 mm;
- for nominal diameter from 85 mm to 122 mm: -3 mm;
- for nominal diameter from 123 mm to 152 mm: -4 mm;
- for nominal diameter from 153 mm to 184 mm: -6 mm;
- for nominal diameter from 185 mm to 210 mm: -7,5 mm;
- for nominal diameter over 210 mm: -8,5 mm.

The cross sectional area of the crown shall not be less than the theoretical cross section of the nominal diameter.

The plus tolerance at weld shall not exceed 15 % of nominal chain diameter.

6.4 Length of five links

The five-link length of links shall be $5 \times p + 2 d = 22 d$ measured from outside. The allowable manufacturing tolerance on a length of five links is ${}^{+2,5}_0$ %.

6.5 All other dimensions

The tolerances of the diameter: ${}^{+5}_0$ %.

The tolerances other than diameter: $\pm 2,5$ %.

Table 1 — Mechanical properties of mooring chain

Grade	Minimum yield strength N/mm ²	Minimum tensile strength N/mm ²	Minimum elongation %	Minimum reduction in area %	Average impact energy J				
					Temperature °C	Base material		Weld	
						Average	Single value	Average	Single value
R3	410	690	17	50	0	60	45	38	
					-20	40	30	23	
R3S	490	770	15	50	0	55	49	53	
					-20	45	34	33	
R4	580	860	12	50	0	50	38	36	27
R4S	700	960	12	50	-20	56	42	40	30
R5	760	1000	12		-20	58	44	42	32

NOTE 1 Reduction of area of cast steel accessories is to be for Grades R3 and R3S: minimum 40 %; for Grades R4, R4S, and R5: minimum 35 %.

NOTE 2 CVN Impact Test of R3 and R3S may be performed either at 0 Deg. C or at -20 Deg. C.

NOTE 3 Aim maximum hardness for R4S is HB330 and R5 HB340.

NOTE 4 For guidance only: Typical yield to tensile strength ration is in the range of 0,85 to 0,95.

Table 2 — Proof load and breaking load

Dimensions in KN

	R3	R3S	R4	R4S	R5
Proof load of stud chain	0,0156d ² (44-0,08d)	0,0180d ² (44-0,08d)	0,0216d ² (44-0,08d)	0,0240d ² (44-0,08d)	0,0251d ² (44-0,08d)
Proof load of studless chain	0,0156d ² (44-0,08d)	0,0174d ² (44-0,08d)	0,0192d ² (44-0,08d)	0,0213d ² (44-0,08d)	0,0223d ² (44-0,08d)
Breaking load	0,0223d ² (44-0,08d)	0,0249d ² (44-0,08d)	0,0274d ² (44-0,08d)	0,0304d ² (44-0,08d)	0,0320d ² (44-0,08d)

NOTE d is the nominal diameter.

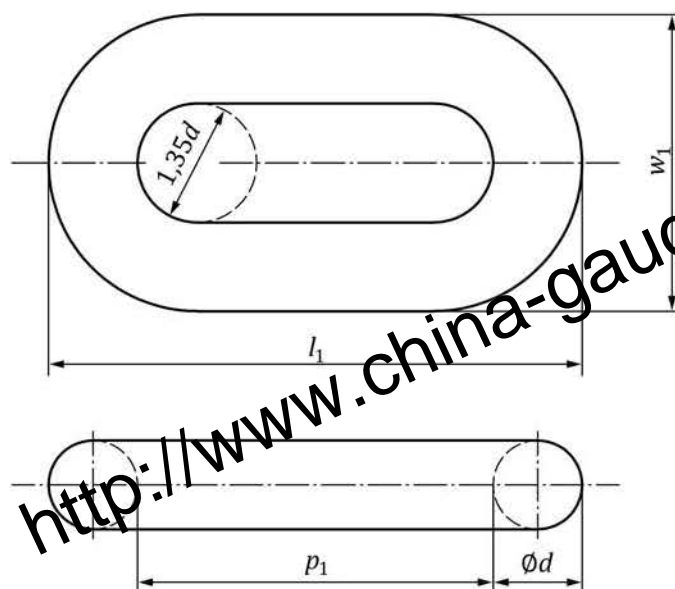

Key

d nominal diameter of common link

$l_1 = 6d$

$p_1 = 4d$

$w_1 = 3,35d$

NOTE For nominal dimensions, see [Table 3](#).

Figure 1 — Common studless link

Table 3 — Dimensions of common studless link

Dimensions in millimeters

Nominal size d	l_1	p_1	w_1	Nominal size d	l_1	p_1	w_1
50	300	200	168	120	720	480	402
52	312	208	174	122	732	488	409
54	324	216	181	124	744	496	415
56	336	224	188	127	762	508	425
58	348	232	194	130	780	520	436
60	360	240	201	132	792	528	442
62	372	248	208	137	822	548	459
64	384	256	214	142	852	568	476
66	396	264	221	147	882	588	492
68	408	272	228	152	912	608	509
70	420	280	235	157	942	628	526
73	438	292	245	162	972	648	543
76	456	304	255	165	990	660	553
78	468	312	261	168	1 008	672	563
81	486	324	271	171	1 026	684	573
84	504	336	281	175	1 050	700	586
87	522	348	291	178	1 068	712	596
90	540	360	302	180	1 080	720	603
92	552	368	308	182	1 092	728	610
95	570	380	318	185	1 110	740	620

Table 3 (continued)

Nominal size d	l_1	p_1	w_1	Nominal size d	l_1	p_1	w_1
97	582	388	325	188	1 128	752	630
100	600	400	335	191	1 156	764	640
102	612	408	342	194	1 164	776	650
105	630	420	352	197	1 182	788	660
107	642	428	358	200	1 200	800	670
111	666	444	372	205	1 230	820	687
114	684	456	382	210	1 260	840	704
117	702	468	392				

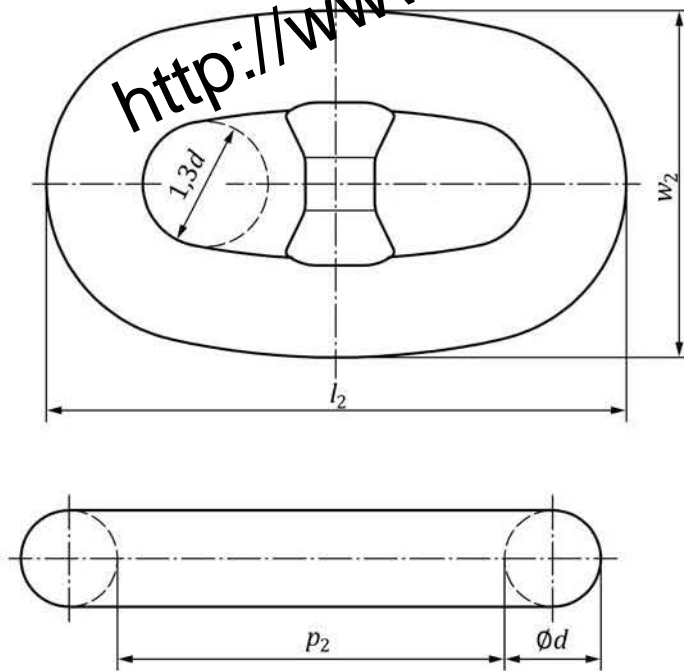

Key

d nominal diameter of common link

$l_2 = 6d$

$p_2 = 4d$

$w_2 = 3,6d$

NOTE For nominal dimensions, see [Table 4](#).

Figure 2 — Common stud link

Table 4 — Dimensions of common stud link

Dimensions in millimeters

Nominal size d	l_2	p_2	w_2	Nominal size d	l_2	p_2	w_2
50	300	200	180	120	720	480	432
52	312	208	187	122	732	488	439
54	324	216	194	124	744	496	446
56	336	224	202	127	762	508	457
58	348	232	209	130	780	520	468
60	360	240	216	132	792	528	475
62	372	248	223	137	822	548	493

Table 4 (continued)

Nominal size d	l_2	p_2	w_2	Nominal size d	l_2	p_2	w_2
64	384	256	230	142	852	568	511
66	396	264	238	147	882	588	529
68	408	272	245	152	912	608	547
70	420	280	252	157	942	628	565
73	438	292	263	162	972	648	583
76	456	304	274	165	990	660	594
78	468	312	281	168	1 008	672	605
81	486	324	292	171	1 026	684	616
84	504	336	302	175	1 050	700	630
87	522	348	313	178	1 068	712	641
90	540	360	324	180	1 080	720	648
92	552	368	331	182	1 092	728	655
95	570	380	342	185	1 110	740	666
97	582	388	349	188	1 128	752	677
100	600	400	360	191	1 146	764	688
102	612	408	367	194	1 164	776	698
105	630	420	378	197	1 182	788	709
107	642	428	385	200	1 200	800	720
111	666	444	400	205	1 230	820	738
114	684	456	410	210	1 260	840	756
117	702	468	421				

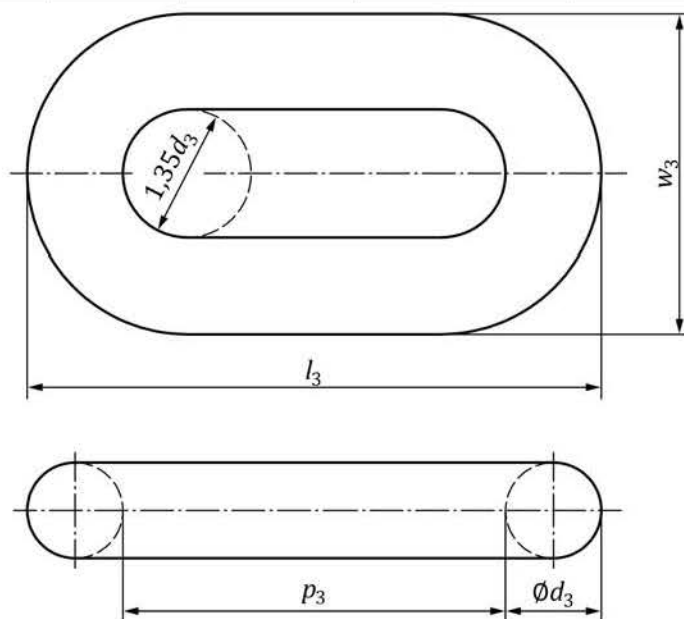

Key

- d nominal diameter of common link
- d_3 nominal diameter of enlarged studless link, $d_3 = 1,1d$
- $l_3 = 6d_3$
- $p_3 = 4d_3$
- $w_3 = 3,35d_3$

NOTE For nominal dimensions, see [Table 5](#).

Figure 3 — Enlarged studless link

Table 5 — Dimensions of enlarged studless link

Dimensions in millimeters

Nominal size (d , common link)	d_3	l_3	p_3	w_3	Nominal size (d , common link)	d_3	l_3	p_3	w_3
50	55	330	220	184	120	132	792	538	442
52	57	342	228	191	122	134	800	536	449
54	59	354	236	198	124	136	808	544	456
56	62	372	248	208	127	140	840	560	469
58	64	384	256	214	130	143	858	572	479
60	66	396	264	221	132	145	870	580	486
62	68	408	272	228	137	151	906	604	506
64	70	420	280	234	142	156	936	624	523
66	73	438	292	245	147	162	972	648	543
68	75	450	300	251	152	167	1 002	668	559
70	77	462	308	258	157	173	1 038	692	580
73	80	480	320	268	162	178	1 068	712	596
76	84	504	336	281	165	182	1 092	728	610
78	86	516	344	288	168	185	1 110	740	620
81	89	534	356	298	171	188	1 128	752	630
84	92	552	368	308	175	193	1 158	772	647
87	96	576	384	322	178	196	1 176	784	657
90	99	594	396	332	180	198	1 188	792	663
92	101	606	404	338	182	200	1 200	800	670
95	105	630	420	352	185	204	1 224	816	683
97	107	642	428	358	188	207	1 242	828	693
100	110	660	440	369	191	210	1 260	840	704
102	112	672	448	375	194	213	1 278	852	714
105	116	696	464	389	197	217	1 302	868	727
107	118	708	472	395	200	220	1 320	880	737
111	122	732	488	409	205	226	1 356	904	757
114	125	750	500	419	210	231	1 386	924	774
117	129	774	516	432					

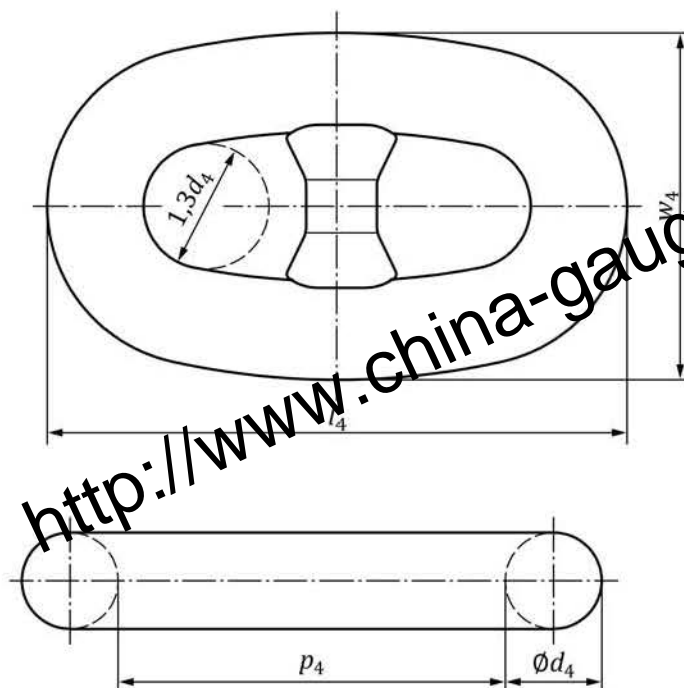

Key

- d nominal diameter of common stud link
- d_4 nominal diameter of enlarged stud link, $d_4 = 1,1d$
- $l_4 = 6d_4$
- $p_4 = 4d_4$
- $w_4 = 3,6d_4$

NOTE For nominal dimensions, see [Table 6](#).

Figure 4 — Enlarged stud link

Table 6 — Dimensions of enlarged stud link

Dimensions in millimeters

Nominal size (d , common link)	d_4	l_4	p_4	w_4	Nominal size (d , common link)	d_4	l_4	p_4	w_4
50	55	330	220	198	120	132	792	528	475
52	57	342	228	205	122	134	804	536	482
54	59	354	236	212	124	136	816	544	490
56	62	372	248	223	127	140	840	560	504
58	64	384	256	230	130	143	858	572	515
60	66	396	264	238	132	145	870	580	522
62	68	408	272	245	137	151	906	604	544
64	70	420	280	252	142	156	936	624	562
66	73	438	292	263	147	162	972	648	583
68	75	450	300	270	152	167	1 002	668	601
70	77	462	308	277	157	173	1 038	692	623
73	80	480	320	288	162	178	1 068	712	641
76	84	504	336	302	165	182	1 092	728	655
78	86	516	344	310	168	185	1 110	740	666
81	89	534	356	320	171	188	1 128	752	677

Table 6 (continued)

Nominal size (d , common link)	d_4	l_4	p_4	w_4	Nominal size (d , common link)	d_4	l_4	p_4	w_4
84	92	552	368	331	175	193	1 158	772	644
87	96	576	384	346	178	196	1 176	784	706
90	99	594	396	356	180	198	1 188	792	713
92	101	606	404	364	182	200	1 200	800	720
95	105	630	420	378	185	205	1 224	816	734
97	107	642	428	385	188	207	1 242	828	745
100	110	660	440	396	191	210	1 260	840	756
102	112	672	448	403	194	213	1 278	852	767
105	116	696	464	414	197	217	1 302	868	781
107	118	708	472	425	200	220	1 320	880	792
111	122	732	488	439	205	226	1 356	904	814
114	125	750	500	450	210	231	1 386	924	832
117	129	774	516	464					

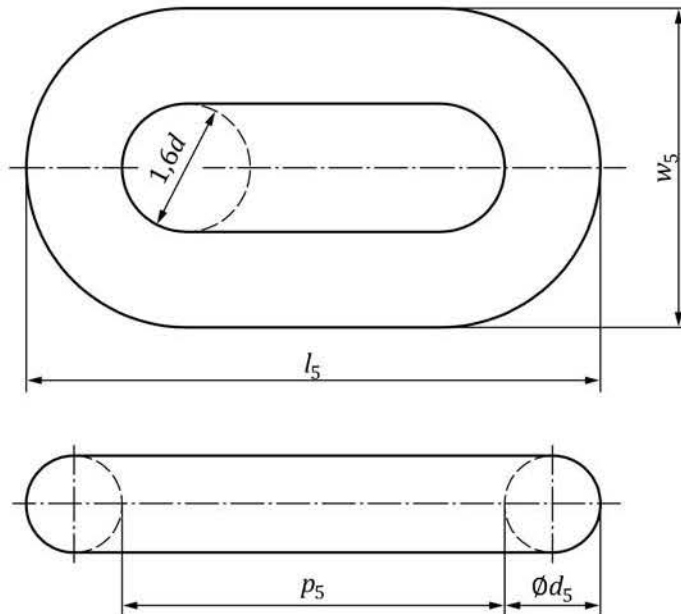

Key

- d nominal diameter of common link
- d_5 nominal diameter of enlarged stud link, $d_5 = 1,2d$
- $l_5 = 6,75d$
- $p_5 = 4,35d$
- $w_5 = 4d$

NOTE For nominal dimensions, see [Table 7](#).

Figure 5 — End link

Table 7 — Dimensions of end link

Dimensions in millimeters

Nominal size (<i>d</i> , common link)	<i>d</i> ₅	<i>l</i> ₅	<i>p</i> ₅	<i>w</i> ₅	Nominal size (<i>d</i> , common link)	<i>d</i> ₅	<i>l</i> ₅	<i>p</i> ₅	<i>w</i> ₅
50	60	338	218	200	120	144	810	522	480
52	62	351	226	208	122	146	824	531	488
54	65	365	235	216	124	149	837	539	496
56	67	378	244	224	127	152	857	552	508
58	70	392	252	232	130	156	878	566	520
60	72	405	261	240	132	158	891	574	528
62	74	419	270	248	137	164	925	596	548
64	77	432	278	256	142	170	959	618	568
66	79	446	287	264	147	176	992	639	588
68	82	459	296	272	152	182	1 026	661	608
70	84	473	305	280	157	188	1 060	683	628
73	88	493	318	292	162	194	1 094	705	648
76	91	513	331	304	165	198	1 114	718	660
78	94	527	339	312	168	202	1 134	731	672
81	97	547	352	324	171	205	1 154	744	684
84	101	567	365	336	175	210	1 181	761	700
87	104	587	378	348	178	214	1 202	774	712
90	108	608	392	360	180	216	1 215	783	720
92	110	621	400	368	182	218	1 229	792	728
95	114	641	413	380	185	222	1 249	805	740
97	116	655	422	388	188	226	1 269	818	752
100	120	675	435	400	191	229	1 289	831	764
102	122	689	444	408	194	233	1 310	844	776
105	126	709	457	420	197	236	1 330	857	788
107	128	722	465	428	200	240	1 350	870	800
111	133	749	483	444	205	246	1 384	892	820
114	137	770	496	456	210	252	1 418	914	840
117	140	790	509	468					

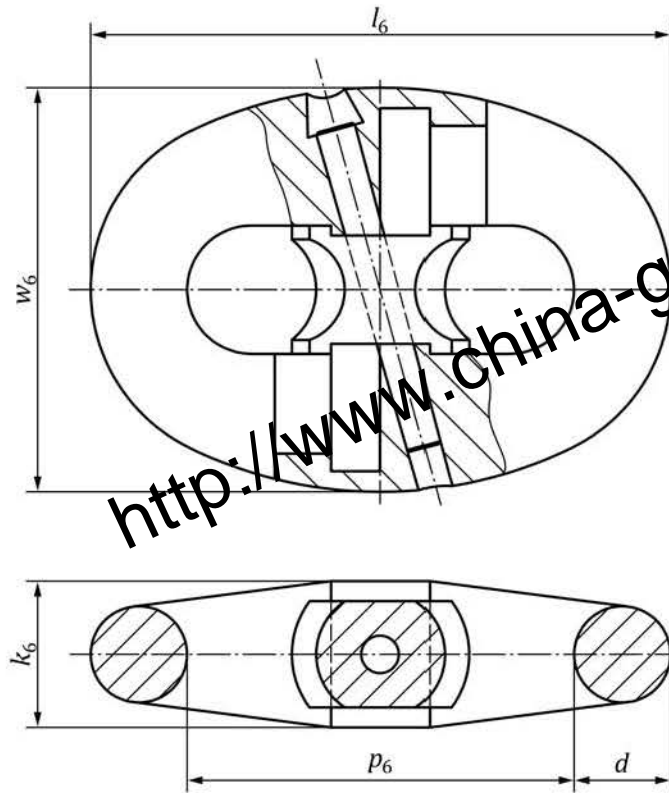

Key

d nominal diameter of common link

$k_6 = 1,52d$

$l_6 = 6d$

$p_6 = 4d$

$w_6 = 4,2d$

NOTE For nominal dimensions, see [Table 8](#).

Figure 6 — Kenter type joining shackle

Table 8 — Dimensions of Kenter type joining shackle

Dimensions in millimeters

Nominal size (d , common link)	l_6	p_6	w_6	k_6	Nominal size (d , common link)	l_6	p_6	w_6	k_6
50	300	200	210	76	120	720	480	504	182
52	312	208	218	79	122	732	488	512	185
54	324	216	227	82	124	744	496	521	188
56	336	224	235	85	127	762	508	533	193
58	348	232	244	88	130	780	520	546	198
60	360	240	252	91	132	792	528	554	201
62	372	248	260	94	137	822	548	575	208
64	384	256	269	97	142	852	568	596	216
66	396	264	277	100	147	882	588	617	223
68	408	272	286	103	152	912	608	638	231
70	420	280	294	106	157	942	628	659	239
73	438	292	307	111	162	972	648	680	246

Table 8 (continued)

Nominal size (<i>d</i> , common link)	<i>l</i> ₆	<i>p</i> ₆	<i>w</i> ₆	<i>k</i> ₆	Nominal size (<i>d</i> , common link)	<i>l</i> ₆	<i>p</i> ₆	<i>w</i> ₆	<i>k</i> ₆
76	456	304	319	116	165	990	660	698	251
78	468	312	328	119	168	1 008	672	706	255
81	486	324	340	123	171	1 026	684	718	260
84	504	336	353	128	175	1 050	700	735	266
87	522	348	365	132	178	1 068	712	748	271
90	540	360	378	137	180	1 080	720	756	274
92	552	368	386	140	182	1 092	728	764	277
95	570	380	399	144	185	1 110	740	777	281
97	582	388	407	147	188	1 128	752	790	286
100	600	400	420	152	191	1 146	764	802	290
102	612	408	428	155	194	1 164	776	815	295
105	630	420	441	160	197	1 182	788	827	299
107	642	428	449	163	200	1 200	800	840	304
111	666	444	466	169	205	1 230	820	861	312
114	684	456	479	173	210	1 260	840	882	319
117	702	468	491	178					

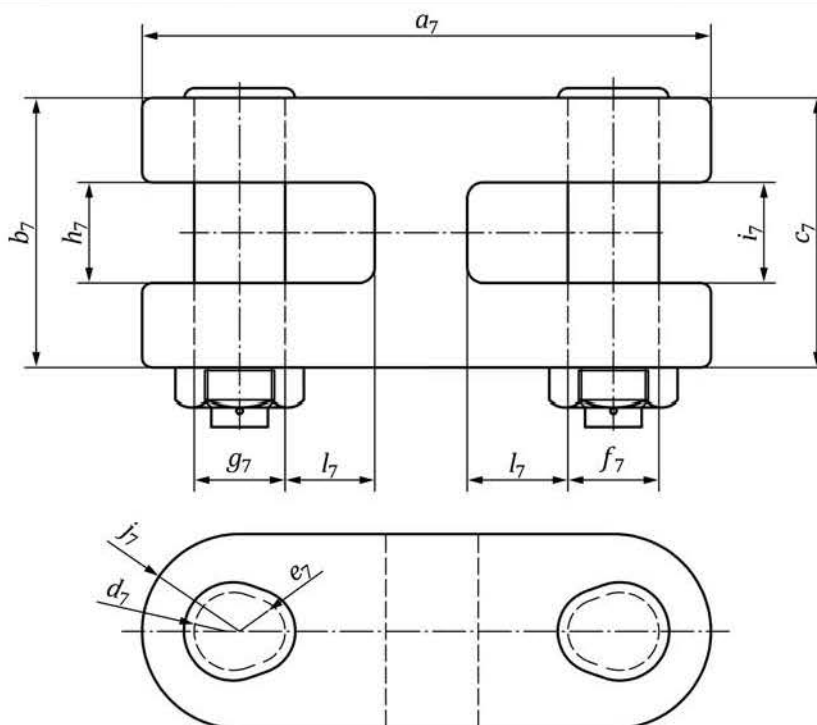

Key

d nominal diameter of common link

*a*₇ = 8,2*d*

*b*₇ = 3,75*d*

*c*₇ = 3,75*d*

*d*₇ = 0,6*d*

*e*₇ = 0,5*d*

*f*₇ = 1,4*d*

*g*₇ = 1,4*d*

*h*₇ = 1,15*d*

*i*₇ = 1,15*d*

*j*₇ = 1,5*d*

*l*₇ = 1,2*d*

NOTE For nominal dimensions, see [Table 9](#).

Figure 7 — “H” type LTM joining shackle (sample)

Table 9 — Dimensions of “H” type LTM joining shackle (sample)

Dimensions in millimeters

Nominal size (<i>d</i> , common link)	<i>a</i> ₇	<i>b</i> ₇	<i>c</i> ₇	<i>d</i> ₇	<i>e</i> ₇	<i>f</i> ₇	<i>g</i> ₇	<i>h</i> ₇	<i>i</i> ₇	<i>j</i> ₇	
50	410	188	188	30	25	70	70	58	58	75	60
52	426	195	195	31	26	73	73	60	60	78	62
54	443	203	203	32	27	76	76	62	62	81	65
56	459	210	210	34	28	78	78	64	64	84	67
58	476	218	218	35	29	81	81	67	67	87	70
60	492	225	225	36	30	84	84	69	69	90	72
62	508	233	233	37	31	87	87	71	71	93	74
64	525	240	240	38	32	90	90	74	74	96	77
66	541	248	248	40	33	92	92	76	76	99	79
68	558	255	255	41	34	95	95	78	78	102	82
70	574	263	263	42	35	98	98	81	81	105	84
73	599	274	274	44	37	102	102	84	84	110	88
76	623	285	285	46	38	106	106	87	87	114	91
78	640	293	293	47	39	109	109	90	90	117	94
81	664	304	304	49	41	113	113	93	93	122	97
84	689	315	315	50	42	118	118	97	97	126	101
87	713	326	326	52	44	122	122	100	100	131	104
90	738	338	338	54	45	126	126	104	104	135	108
92	754	345	345	55	46	129	129	106	106	138	110
95	779	356	356	57	48	133	133	109	109	143	114
97	795	364	364	58	49	136	136	112	112	146	116
100	820	375	375	60	50	140	140	115	115	150	120
102	836	383	383	61	51	143	143	117	117	153	122
105	861	394	394	63	53	147	147	121	121	158	126
107	877	401	401	64	54	150	150	123	123	161	128
111	910	416	416	67	56	155	155	128	128	167	133
114	935	428	428	68	57	160	160	131	131	171	137
117	959	439	439	70	59	164	164	135	135	176	140
120	984	450	450	72	60	168	168	138	138	180	144
122	1 000	458	458	73	61	171	171	140	140	183	146
124	1 017	465	465	74	62	174	174	143	143	186	149
127	1 041	476	476	76	64	178	178	146	146	191	152
130	1 066	488	488	78	65	182	182	150	150	195	156
132	1 082	495	495	79	66	185	185	152	152	198	158
137	1 123	514	514	82	69	192	192	158	158	206	164
142	1 164	533	533	85	71	199	199	163	163	213	170
147	1 205	551	551	88	74	206	206	169	169	221	176
152	1 246	570	570	91	76	213	213	175	175	228	182
157	1 287	589	589	94	79	220	220	181	181	236	188
162	1 328	608	608	97	81	227	227	186	186	243	194
165	1 353	619	619	99	83	231	231	190	190	248	198
168	1 378	630	630	101	84	235	235	193	193	252	202
171	1 402	641	641	103	86	239	239	197	197	257	205
175	1 435	656	656	105	88	245	245	201	201	263	210
178	1 460	668	668	107	89	249	249	205	205	267	214
180	1 476	675	675	108	90	252	252	207	207	270	216

Table 9 (continued)

Nominal size (<i>d</i> , common link)	<i>a</i> ₇	<i>b</i> ₇	<i>c</i> ₇	<i>d</i> ₇	<i>e</i> ₇	<i>f</i> ₇	<i>g</i> ₇	<i>h</i> ₇	<i>i</i> ₇	<i>j</i> ₇	<i>l</i> ₇
182	1 492	683	683	109	91	255	255	209	209	248	218
185	1 517	694	694	111	93	259	259	213	213	278	222
188	1 542	705	705	113	94	263	263	216	216	282	226
191	1 566	716	716	115	96	267	267	220	220	287	229
194	1 591	728	728	116	97	270	272	223	223	291	233
197	1 615	739	739	118	99	276	276	227	227	296	236
200	1 640	750	750	120	100	280	280	230	230	300	240
205	1 681	769	769	123	103	287	287	236	236	308	246
210	1 722	788	788	126	105	294	294	242	242	315	252

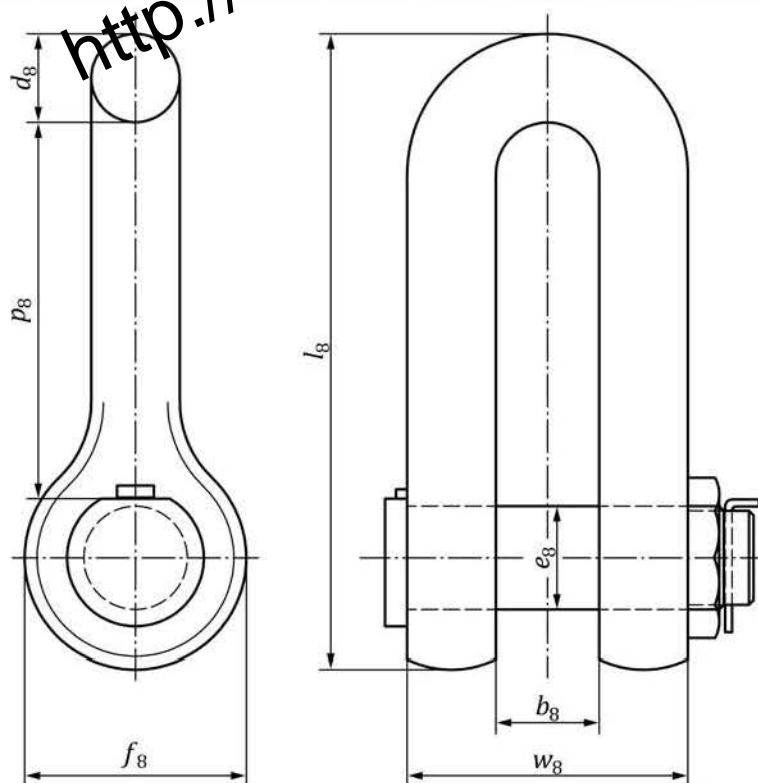

Key

d nominal diameter of common link

*b*₈ = 1,4*d*

*d*₈ = 1,2*d*

*e*₈ = 1,4*d*

*f*₈ = 3*d*

*l*₈ = 8,2*d*

*p*₈ = 5,2*d*

*w*₈ = 3,8*d*

NOTE For nominal dimensions, see [Table 10](#).

Figure 8 — “D” type LTM end joining shackle (sample)

Table 10 — Dimensions of “D” type LTM end joining shackle (sample)

Dimensions in millimeters

Nominal size (<i>d</i> , common link)	<i>d</i> ₈	<i>l</i> ₈	<i>b</i> ₈	<i>w</i> ₈	<i>e</i> ₈	<i>f</i> ₈	<i>h</i> ₈
50	60	430	70	190	70	150	260
52	62	447	73	198	73	156	270
54	65	464	76	205	76	162	281
56	67	482	78	213	78	168	291
58	70	499	81	220	81	174	302
60	72	516	84	228	84	180	312
62	74	533	87	236	87	186	322
64	77	550	90	243	90	192	333
66	79	568	92	251	92	198	343
68	82	585	95	258	95	204	354
70	84	602	98	266	98	210	364
73	88	628	102	277	102	219	380
76	91	654	106	289	106	228	395
78	94	671	109	296	109	234	406
81	97	697	113	308	113	243	421
84	101	722	118	319	118	252	437
87	104	748	122	331	122	261	452
90	108	774	126	342	126	270	468
92	110	791	129	350	129	276	478
95	114	817	133	361	133	285	494
97	116	834	136	369	136	291	504
100	120	860	140	380	140	300	520
102	122	877	143	388	143	306	530
105	126	903	147	399	147	315	546
107	128	920	150	407	150	321	556
111	133	955	155	422	155	333	577
114	137	980	160	433	160	342	593
117	140	1 006	164	445	164	351	608
120	144	1 032	168	456	168	360	624
122	146	1 049	171	464	171	366	634
124	149	1 066	174	471	174	372	645
127	152	1 092	178	483	178	381	660
130	156	1 118	182	494	182	390	676
132	158	1 135	185	502	185	396	686
137	164	1 178	192	521	192	411	712
142	170	1 221	199	540	199	426	738
147	176	1 264	206	559	206	441	764
152	182	1 307	213	578	213	456	790
157	188	1 350	220	597	220	471	816
162	194	1 393	227	616	227	486	842
165	198	1 419	231	627	231	495	858
168	202	1 445	235	638	235	504	874
171	205	1 471	239	650	239	513	889
175	210	1 505	245	665	245	525	910
178	214	1 531	249	676	249	534	926
180	216	1 548	252	684	252	540	936

Table 10 (continued)

Nominal size (<i>d</i> , common link)	<i>d</i> ₈	<i>l</i> ₈	<i>b</i> ₈	<i>w</i> ₈	<i>e</i> ₈	<i>f</i> ₈	<i>A</i> ₈
182	218	1 565	255	692	255	546	946
185	222	1 591	259	703	259	553	962
188	226	1 617	263	714	263	564	978
191	229	1 643	267	726	267	573	993
194	233	1 668	272	737	272	582	1 009
197	236	1 694	276	749	276	591	1 024
200	240	1 720	280	760	280	600	1 040
205	246	1 773	287	779	287	615	1 066
210	252	1 806	294	798	294	630	1 092

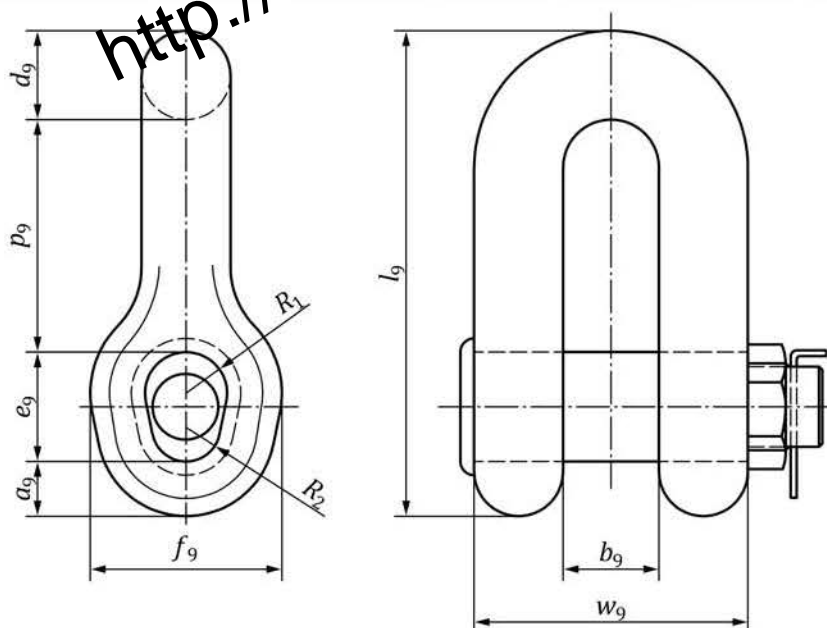

Key

d nominal diameter of common link

$$a_9 = 0,8d$$

$$b_9 = 1,4d$$

$$d_9 = 1,3d$$

$$e_9 = 1,6d$$

$$f_9 = 2,8d$$

$$l_9 = 7,1d$$

$$p_9 = 3,4d$$

$$w_9 = 4d$$

$$2R_1 = 1,2d$$

$$2R_2 = 1,0d$$

NOTE For nominal dimensions, see [Table 11](#).

Figure 9 — “D” type LTM joining shackle

Table 11 — Dimensions of “D” type LTM joining shackle

Dimensions in millimeters

Nominal size (d, common link)	d_9	l_9	w_9	a_9	b_9	e_9	f_9	$2R_1$	$2R_2$	r_9
50	65	355	200	40	70	80	140	60	50	170
52	68	369	208	42	73	83	146	62	52	177
54	70	383	216	43	76	86	151	65	54	184
56	73	398	224	45	78	90	157	67	56	190
58	75	412	232	46	81	93	162	70	58	197
60	78	426	240	48	84	96	168	72	60	204
62	81	440	248	49	87	99	174	74	62	211
64	83	454	256	51	90	102	179	77	64	218
66	86	469	264	53	92	106	185	79	66	224
68	88	483	272	54	95	109	190	82	68	231
70	91	497	280	56	98	112	196	84	70	238
73	95	518	292	58	102	117	204	88	73	248
76	99	540	304	61	106	122	213	91	76	258
78	101	554	312	62	109	125	218	94	78	265
81	105	575	324	65	113	130	227	97	81	275
84	109	596	336	67	118	134	235	101	84	286
87	113	618	348	70	122	139	244	104	87	296
90	117	639	360	72	126	144	252	108	90	306
92	120	653	368	74	129	147	258	110	92	313
95	124	675	380	76	133	152	266	114	95	323
97	126	689	388	78	136	155	272	116	97	330
100	130	710	400	80	140	160	280	120	100	340
102	133	724	408	82	143	163	286	122	102	347
105	137	746	420	84	147	168	294	126	105	357
107	139	760	428	86	150	171	300	128	107	364
111	144	788	444	89	155	178	311	133	111	377
114	148	809	456	91	160	182	319	137	114	388
117	152	831	468	94	164	187	328	140	117	398
120	156	852	480	96	168	192	336	144	120	408
122	159	866	488	98	171	195	342	146	122	415
124	161	880	496	99	174	198	347	149	124	422
127	165	902	508	102	178	203	356	152	127	432
130	169	923	520	104	182	208	364	156	130	442
132	172	937	528	106	185	211	370	158	132	449
137	178	973	548	110	192	219	384	164	137	466
142	185	1 008	568	114	199	227	398	170	142	483
147	191	1 044	588	118	206	235	412	176	147	500
152	198	1 079	608	122	213	243	426	182	152	517
157	204	1 115	628	126	220	251	440	188	157	534
162	211	1 150	648	130	227	259	454	194	162	551
165	215	1 172	660	132	231	264	462	198	165	561
168	218	1 193	672	134	235	269	470	202	168	571
171	222	1 214	684	137	239	274	479	205	171	581
175	228	1 243	700	140	245	280	490	210	175	595
178	231	1 264	712	142	249	285	498	214	178	605
180	234	1 278	720	144	252	288	504	216	180	612

<http://www.china-gauges.com/>

Table 11 (continued)

Nominal size (<i>d</i> , common link)	<i>d</i> ₉	<i>l</i> ₉	<i>w</i> ₉	<i>a</i> ₉	<i>b</i> ₉	<i>e</i> ₉	<i>f</i> ₉	2 <i>R</i> ₁	2 <i>R</i> ₂	<i>p</i> ₉
182	237	1 292	728	146	255	291	510	218	182	619
185	241	1 314	740	148	259	296	518	222	185	629
188	244	1 335	752	150	263	301	526	226	188	639
191	248	1 356	764	153	267	306	535	229	191	649
194	252	1 377	776	155	272	310	543	233	194	660
197	256	1 399	788	158	276	315	552	236	197	670
200	260	1 420	800	160	280	320	560	240	200	680
205	267	1 456	820	164	287	328	574	246	205	697
210	273	1 477	840	168	294	336	588	252	210	714

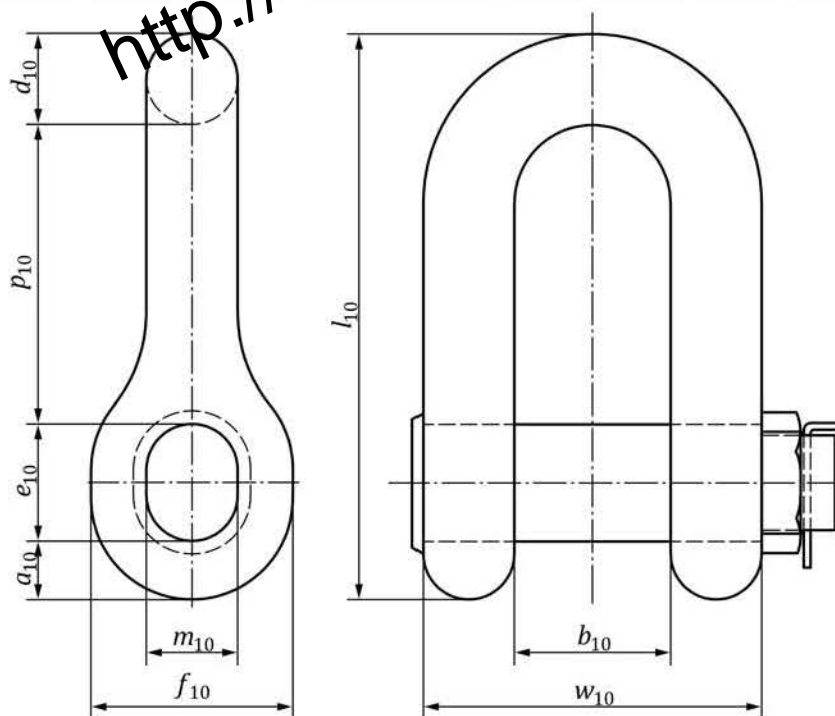

Key

d nominal diameter of common link

$$a_{10} = 0,9d$$

$$b_{10} = 2,4d$$

$$d_{10} = 1,4d$$

$$e_{10} = 1,8d$$

$$f_{10} = 3,1d$$

$$l_{10} = 8,7d$$

$$m_{10} = 1,4d$$

$$p_{10} = 4,6d$$

$$w_{10} = 5,2d$$

NOTE For nominal dimensions, see [Table 12](#).

Figure 10 — LTM end shackle

Table 12 — Dimensions of LTM end shackle

Dimensions in millimeters

Nominal size (<i>d</i> , common link)	<i>d</i> ₁₀	<i>l</i> ₁₀	<i>w</i> ₁₀	<i>b</i> ₁₀	<i>a</i> ₁₀	<i>e</i> ₁₀	<i>f</i> ₁₀	<i>m</i> ₁₀	<i>R</i> ₁₀
50	70	435	260	120	45	90	155	70	230
52	73	452	270	125	47	94	161	73	239
54	76	470	281	130	49	97	167	76	248
56	78	487	291	134	50	100	174	78	258
58	81	505	302	139	52	104	180	81	267
60	84	522	312	144	54	108	186	84	276
62	87	539	322	149	56	112	192	87	285
64	90	557	333	154	58	115	198	90	294
66	92	574	343	158	59	119	205	92	304
68	95	592	354	163	61	122	211	95	313
70	98	609	364	168	63	126	217	98	322
73	102	635	380	175	66	131	226	102	336
76	106	661	395	182	68	137	236	106	350
78	109	679	406	187	70	140	242	109	359
81	113	705	421	194	73	146	251	113	373
84	118	731	437	202	76	151	260	118	386
87	122	757	452	209	78	157	270	122	400
90	126	783	468	216	81	162	279	126	414
92	129	800	478	221	83	166	285	129	423
95	133	827	494	228	86	171	295	133	437
97	136	844	504	233	87	175	301	136	446
100	140	870	520	240	90	180	310	140	460
102	143	887	530	245	92	184	316	143	469
105	147	914	546	252	95	189	326	147	483
107	150	931	556	257	96	193	332	150	492
111	155	966	577	266	100	200	344	155	511
114	160	992	593	274	103	205	353	160	524
117	164	1 018	608	281	105	211	363	164	538
120	168	1 044	624	288	108	216	372	168	552
122	171	1 061	634	293	110	220	378	171	561
124	174	1 079	645	298	112	223	384	174	570
127	178	1 105	660	305	114	229	394	178	584
130	182	1 131	676	312	117	234	403	182	598
132	185	1 148	686	317	119	238	409	185	607
137	192	1 192	712	329	123	247	425	192	630
142	199	1 235	738	341	128	256	440	199	653
147	206	1 279	764	353	132	265	456	206	676
152	213	1 322	790	365	137	274	471	213	699
157	220	1 366	816	377	141	283	487	220	722
162	227	1 409	842	389	146	292	502	227	745
165	231	1 436	858	396	149	297	512	231	759
168	235	1 462	874	403	151	302	521	235	773
171	239	1 488	889	410	154	308	530	239	787
175	245	1 523	910	420	158	315	543	245	805
178	249	1 549	926	427	160	320	552	249	819
180	252	1 566	936	432	162	324	558	252	828

Table 12 (continued)

Nominal size (d, common link)	d_{10}	l_{10}	w_{10}	b_{10}	a_{10}	e_{10}	f_{10}	m_{10}	A_{10}
182	255	1 583	946	437	164	328	564	255	837
185	259	1 610	962	444	167	333	574	259	851
188	263	1 636	978	451	169	338	583	263	865
191	267	1 662	993	458	172	343	592	267	879
194	272	1 688	1 009	466	175	349	601	272	892
197	276	1 714	1 024	473	177	355	611	276	906
200	280	1 740	1 040	480	180	360	620	280	920
205	287	1 784	1 068	492	185	369	636	287	943
210	294	1 827	1 092	504	189	378	651	294	966

Bibliography

- [1] ISO 19901-7:2013, *Petroleum and natural gas industries — Specific requirements for offshore structures — Part 7: Stationkeeping systems for floating offshore structures and mobile offshore units*

<http://www.china-gauges.com/>

<http://www.china-gauges.com/>

<http://www.china-gauges.com/>

<http://www.china-gauges.com/>

British Standards Institution (BSI)

BSI is the national body responsible for preparing British Standards and other standards-related publications, information and services.

BSI is incorporated by Royal Charter. British Standards and other standardization products are published by BSI Standards Limited.

About us

We bring together business, industry, government, consumers, innovators and others to shape their combined experience and expertise into standards-based solutions.

The knowledge embodied in our standards has been carefully assembled in a dependable format and refined through our open consultation process. Organizations of all sizes and across all sectors choose standards to help them achieve their goals.

Information on standards

We can provide you with the knowledge that your organization needs to succeed. Find out more about British Standards by visiting our website at bsigroup.com/standards or contacting our Customer Services team or Knowledge Centre.

Buying standards

You can buy and download PDF versions of BSI publications, including British and adopted European and international standards, through our website at bsigroup.com/shop, where hard copies can also be purchased.

If you need international and foreign standards from other Standards Development Organizations, hard copies can be ordered from our Customer Services team.

Copyright in BSI publications

All the content in BSI publications, including British Standards, is the property of and copyrighted by BSI or some person or entity that owns copyright in the information used (such as the international standardization bodies) and has formally licensed such information to BSI for commercial publication and use.

Save for the provisions below, you may not transfer, share or disseminate any portion of the standard to any other person. You may not adapt, distribute, commercially exploit, or publicly display the standard or any portion thereof in any manner whatsoever without BSI's prior written consent.

Storing and using standards

Standards purchased in soft copy format:

- A British Standard purchased in soft copy format is licensed to a sole named user for personal or internal company use only.
- The standard may be stored on more than 1 device provided that it is accessible by the sole named user only and that only 1 copy is accessed at any one time.
- A single paper copy may be printed for personal or internal company use only.

Standards purchased in hard copy format:

- A British Standard purchased in hard copy format is for personal or internal company use only.
- It may not be further reproduced – in any format – to create an additional copy. This includes scanning of the document.

If you need more than 1 copy of the document, or if you wish to share the document on an internal network, you can save money by choosing a subscription product (see 'Subscriptions').

Reproducing extracts

For permission to reproduce content from BSI publications contact the BSI Copyright & Licensing team.

Subscriptions

Our range of subscription services are designed to make using standards easier for you. For further information on our subscription products go to bsigroup.com/subscriptions.

With **British Standards Online (BSOL)** you'll have instant access to over 55,000 British and adopted European and international standards from your desktop. It's available 24/7 and is refreshed daily so you'll always be up to date.

You can keep in touch with standards developments and receive substantial discounts on the purchase price of standards, both in single copy and subscription format, by becoming a **BSI Subscribing Member**.

PLUS is an updating service exclusive to BSI Subscribing Members. You will automatically receive the latest hard copy of your standards when they're revised or replaced.

To find out more about becoming a BSI Subscribing Member and the benefits of membership, please visit bsigroup.com/shop.

With a **Multi-User Network Licence (MUNL)** you are able to host standards publications on your intranet. Licences can cover as few or as many users as you wish. With updates supplied as soon as they're available, you can be sure your documentation is current. For further information, email subscriptions@bsigroup.com.

Revisions

Our British Standards and other publications are updated by amendment or revision.

We continually improve the quality of our products and services to benefit your business. If you find an inaccuracy or ambiguity within a British Standard or other BSI publication please inform the Knowledge Centre.

Useful Contacts

Customer Services

Tel: +44 345 086 9001

Email (orders): orders@bsigroup.com

Email (enquiries): cservices@bsigroup.com

Subscriptions

Tel: +44 345 086 9001

Email: subscriptions@bsigroup.com

Knowledge Centre

Tel: +44 20 8996 7004

Email: knowledgecentre@bsigroup.com

Copyright & Licensing

Tel: +44 20 8996 7070

Email: copyright@bsigroup.com

BSI Group Headquarters

389 Chiswick High Road London W4 4AL UK