



BSI Standards Publication

<http://www.china-gauges.com/>

Testing hardened concrete

Part 1: Shape, dimensions and other requirements for specimens and moulds

National foreword

This British Standard is the UK implementation of EN 12390-1:2021 and supersedes BS EN 12390-1:2012, which is withdrawn.

The UK participation in its preparation was entrusted to Technical Committee B/517/1, Concrete production and testing.

A list of organizations represented on this committee can be obtained on request to its committee manager.

Contractual and legal considerations

This publication has been prepared in good faith, however no representation, warranty, assurance or undertaking (express or implied) is or will be made, and no responsibility or liability is or will be accepted by BSI in relation to the adequacy, accuracy, completeness or reasonableness of this publication. All and any such responsibility and liability is expressly disclaimed to the full extent permitted by the law.

This publication is provided as is, and is to be used at the recipient's own risk.

The recipient is advised to consider seeking professional guidance with respect to its use of this publication.

This publication is not intended to constitute a contract. Users are responsible for its correct application.

© The British Standards Institution 2021
Published by BSI Standards Limited 2021

ISBN 978 0 539 05351 7

ICS 91.100.30

Compliance with a British Standard cannot confer immunity from legal obligations.

This British Standard was published under the authority of the Standards Policy and Strategy Committee on 31 July 2021.

Amendments/corrigenda issued since publication

Date	Text affected
------	---------------

EUROPEAN STANDARD

EN 12390-1

NORME EUROPÉENNE

EUROPÄISCHE NORM

July 2021

ICS 91.100.30

Supersedes EN 12390-1:2012

English Version

Testing hardened concrete - Part 1: Shape, dimensions
and other requirements for specimens and moulds

Essais pour béton durci - Partie 1 :
Forme, dimensions et autres exigences
aux éprouvettes et aux moules

Prüfung von Festbeton - Teil 1: Form, Maße und
andere Anforderungen für Probekörper und Formen

This European Standard was approved by CEN on 7 June 2021.

CEN members are bound to comply with the CEN/CENELEC Internal Regulations which stipulate the conditions for giving this European Standard the status of a national standard without any alteration. Up-to-date lists and bibliographical references concerning such national standards may be obtained on application to the CEN-CENELEC Management Centre or to any CEN member.

This European Standard exists in three official versions (English, French, German). A version in any other language made by translation under the responsibility of a CEN member into its own language and notified to the CEN-CENELEC Management Centre has the same status as the official versions.

CEN members are the national standards bodies of Austria, Belgium, Bulgaria, Croatia, Cyprus, Czech Republic, Denmark, Estonia, Finland, France, Germany, Greece, Hungary, Iceland, Ireland, Italy, Latvia, Lithuania, Luxembourg, Malta, Netherlands, Norway, Poland, Portugal, Republic of North Macedonia, Romania, Serbia, Slovakia, Slovenia, Spain, Sweden, Switzerland, Turkey and United Kingdom.



EUROPEAN COMMITTEE FOR STANDARDIZATION
COMITÉ EUROPÉEN DE NORMALISATION
EUROPÄISCHES KOMITEE FÜR NORMUNG

CEN-CENELEC Management Centre: Rue de la Science 23, B-1040 Brussels

Contents

Page

European foreword	iii
1 Scope	5
2 Normative references	5
3 Terms and definitions	5
4 Shape, dimensions and tolerances of specimens	5
4.1 General	5
4.2 Cubes	6
4.2.1 Nominal sizes	6
4.2.2 Designated sizes	6
4.2.3 Tolerances	6
4.3 Cylinders	6
4.3.1 Nominal sizes	6
4.3.2 Designated sizes	7
4.3.3 Tolerances	7
4.3.4 Applicability of tolerances	7
4.4 Prisms	7
4.4.1 Nominal sizes	7
4.4.2 Designated sizes	7
4.4.3 Tolerances	7
4.5 Measurement of dimensions and shape of specimens	8
5 Moulds	8
5.1 General	8
5.2 Calibrated moulds	8
5.2.1 General	8
5.2.2 Calibrated moulds for cubical specimens	9
5.2.3 Calibrated moulds for cylindrical specimens	9
5.2.4 Calibrated moulds for prismatic specimens	9
Annex A (normative) Application of EN ISO 1101 to concrete test specimens and moulds	10
Annex B (normative) Assessment of flatness of specimens and moulds	12

European foreword

This document (EN 12390-1:2021) has been prepared by Technical Committee CEN/TC 104 "Concrete and related products", the secretariat of which is held by SN.

This European Standard shall be given the status of a national standard, either by publication of an identical text or by endorsement, at the latest by January 2022, and conflicting national standards shall be withdrawn at the latest by January 2022.

Attention is drawn to the possibility that some of the elements of this document may be the subject of patent rights. CEN shall not be held responsible for identifying any or all such patent rights.

This document supersedes [EN 12390-1:2012](#).

The following amendments have been made to the former edition:

- editorial revision;
- increases in the allowable tolerances for flatness of moulds and the dimensions of the specimens which reflect current industry practice.

This document is one of a series on testing concrete.

EN 12390, *Testing hardened concrete*, consists of the following parts:

- *Part 1: Shape, dimensions and other requirements for specimens and moulds;*
- *Part 2: Making and curing specimens for strength tests;*
- *Part 3: Compressive strength of test specimens;*
- *Part 4: Compressive strength – Specification for testing machines;*
- *Part 5: Flexural strength of test specimens;*
- *Part 6: Tensile splitting strength of test specimens;*
- *Part 7: Density of hardened concrete;*
- *Part 8: Depth of penetration of water under pressure;*
- *Part 10: Determination of the carbonation resistance of concrete at atmospheric levels of carbon dioxide;*
- *Part 11: Determination of the chloride resistance of concrete, unidirectional diffusion;*
- *Part 12: Determination of the potential carbonation resistance of concrete: Accelerated carbonation method;*
- *Part 13: Determination of secant modulus of elasticity in compression;*
- *Part 14: Semi-adiabatic method for the determination of heat released by concrete during its hardening process;*
- *Part 15: Adiabatic method for the determination of heat released by concrete during its hardening process;*
- *Part 16: Determination of shrinkage of concrete;*
- *Part 17: Determination of creep of concrete in compression;*
- *Part 18: Determination of the chloride migration coefficient (in preparation).*

This document recognizes alternative approaches towards obtaining test specimens of the correct sizes and shapes. The first is to use moulds whose lives are limited and to measure the specimens to ensure

conformity. The second is to cast specimens in calibrated metal moulds which meet tighter tolerances than for specimens. The use of calibrated moulds allows relaxation on the requirement for measuring the specimens.

[Annex A](#) gives the application of EN ISO 1101 to measuring the shapes of concrete test specimens and moulds.

[Annex B](#) gives a method to measure the flatness of specimens and moulds.

Any feedback and questions on this document should be directed to the users' national standards body. A complete listing of these bodies can be found on the CEN website.

According to the CEN-CENELEC Internal Regulations, the national standards organisations of the following countries are bound to implement this European Standard: Austria, Belgium, Bulgaria, Croatia, Cyprus, Czech Republic, Denmark, Estonia, Finland, France, Germany, Greece, Hungary, Iceland, Ireland, Italy, Latvia, Lithuania, Luxembourg, Malta, Netherlands, Norway, Poland, Portugal, Republic of North Macedonia, Romania, Slovakia, Slovenia, Spain, Sweden, Switzerland, Turkey and the United Kingdom.

1 Scope

This document specifies the shapes, dimensions and tolerances of cast concrete test specimens in the form of cubes, cylinders and prisms, and of the moulds required to produce them.

NOTE The tolerances specified in this document are based on the needs of strength testing, but they can be applicable to tests for other properties.

2 Normative references

The following documents are referred to in the text in such a way that some or all of their content constitutes requirements of this document. For dated references, only the edition cited applies. For undated references, the latest edition of the referenced document (including any amendments) applies.

EN ISO 1101, *Geometrical product specifications (GPS) - Geometrical tolerancing - Tolerances of form, orientation, location and run-out* (ISO 1101)

[EN 206](#), *Concrete - Specification, performance, production and conformity*

3 Terms and definitions

For the purposes of this document, the terms and definitions given in EN ISO 1101 and the following apply.

ISO and IEC maintain terminological databases for use in standardization at the following addresses:

- IEC Electropedia: available at <https://www.electropedia.org/>
- ISO Online browsing platform: available at <https://www.iso.org/obp>

3.1

nominal size

commonly used description of specimen size

3.2

designated size

specimen size in millimetres, selected and declared by the user of this standard from amongst the allowed range of nominal sizes

4 Shape, dimensions and tolerances of specimens

4.1 General

For application of EN ISO 1101 to the measurement of concrete test specimens and moulds in respect to flatness, perpendicularity and straightness, see [Annex A](#).

For each shape of test specimen, cube, cylinder and prism, the nominal size d ([Figures 1, 2 and 3](#)) should be chosen to be at least three and a half times the maximum aggregate size (D_{\max} according to [EN 206](#)) in the concrete.

4.2 Cubes

4.2.1 Nominal sizes

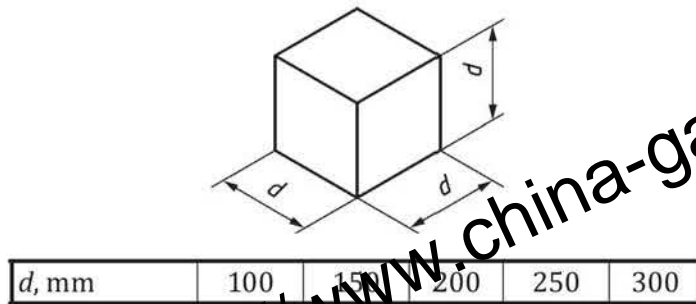

Figure 1 — Cube - nominal sizes

4.2.2 Designated sizes

Designated sizes may be selected within $\pm 10\%$ of the nominal size.

4.2.3 Tolerances

4.2.3.1 Between moulded surfaces the tolerance on the designated size (d) is 1,0 %.

4.2.3.2 Between the top trowelled face and the moulded bottom face the tolerance on the designated size is 1,5 %.

4.2.3.3 The tolerance on the flatness of the potential load bearing surfaces is $0,000\ 6d$ mm (see [Annex B](#)).

4.2.3.4 The tolerance on the perpendicularity of the sides of the cube, with reference to the base, as cast, is 0,5 mm.

4.3 Cylinders

4.3.1 Nominal sizes

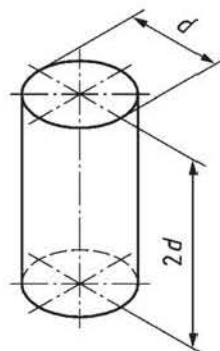

$d, \text{ mm}$	100	113 ^a	150	200	250	300
-----------------	-----	------------------	-----	-----	-----	-----

Figure 2 — Cylinder - nominal size

4.3.2 Designated sizes

Designated sizes may be selected within $\pm 10\%$ of the nominal size.

4.3.3 Tolerances

4.3.3.1 The tolerance on the designated diameter (d) is 1,0 %.

4.3.3.2 The tolerance on the flatness of the load-bearing surface is $0,0006d$ mm (see [Annex B](#)).

4.3.3.3 The tolerance on the perpendicularity of the side, with reference to the end faces, is $0,007d$ mm.

4.3.3.4 The tolerance on the height ($2d$) is 5 %.

4.3.3.5 For specimens to be used for the tensile splitting strength test, the straightness tolerance on the generating line of the cylinder is 0,2 mm.

4.3.4 Applicability of tolerances

4.3.4.1 Specimens with moulded end faces, or with end faces adjusted by grinding, shall conform to [4.3.3](#).

4.3.4.2 Specimens with end faces adjusted using sulfur capping, high alumina cement capping, or similar capping shall conform to [4.3.3.1](#) before capping and to [4.3.3.2](#), [4.3.3.3](#) and [4.3.3.4](#) after capping.

4.3.4.3 Specimens with end faces adjusted using the sandbox method or similar methods shall conform to [4.3.3.1](#) and [4.3.3.4](#) before capping and to [4.3.3.3](#) after fixing the box(es).

4.4 Prisms

4.4.1 Nominal sizes

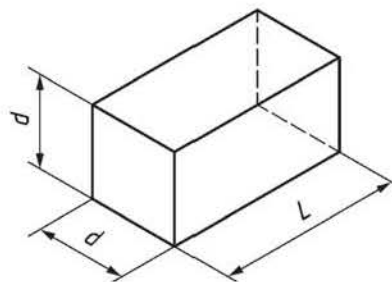

d , mm	70	100	150	200	250	300
----------	----	-----	-----	-----	-----	-----

Figure 3 — Prism - nominal sizes

4.4.2 Designated sizes

Designated sizes (d) may be selected within $\pm 10\%$ of the nominal sizes.

4.4.3 Tolerances

4.4.3.1 Between moulded surfaces, the tolerance on the designated size (d) is 1,0 %.

4.4.3.2 Between the top trowelled face and the bottom moulded face, the tolerance on the designated size is 1,5 %.

4.4.3.3 The tolerance on the perpendicularity of the sides of the prism with reference to the base as cast, is 0,5 mm.

4.4.3.4 The tolerances on the straightness of the line on the surface to be in contact with the rollers in the flexural strength test is 0,3 mm.

4.4.3.5 For specimens to be used for the tensile splitting strength test, the straightness tolerance on the load bearing surface is 0,3 mm.

4.5 Measurement of dimensions and shape of specimens

4.5.1 Unless specimens have documentation to show that they had been made in calibrated moulds, they shall be measured or checked for conformity to [4.2](#), [4.3](#) or [4.4](#) as appropriate.

NOTE Go/no-go gauges or other suitable method can be used to check dimensions.

4.5.2 If specimens have documentation to show that they have been made in calibrated moulds, only the requirements of [4.2.3.1](#) and [4.2.3.2](#) or [4.3.3.1](#), [4.3.3.2](#) and [4.3.3.4](#) or [4.4.3.1](#), [4.4.3.2](#), for cubes, cylinder or prisms, respectively, shall be checked.

NOTE 1 Go/no-go gauges or other suitable method can be used to check dimensions.

NOTE 2 If a surface, calibrated with respect to flatness, is used to form the load bearing surface of cylinders, [4.3.3.2](#) need not be performed.

NOTE 3 Guidance on the measurement of flatness of load-bearing surfaces is given in [Annex B](#).

5 Moulds

5.1 General

Moulds shall be watertight and non-absorbent.

NOTE The joints of moulds can be coated with wax, oil or grease to achieve water-tightness.

Moulds, other than calibrated moulds in accordance with [5.2](#), may be made from any material which is suitable for producing concrete specimens.

5.2 Calibrated moulds

5.2.1 General

Calibrated moulds shall be made of steel or cast iron, which shall be the reference materials. If moulds are manufactured from other materials, in-use performance test data shall be available which demonstrates long-term equivalence with steel or cast iron calibrated moulds.

All parts of calibrated moulds shall be sufficiently robust to prevent distortion on assembly and in use.

The components of the mould, with the possible exception of the base plate, shall have identification marks.

5.2.2 Calibrated moulds for cubical specimens

5.2.2.1 Moulds shall be suitable for producing specimens conforming to [4.2](#).

5.2.2.2 The tolerance on the designated size (d) of an assembled mould is 0,5 %.

5.2.2.3 The tolerance on the flatness of the four side faces of the mould is $0,000\ 6d$ mm.

5.2.2.4 The tolerance on the flatness of the top surface of the baseplate of the moulds is $0,001d$ mm.

5.2.2.5 The tolerance on the perpendicularity of the sides of a mould with respect to the adjacent sides and of the sides in relation to the base is 0,5 mm.

NOTE If necessary, the flatness tolerance can be measured with the mould disassembled (see [Annex B](#)).

5.2.3 Calibrated moulds for cylindrical specimens

5.2.3.1 Moulds shall be suitable for producing specimens conforming to [4.3](#).

5.2.3.2 The tolerance on the designated diameter (d) and the designated height ($2d$) is 0,5 %.

5.2.3.3 The tolerance on the flatness of a base of a mould is $0,000\ 6d$ mm.

5.2.3.4 The tolerance on the perpendicularity of the side of a mould with respect to the base is 0,5 mm.

NOTE If necessary, the flatness tolerance can be measured with the mould disassembled (see [Annex B](#)).

5.2.4 Calibrated moulds for prismatic specimens

5.2.4.1 Moulds shall be suitable for producing specimens conforming to [4.4](#).

5.2.4.2 The tolerance on the designated depth and width (d) of an assembled mould is 0,5 %.

5.2.4.3 The tolerance on the flatness of the internal sides is $0,002d$ mm.

5.2.4.4 The tolerance on the flatness of the top surface of the baseplate of the mould is $0,004d$ mm.

5.2.4.5 For mould surfaces with dimensions exceeding 150 mm, the flatness tolerances in [5.2.4.3](#) and [5.2.4.4](#) shall apply over any 150 mm length.

5.2.4.6 The tolerance on the perpendicularity of the sides of a mould with respect to the base is 0,5 mm.

NOTE If necessary, the flatness tolerance can be measured with the mould disassembled (see [Annex B](#)).

Annex A (normative)

Application of EN ISO 1101 to concrete test specimens and moulds

A.1 General

EN ISO 1101 describes the geometric tolerancing of drawings. Figures A.1, A.2 and A.3 show particular applications of the standard to the measurement of concrete test specimens and moulds.

A.2 Flatness

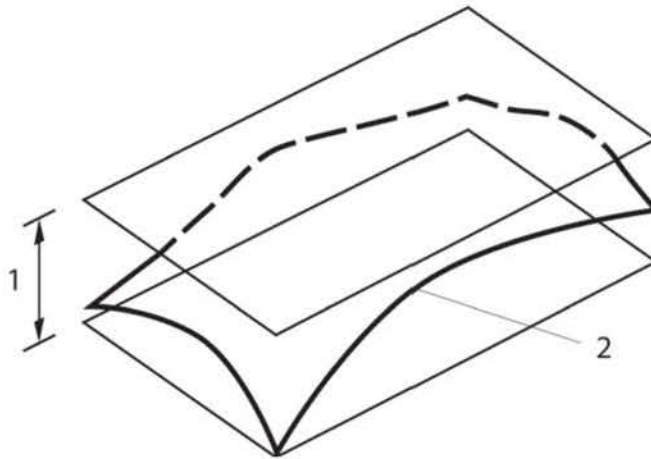

Key

- 1 flatness tolerance at any point across the face
- 2 surface to which flatness tolerance applies

Figure A.1 — Measurement of flatness

A.3 Perpendicularity

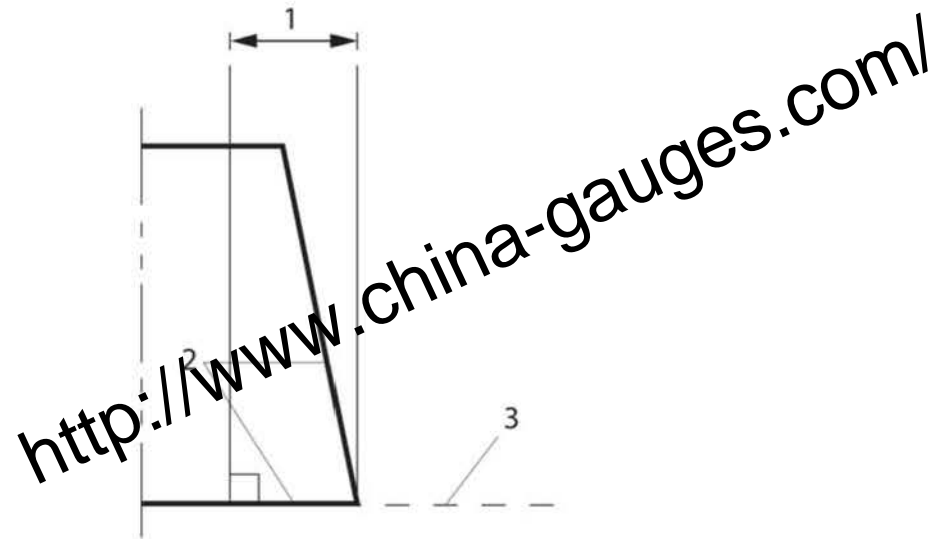

Key

- 1 perpendicularity tolerance
- 2 surfaces to which perpendicularity tolerance applies
- 3 adjacent surface as datum surface

Figure A.2 — Measurement of perpendicularity

A.4 Straightness

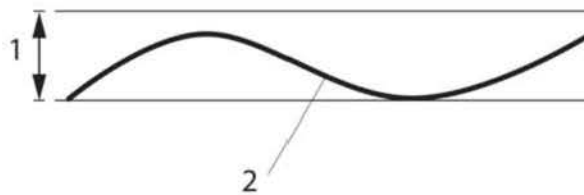

Key

- 1 straightness tolerance of the line on the load-bearing surface
- 2 line to which the straightness tolerance is applied

Figure A.3 — Measurement of straightness

Annex B (normative)

Assessment of flatness of specimens and moulds

For the purpose of this document, flatness shall be assessed by the measurement of straightness in four positions, as shown in [Figure B.1](#), for circular or rectilinear surfaces. Other methods giving at least the same degree of accuracy may be used.

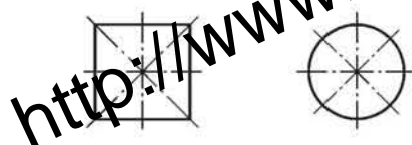

Figure B.1 — Measurement pattern for flatness of circular and rectilinear surfaces

The tolerance on straightness shall be equal to the tolerance on the flatness specified in [4.2](#), [4.3](#) or [4.4](#) as appropriate, for specimens, and in [5.2.2](#), [5.2.3](#) and [5.2.4](#), as appropriate, for moulds.

NOTE A steel straight-edge of rectangular section, and feeler gauges, with blades 0,03 mm to 1,00 mm thick, are considered suitable for this measurement, which characteristics could be defined on a national level.

<http://www.china-gauges.com/>

British Standards Institution (BSI)

BSI is the national body responsible for preparing British Standards and other standards-related publications, information and services.

BSI is incorporated by Royal Charter. British Standards and other standardization products are published by BSI Standards Limited.

About us

We bring together business, industry, government, consumers, innovators and others to shape their combined experience and expertise into standards-based solutions.

The knowledge embodied in our standards has been carefully assembled in a dependable format and refined through our open consultation process. Organizations of all sizes and across all sectors choose standards to help them achieve their goals.

Information on standards

We can provide you with the knowledge that your organization needs to succeed. Find out more about British Standards by visiting our website at bsigroup.com/standards or contacting our Customer Services team or Knowledge Centre.

Buying standards

You can buy and download PDF versions of BSI publications, including British and adopted European and international standards, through our website at bsigroup.com/shop, where hard copies can also be purchased.

If you need international and foreign standards from other Standards Development Organizations, hard copies can be ordered from our Customer Services team.

Copyright in BSI publications

All the content in BSI publications, including British Standards, is the property of and copyrighted by BSI or some person or entity that owns copyright in the information used (such as the international standardization bodies) and has formally licensed such information to BSI for commercial publication and use.

Save for the provisions below, you may not transfer, share or disseminate any portion of the standard to any other person. You may not adapt, distribute, commercially exploit or publicly display the standard or any portion thereof in any manner whatsoever without BSI's prior written consent.

Storing and using standards

Standards purchased in soft copy format:

- A British Standard purchased in soft copy format is licensed to a sole named user for personal or internal company use only.
- The standard may be stored on more than one device provided that it is accessible by the sole named user only and that only one copy is accessed at any one time.
- A single paper copy may be printed for personal or internal company use only.

Standards purchased in hard copy format:

- A British Standard purchased in hard copy format is for personal or internal company use only.
- It may not be further reproduced – in any format – to create an additional copy. This includes scanning of the document.

If you need more than one copy of the document, or if you wish to share the document on an internal network, you can save money by choosing a subscription product (see 'Subscriptions').

Reproducing extracts

For permission to reproduce content from BSI publications contact the BSI Copyright and Licensing team.

Subscriptions

Our range of subscription services are designed to make using standards easier for you. For further information on our subscription products go to bsigroup.com/subscriptions.

With **British Standards Online (BSOL)** you'll have instant access to over 55,000 British and adopted European and international standards from your desktop. It's available 24/7 and is refreshed daily so you'll always be up to date.

You can keep in touch with standards developments and receive substantial discounts on the purchase price of standards, both in single copy and subscription format, by becoming a **BSI Subscribing Member**.

PLUS is an updating service exclusive to BSI Subscribing Members. You will automatically receive the latest hard copy of your standards when they're revised or replaced.

To find out more about becoming a BSI Subscribing Member and the benefits of membership, please visit bsigroup.com/shop.

With a **Multi-User Network Licence (MUNL)** you are able to host standards publications on your intranet. Licences can cover as few or as many users as you wish. With updates supplied as soon as they're available, you can be sure your documentation is current. For further information, email cservices@bsigroup.com.

Revisions

Our British Standards and other publications are updated by amendment or revision.

We continually improve the quality of our products and services to benefit your business. If you find an inaccuracy or ambiguity within a British Standard or other BSI publication please inform the Knowledge Centre.

Useful Contacts

Customer Services

Tel: +44 345 086 9001

Email: cservices@bsigroup.com

Subscriptions

Tel: +44 345 086 9001

Email: subscriptions@bsigroup.com

Knowledge Centre

Tel: +44 20 8996 7004

Email: knowledgecentre@bsigroup.com

Copyright & Licensing

Tel: +44 20 8996 7070

Email: copyright@bsigroup.com

BSI Group Headquarters

389 Chiswick High Road London W4 4AL UK

<http://www.china-gauges.com/>