

# Marking of electrical and electronic equipment in accordance with Article 11(2) of Directive 2002/96/EC (WEEE)

<http://www.china-gauges.com/>

The European Standard EN 50419:2006 has the status of a  
British Standard

ICS 01.080.20; 29.020; 31.020

NO COPYING WITHOUT BSI PERMISSION EXCEPT AS PERMITTED BY COPYRIGHT LAW

## National foreword

This British Standard is the official English language version of EN 50419:2006. It supersedes BS EN 50419:2005 which is withdrawn.

The UK participation in its preparation was entrusted to Technical Committee L/7/1, Waste from electrical and electronic equipment, which has the responsibility to:

- aid enquirers to understand the text;
- present to the responsible international/European committee any enquiries on the interpretation, or proposals for change, and keep UK interests informed;
- monitor related international and European developments and promulgate them in the UK.

A list of organizations represented on this committee can be obtained on request to its secretary.

### Cross-references

The British Standards which implement international or European publications referred to in this document may be found in the *BSI Catalogue* under the section entitled “International Standards Correspondence Index”, or by using the “Search” facility of the *BSI Electronic Catalogue* or of British Standards Online.

This publication does not purport to include all the necessary provisions of a contract. Users are responsible for its correct application.

**Compliance with a British Standard does not of itself confer immunity from legal obligations.**

<http://www.china-gauges.com/>

### Summary of pages

This document comprises a front cover, an inside front cover, the EN title page, pages 2 to 8, an inside back cover and a back cover.

The BSI copyright notice displayed in this document indicates when the document was last issued.

This British Standard was published under the authority of the Standards Policy and Strategy Committee on 31 March 2006

© BSI 2006

ISBN 0 580 48114 X

### Amendments issued since publication

| Amd. No. | Date | Comments |
|----------|------|----------|
|          |      |          |
|          |      |          |
|          |      |          |
|          |      |          |
|          |      |          |

EUROPEAN STANDARD

**EN 50419**

NORME EUROPÉENNE

EUROPÄISCHE NORM

March 2006

ICS 01.080.20; 29.020; 31.020

Supersedes EN 50419:2005

English version

**Marking of electrical and electronic equipment in accordance  
with Article 11(2) of Directive 2002/96/EC (WEEE)**

Marquage des équipements  
électriques et électroniques  
conformément à l'Article 11(2)  
de la Directive 2002/96/CE (DEEE)

Kennzeichnung von Elektro-  
und Elektronikgeräten  
entsprechend Artikel 11(2)  
der Richtlinie 2002/96/EG (WEEE)

This European Standard was approved by CENELEC on 2006-03-01. CENELEC members are bound to comply with the CEN/CENELEC Internal Regulations which stipulate the conditions for giving this European Standard the status of a national standard without any alteration.

Up-to-date lists and bibliographical references concerning such national standards may be obtained on application to the Central Secretariat or to any CENELEC member.

This European Standard exists in three official versions (English, French, German). A version in any other language made by translation under the responsibility of a CENELEC member into its own language and notified to the Central Secretariat has the same status as the official versions.

CENELEC members are the national electrotechnical committees of Austria, Belgium, Cyprus, the Czech Republic, Denmark, Estonia, Finland, France, Germany, Greece, Hungary, Iceland, Ireland, Italy, Latvia, Lithuania, Luxembourg, Malta, the Netherlands, Norway, Poland, Portugal, Romania, Slovakia, Slovenia, Spain, Sweden, Switzerland and the United Kingdom.

**CENELEC**

European Committee for Electrotechnical Standardization  
Comité Européen de Normalisation Electrotechnique  
Europäisches Komitee für Elektrotechnische Normung

**Central Secretariat: rue de Stassart 35, B - 1050 Brussels**

© 2006 CENELEC - All rights of exploitation in any form and by any means reserved worldwide for CENELEC members.

Ref. No. EN 50419:2006 E

## Foreword

This European Standard was prepared by CENELEC BTTF 116-3, Waste from electrical and electronic equipment (WEEE).

The text of a draft amendment to EN 50419:2005 was submitted to the formal vote and was approved by CENELEC on 2006-03-01 to be combined and published as a new edition of EN 50419.

This European Standard supersedes EN 50419:2005 and its corrigendum February 2005.

The following dates were fixed:

- latest date by which the EN has to be implemented  
at national level by publication of an identical  
national standard or by endorsement (dop) 2006-06-01
- latest date by which the national standards conflicting  
with the EN have to be withdrawn (dow) 2006-06-01

This European Standard was prepared under the mandate M/336 given to CENELEC by the European Commission and the European Free Trade Association and supports the essential requirements of Directive 2002/96/EC.

<http://www.china-gauges.com/>

## Contents

|                                   | Page |
|-----------------------------------|------|
| 1 Scope.....                      | 4    |
| 2 Normative references .....      | 4    |
| 3 Definitions .....               | 4    |
| 4 Marking .....                   | 5    |
| 4.1 Requirements of marking.....  | 5    |
| 4.2 Design of the marking .....   | 5    |
| 4.3 Location of the marking ..... | 7    |
| Bibliography.....                 | 8    |

<http://www.china-gauges.com/>

## 1 Scope

This European Standard specifies a marking

- of electrical and electronic equipment in accordance with Article 11(2) of Directive 2002/96/EC (WEEE);

NOTE This is in addition to the marking requirement in Article 10(3) of this Directive which requires producers to mark electrical and electronic equipment put on the market after 13 August 2005 with a 'crossed-out wheeled bin' symbol.

- that applies to electrical and electronic equipment falling under Annex IA of Directive 2002/96/EC, provided the equipment concerned is not part of another type of equipment that does not fall within the scope of this Directive. Annex IB of Directive 2002/96/EC contains an indicative list of the products, which fall under the categories set out in Annex IA of this Directive;
- that serves to clearly identify the producer of the equipment and that the equipment has been put on the market after 13 August 2005.

The definition of a technical carrier medium for identifying the producer, such as a barcode, electronic data medium or microchip, is not covered by this standard.

## 2 Normative references

The following referenced documents are indispensable for the application of this document. For dated references, only the edition cited applies. For undated references, the latest edition of the referenced document (including any amendments) applies.

ISO 8601:2004, *Data elements and interchange formats - Information interchange - Representation of dates and times*

## 3 Definitions

For the purposes of this document, the following terms and definitions apply.

### 3.1 electrical and electronic equipment

equipment which is dependent on electric currents or electro-magnetic fields in order to work properly and equipment for the generation, transfer and measurement of such currents and fields falling under the categories set out in Annex IA of Directive 2002/96/EC and designed for use with a voltage rating not exceeding 1 000 V for alternating current and 1 500 V for direct current

### 3.2

#### producer

any person who, irrespective of the selling technique used, including by means of distance communication in accordance with Directive 97/7/EC:

- a) manufactures and sells electrical and electronic equipment under his own brand; or
- b) resells under his own brand equipment produced by other suppliers, a reseller not being regarded as the 'producer' if the brand of the producer appears on the equipment, as provided for in point a), or;
- c) imports or exports electrical or electronic equipment on a professional basis into a Member State

## 4 Marking

### 4.1 Requirements of marking

In order to identify a) the producer and b) the equipment put on the market after 13 August 2005, the following markings shall be applied on the product:

- a) a unique identification of the producer. This can take the form of a brand name, trademark, company registration number or other suitable means to identify the producer. Whichever option is chosen this shall be recorded in the Member State's register of producers in accordance with Article 12(1) of Directive 2002/96/EC (WEEE);
- b) put on the market after 13 August 2005 shall be identified by at least one of the following options:
  - 1) the date of manufacture/put on the market, in un-coded text in accordance with ISO 8601 or other coded text, for which the code shall be made available for treatment facilities.

When using the representation of date according to ISO 8601, it is permitted to omit higher order components (truncation), if there is no risk of confusing these truncated representations with others;

- 2) marking as shown in Figure 1 being an additional mark used in conjunction with the crossed-out wheeled bin in accordance with Annex IV of Directive 2002/96/EC already required under Article 10(3) of this Directive.

NOTE This does not exclude the use of both options at the same time.

The marking shall be visible, legible and indelible. For location, see 4.3.

### 4.2 Design of the marking

The additional marking referred to in 4.1 b) 2) shall consist of a solid bar, the height of which equals  $h$  and the width of which equals  $1/2 a$ . The height ( $h$ ) of the bar shall be the greater of  $0,3 a$  or  $1$  mm. The bar shall only be used in conjunction with the crossed-out wheeled bin. The bar shall not contain any text or any kind of additional information.

The symbol combination shown in Figure 1 shall have a minimum height of  $7$  mm ( $a = 3,33$  mm).

NOTE 1 The dimension of  $7$  mm provides a vertical dimension of  $5$  mm for the crossed-out wheeled bin symbol, which is the same minimum dimension as provided for in EN 61429/A11 and for the CE mark according to the Directive 93/68/EEC. This also equates to a maximum reading distance of  $50$  cm of the crossed-out wheeled bin symbol for the minimum symbol height of  $5$  mm as derived from EN 80416-3 Clause 5.

The dimensional relationship shown in Figure 1 shall be maintained.

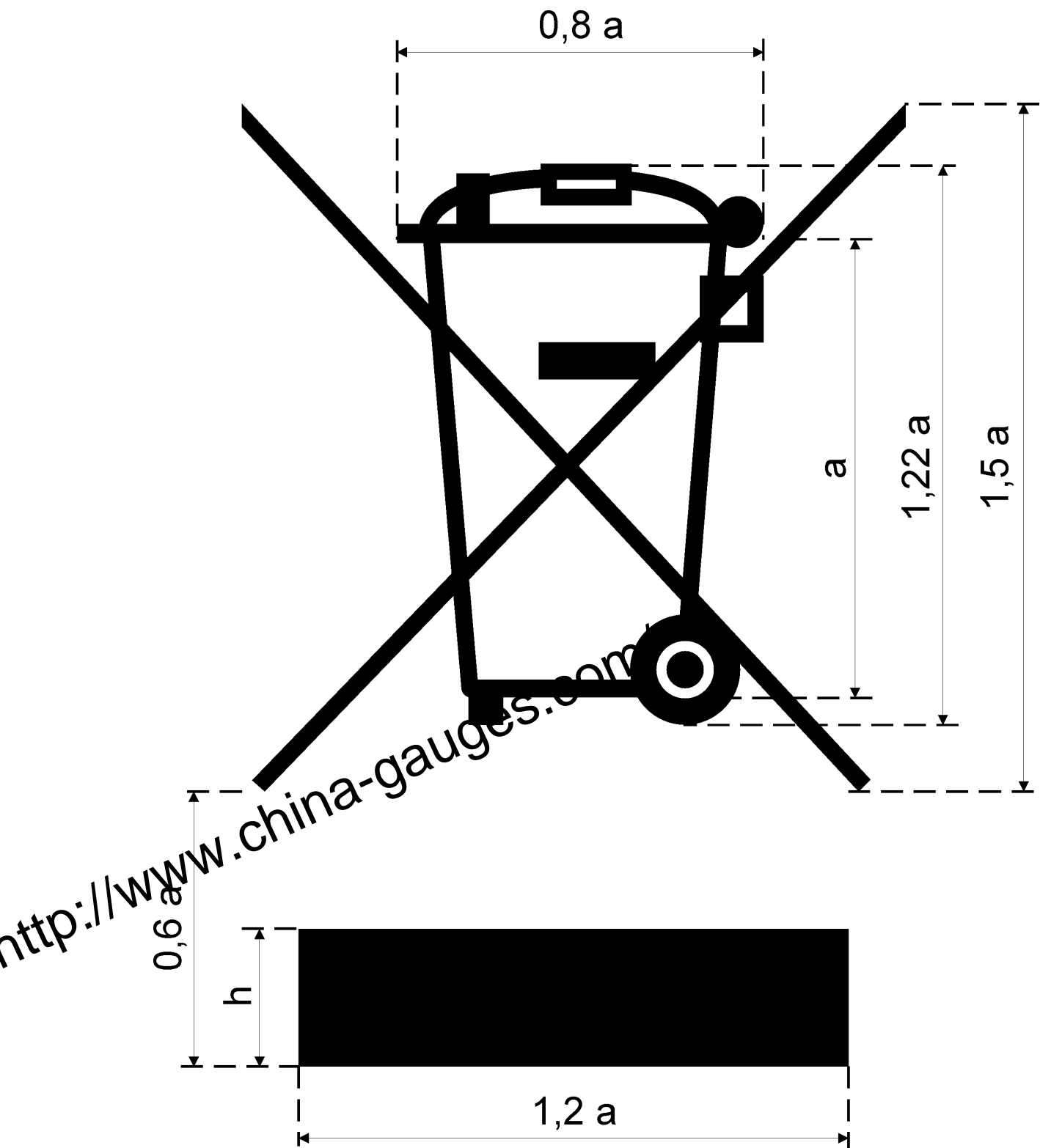

Figure 1 – Marking of electrical and electronic equipment as required by 4.1 b) 2)

NOTE 2 The symbol of the crossed out wheeled bin and the dimensional relationship are the same as required for batteries and defined in Figure 2 of EN 61429/A11.

When using the marking in Figure 1 modifications caused by production limitations and variations (e.g. modifying of line thickness, rounding of corners, matching of lines) are permitted provided the visual appearance is maintained.



In the absence of relevant product standards or if the relevant product standard does not include marking durability requirements, the following shall apply:

Compliance is checked by inspection and by rubbing by hand for 15 s with a piece of cloth soaked with water and again for 15 s with a piece of cloth soaked with petroleum spirit.

After this test, the marking shall be legible, it shall not be easily possible to remove the marking. If used, marking plates or labels shall show no curling.

NOTE 3 The petroleum spirit to be used for the test is aliphatic solvent hexane having a maximum aromatics content 0,1 % by volume, a kauri-butanol value of 29, an initial boiling point of approximately 65 °C, a dry point of approximately 69 °C and a specific mass of approximately 0,7 kg/l. When using petroleum spirit appropriate environmental, health and safety measures should be applied.

#### **4.3 Location of the marking**

The marking on the product shall be visible but if necessary after removal of a cover. For portable products it shall be possible to remove or open this cover without the aid of a tool, unless health and safety reasons as defined in other directives or standards require that a tool is needed to remove the cover.

If the size or function of the product means that either of the markings defined in 4.1 b) cannot be applied on the product, then the marking shall be printed on the packaging, in the instructions for use and in the warranty of the electrical and electronic equipment.

<http://www.china-gauges.com/>

## Bibliography

93/68/EEC Directive of 22 July 1993 amending Directives 87/404/EEC (simple pressure vessels), 88/378/EEC (safety of toys), 89/106/EEC (construction products), 89/336/EEC (electromagnetic compatibility), 89/392/EEC (machinery), 89/686/EEC (personal protective equipment), 90/384/EEC (non-automatic weighing instruments), 90/385/EEC (active implantable medicinal devices), 90/396/EEC (appliances burning gaseous fuels), 91/263/EEC (telecommunications terminal equipment), 92/42/EEC (new hot-water boilers fired with liquid or gaseous fuels) and 73/23/EEC (electrical equipment designed for use within certain voltage limits)

EN 80416-3:2002, *Basic principles for graphical symbols for use on equipment - Part 3: Guidelines for the application of graphical symbols*

EN 61429:1996/A11:1998, *Marking of secondary cells and batteries with the international recycling symbol ISO 7000-1135 and indications regarding directives 93/86/EEC and 91/157/EEC*

---

<http://www.china-gauges.com/>

<http://www.china-gauges.com/>

## BSI — British Standards Institution

BSI is the independent national body responsible for preparing British Standards. It presents the UK view on standards in Europe and at the international level. It is incorporated by Royal Charter.

### Revisions

British Standards are updated by amendment or revision. Users of British Standards should make sure that they possess the latest amendments or editions.

It is the constant aim of BSI to improve the quality of our products and services. We would be grateful if anyone finding an inaccuracy or ambiguity while using this British Standard would inform the Secretary of the technical committee responsible, the identity of which can be found on the inside front cover.  
Tel: +44 (0)20 8996 9000. Fax: +44 (0)20 8996 7400.

BSI offers members an individual updating service called PLUS which ensures that subscribers automatically receive the latest editions of standards.

### Buying standards

Orders for all BSI, international and foreign standards publications should be addressed to Customer Services. Tel: +44 (0)20 8996 9001.  
Fax: +44 (0)20 8996 7001. Email: [orders@bsi-global.com](mailto:orders@bsi-global.com). Standards are also available from the BSI website at <http://www.bsi-global.com>.

In response to orders for international standards, it is BSI policy to supply the BSI implementation of those that have been published as British Standards, unless otherwise requested.

### Information on standards

BSI provides a wide range of information on national, European and international standards through its Library and its Technical Help to Exporters Service. Various BSI electronic information services are also available which give details on all its products and services. Contact the Information Centre.  
Tel: +44 (0)20 8996 7111. Fax: +44 (0)20 8996 7048. Email: [info@bsi-global.com](mailto:info@bsi-global.com).

Subscribing members of BSI are kept up to date with standards developments and receive substantial discounts on the purchase price of standards. For details of these and other benefits contact Membership Administration.  
Tel: +44 (0)20 8996 7002. Fax: +44 (0)20 8996 7001.  
Email: [membership@bsi-global.com](mailto:membership@bsi-global.com).

Information regarding online access to British Standards via British Standards Online can be found at <http://www.bsi-global.com/bsonline>.

Further information about BSI is available on the BSI website at <http://www.bsi-global.com>.

### Copyright

Copyright subsists in all BSI publications. BSI also holds the copyright, in the UK, of the publications of the international standardization bodies. Except as permitted under the Copyright, Designs and Patents Act 1988 no extract may be reproduced, stored in a retrieval system or transmitted in any form or by any means – electronic, photocopying, recording or otherwise – without prior written permission from BSI.

This does not preclude the free use, in the course of implementing the standard, of necessary details such as symbols, and size, type or grade designations. If these details are to be used for any other purpose than implementation then the prior written permission of BSI must be obtained.

Details and advice can be obtained from the Copyright & Licensing Manager.  
Tel: +44 (0)20 8996 7070. Fax: +44 (0)20 8996 7553.  
Email: [copyright@bsi-global.com](mailto:copyright@bsi-global.com).

BSI  
389 Chiswick High Road  
London  
W4 4AL