

BS EN 71-14:2014



BSI Standards Publication

Safety of toys
Part 14: Trampolines for domestic use

www.china-gauges.com

bsi.

...making excellence a habit.™

National foreword

This British Standard is the UK implementation of EN 71-14:2014.

The UK participation in its preparation was entrusted to Technical Committee CW/15, Safety of toys.

A list of organizations represented on this committee can be obtained on request to its secretary.

This publication does not purport to include all the necessary provisions of a contract. Users are responsible for its correct application.

© The British Standards Institution 2014. Published by BSI Standards Limited 2014

ISBN 978 0 580 79488 9

ICS 97.200.50

Compliance with a British Standard cannot confer immunity from legal obligations.

This British Standard was published under the authority of the Standards Policy and Strategy Committee on 31 December 2014.

Amendments issued since publication

Date	Text affected
------	---------------

EUROPEAN STANDARD

EN 71-14

NORME EUROPÉENNE

EUROPÄISCHE NORM

December 2014

ICS 97.200.50

English Version

Safety of toys - Part 14: Trampolines for domestic use

Sécurité des jouets - Partie 14: Trampolines à usage
familialSicherheit von Spielzeug - Teil 14: Trampoline für den
häuslichen Gebrauch

This European Standard was approved by CEN on 8 November 2014.

CEN members are bound to comply with the CEN/CENELEC Internal Regulations which stipulate the conditions for giving this European Standard the status of a national standard without any alteration. Up-to-date lists and bibliographical references concerning such national standards may be obtained on application to the CEN-CENELEC Management Centre or to any CEN member.

This European Standard exists in three official versions (English, French, German). A version in any other language made by translation under the responsibility of a CEN member into its own language and notified to the CEN-CENELEC Management Centre has the same status as the official versions.

CEN members are the national standards bodies of Austria, Belgium, Bulgaria, Croatia, Cyprus, Czech Republic, Denmark, Estonia, Finland, Former Yugoslav Republic of Macedonia, France, Germany, Greece, Hungary, Iceland, Ireland, Italy, Latvia, Lithuania, Luxembourg, Malta, Netherlands, Norway, Poland, Portugal, Romania, Slovakia, Slovenia, Spain, Sweden, Switzerland, Turkey and United Kingdom.



EUROPEAN COMMITTEE FOR STANDARDIZATION
COMITÉ EUROPÉEN DE NORMALISATION
EUROPÄISCHES KOMITEE FÜR NORMUNG

CEN-CENELEC Management Centre: Avenue Marnix 17, B-1000 Brussels

Contents

	Page
Foreword.....	4
1 Scope (see A.1).....	6
2 Normative references.....	6
3 Terms and definitions.....	6
4 General requirements.....	9
4.1 Exemptions from certain requirements in EN 71-1 (see A.2).....	9
4.2 Trampoline categories.....	9
4.3 General requirements for the trampoline construction (see A.3).....	9
4.3.1 Requirements for mini-trampolines (see 4.2).....	9
4.3.2 Requirements for medium and large trampolines (see 4.2).....	10
4.3.3 Requirements for all trampoline categories.....	10
4.4 Durability of materials (see A.4).....	11
4.4.1 Metallic parts.....	11
4.4.2 Non metallic parts.....	11
4.5 Entrapment (see A.5).....	11
4.5.1 Finger entrapment.....	11
4.5.2 Head and neck entrapment.....	11
4.5.3 Foot entrapment.....	12
4.6 Pinching and crushing hazards (see A.6).....	12
4.7 Sharp edges, sharp points and protruding parts.....	13
4.7.1 General.....	13
4.7.2 Sharp edges and sharp points.....	13
4.7.3 Protruding parts.....	13
4.8 Access devices.....	13
4.9 Padding (see A.7).....	13
4.9.1 Padding coverage.....	13
4.9.2 Impact resistance of the frame padding and the suspension system.....	14
4.9.3 Protection of the poles.....	14
4.9.4 Protection of the handrails (for mini-trampolines).....	14
4.10 Strength (see A.8).....	14
4.10.1 Vertical strength of the enclosure.....	14
4.10.2 Frame strength.....	14
4.10.3 Dynamic strength of enclosures.....	14
4.10.4 Strength of the fixations of the padding to the frame.....	14
4.10.5 Static strength of access devices.....	15
4.10.6 Strength of mat, suspension system and frame.....	15
4.11 Mat deflection (see A.9).....	15
4.12 Stability.....	15
5 Warnings, markings and instructions.....	15
5.1 General.....	15
5.2 Warnings and markings on the product (see A.10).....	16
5.2.1 General.....	16
5.2.2 Marking of the centre of the mat.....	16
5.3 Warnings and markings on the packaging.....	17
5.4 Warnings and information in the instructions for use.....	17
5.4.1 Warnings.....	17
5.4.2 Information.....	18

5.4.3	Assembly and maintenance instructions	18
6	Test methods	19
6.1	Dynamic tests	19
6.1.1	Padding impact test (see 4.9.2).....	19
6.1.2	Enclosure and poles impact strength test (see 4.3.3.1 and 4.10.3).....	19
6.2	Strength	21
6.2.1	Vertical strength of the enclosure (see 4.10.1).....	21
6.2.2	Frame strength (see 4.10.2).....	22
6.2.3	Strength test of mat, suspension system and frame (see 4.10.6).....	24
6.2.4	Strength of the padding fixations to the frame (see 4.10.4).....	24
6.2.5	Static strength of access devices (see 4.10.5).....	24
6.3	Stability (see 4.12)	24
6.3.1	Stability of the frame	24
6.3.2	Enclosure and poles impact stability test.....	25
6.4	Testing of the assembly (see 4.3.3.1 and 4.3.3.2)	26
6.5	Durability tests (see 4.4)	27
6.5.1	Metallic parts (see 4.4.1)	27
6.5.2	Non metallic parts	27
6.6	Mat deflection test (see 4.6, 4.9.1 and 4.11).....	27
Annex A	(informative) Rationale.....	29
A.1	Scope (see Clause 1).....	29
A.2	General (see 4.1 and 4.3.3)	29
A.3	Enclosures (see 4.3).....	29
A.4	Durability of materials (see 4.4).....	31
A.5	Entrapment (see 4.5).....	31
A.6	Pinching and crushing hazards (see 4.6).....	31
A.7	Padding (see 4.9).....	32
A.8	Strength test (see 4.10).....	32
A.9	Mat deflection (see 4.11).....	32
A.10	Warnings and markings on the product (see 5.2).....	32
Annex ZA	(informative) Relationship between this European Standard and the Essential Requirements of EU Directive 2009/48/EC on the safety of toys	33
	Bibliography.....	34

Foreword

This document (EN 71-14:2014) has been prepared by Technical Committee CEN/TC 52 "Safety of toys", the secretariat of which is held by DS.

This European Standard shall be given the status of a national standard, either by publication of an identical text or by endorsement, at the latest by June 2015 and conflicting national standards shall be withdrawn at the latest by June 2015.

Attention is drawn to the possibility that some of the elements of this document may be the subject of patent rights. CEN [and/or CENELEC] shall not be held responsible for identifying any or all such patent rights.

This document has been prepared under a mandate given to CEN by the European Commission and the European Free Trade Association, and supports essential requirements of EU Directive 2009/48/EC.

For relationship with EU Directive 2009/48/EC, see informative Annex ZA, which is an integral part of this document.

This European Standard constitutes the 14th part of the European Standard on safety of toys and needs to be read in conjunction with Part 1.

This European Standard, *Safety of toys*, consists of the following parts:

- *Part 1: Mechanical and physical properties;*
- *Part 2: Flammability;*
- *Part 3: Migration of certain elements;*
- *Part 4: Experimental sets for chemistry and related activities;*
- *Part 5: Chemical toys (sets) other than experimental sets;*
- *Part 6: Finger paints — Requirements and test methods;*
- *Part 8: Activity toys for domestic use;*
- *Part 9: Organic chemical compounds — Requirements;*
- *Part 10: Organic chemical compounds — Sample preparation and extraction;*
- *Part 11: Organic chemical compounds — Methods of analysis;*
- *Part 12: N-Nitrosamines and N-nitrosatable substances;*
- *Part 13: Olfactory board games, cosmetic kits and gustative games;*
- *Part 14: Trampolines for domestic use [this document].*

NOTE 1 In addition to the above parts of EN 71, the following guidance documents have been published: the CEN Report, CR 14379, *Classification of toys – Guidelines*; the CEN Technical Report, CEN/TR 15071, *Safety of toys – National translations of warnings and instructions for use in EN 71*, and the CEN Technical Report, CEN/TR 15371, *Safety of toys – Replies to requests for interpretation of EN 71-1, EN 71-2, and EN 71-8*.

NOTE 2 Words in italics are defined in Clause 3 (Terms and definitions). Additional information on the background and rationale for various requirements is given in Annex A.

NOTE 3 Different legal requirements may exist in non-EU countries.

According to the CEN-CENELEC Internal Regulations, the national standards organizations of the following countries are bound to implement this European Standard: Austria, Belgium, Bulgaria, Croatia, Cyprus, Czech Republic, Denmark, Estonia, Finland, Former Yugoslav Republic of Macedonia, France, Germany, Greece, Hungary, Iceland, Ireland, Italy, Latvia, Lithuania, Luxembourg, Malta, Netherlands, Norway, Poland, Portugal, Romania, Slovakia, Slovenia, Spain, Sweden, Switzerland, Turkey and the United Kingdom.

www.china-gauges.com

1 Scope (see A.1)

This European Standard specifies requirements and test methods for trampolines for domestic use, their *access devices* and their *enclosures*, intended for outdoor and/or indoor use above ground level by one person at a time.

The scope of this European Standard excludes:

- trampolines used as gymnastic equipment, covered by EN 13219;
- floating inflatable trampolines, covered by the EN 15649 series;
- trampolines used in public playgrounds;
- inclined *mat* trampolines;
- inflatable trampolines;
- fitness trampolines, including trampolines for medical use;
- trampolines with additional features, e.g. tents, basket ball hoop;
- trampolines for domestic use buried at ground level.

2 Normative references

The following documents, in whole or in part, are normatively referenced in this document and are indispensable for its application. For dated references, only the edition cited applies. For undated references, the latest edition of the referenced document (including any amendments) applies.

EN 71-1:2014, *Safety of toys — Part 1: Mechanical and physical properties*

EN 71-2:2011, *Safety of toys — Part 8: Activity toys for domestic use*

EN 913:2008, *Gymnastic equipment — General safety requirements and test methods*

EN 13219:2008, *Gymnastic equipment — Trampolines — Functional and safety requirements, test methods*

EN ISO 4892-3, *Plastics — Methods of exposure to laboratory light sources — Part 3: Fluorescent UV lamps (ISO 4892-3)*

EN ISO 9227, *Corrosion tests in artificial atmospheres — Salt spray tests (ISO 9227)*

EN ISO 13934-1, *Textiles — Tensile properties of fabrics — Part 1: Determination of maximum force and elongation at maximum force using the strip method (ISO 13934-1)*

3 Terms and definitions

For the purposes of this document, the following terms and definitions apply.

3.1

access device

equipment used for access to, or egress from, the *mat* of a trampoline including, but not limited to, ladders

3.2

bouncing

action considered as normal use of a trampoline consisting of continuous, vertical jumping in which each landing is in close proximity to the previous landing

3.3

enclosure

flexible barrier (constraint) surrounding the trampoline and designed to prevent the user from falling off a trampoline

3.4

enclosure height

distance from the surface of the *mat* to the lowest point of the brim of the enclosure

Note 1 to entry: The *enclosure height* is illustrated in Figure 1:

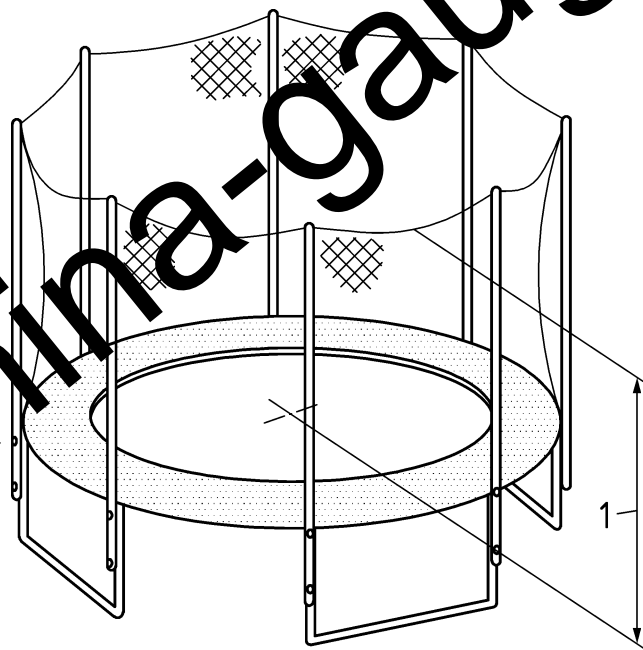

Key

1 enclosure height

Figure 1 — Enclosure height

3.5

frame

construction of rigid supportive materials from which the *mat* is suspended

Note 1 to entry: Example of domestic trampoline including trampoline *frame* and *mat* (see Figure 3).

3.6

legs

part of the framework, constructed of rigid materials which support the *frame*

3.7

mat

predominantly flexible surface which the user contacts in the course of *bouncing* on the trampoline

Note 1 to entry: Example of domestic trampoline including trampoline *frame* and *mat* (see Figure 3).

3.8
maximum user weight

mass, in kilograms, indicated by the manufacturer as the maximum weight of a user

3.9
padding

shock-attenuating protective system attached to the *frame* to cover the *frame* and the *suspension system*

Note 1 to entry: Example of domestic trampoline including trampoline *frame* and *mat* (see Figure 3).

3.10
suspension system

mechanism that supports the *mat*, consisting of flexible devices that connect the *mat* to the *frame*

Note 1 to entry: Steel extension springs are a typical example of a *suspension system* (see Figure 2).



Figure 2 — Example of a suspension system

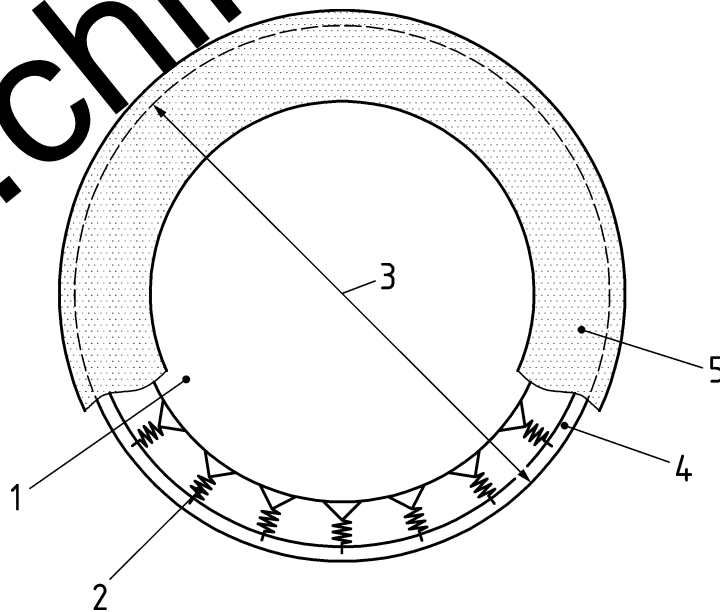

Key

- 1 *mat*
- 2 *suspension system*
- 3 *frame size* (in case of a non-circular *trampoline* the *frame size* is the maximum distance between two opposite points of the *frame*)
- 4 *frame*
- 5 *padding*

Figure 3 — Example of trampoline frame and mat

4 General requirements

4.1 Exemptions from certain requirements in EN 71-1 (see A.2)

The requirements in EN 71-1 are applicable to trampolines for domestic use with exemptions for the requirements under the following headings in EN 71-1:

- edges (EN 71-1:2014, 4.7);
- sharp points (EN 71-1:2014, 4.8);
- protruding parts (EN 71-1:2014, 4.9);
- toys which a child can enter (EN 71-1:2014, 4.14.1).

The above mentioned requirements from EN 71-1 are not exempted for trampolines intended for children under 36 months.

NOTE This European standard specifies specific requirements for edges, sharp points and protruding parts for trampolines for domestic use which is why the corresponding requirements of EN 71-1 do not apply to trampolines (for children of 36 months and over).

4.2 Trampoline categories

Trampolines shall be classified by the size, height and *maximum user weight* according to Table 1.

Table 1 — Trampoline size, height and maximum user weight requirements

	Mini	Medium	Large
Frame size in mm	< 1 500	≥ 1 500 < 2 500	≥ 2 500
Frame height in mm	< 350	≥ 350	≥ 350
Maximum user weight in kg	25	50	Manufacturer defined

The *frame size* for a circular trampoline is equal to the diameter (see Figure 3) while for non-circular trampolines it is equal to the maximum distance between two opposite points of the outside of the *frame* (e.g. the largest diagonal in the case of a rectangular trampoline).

If at least one of the measurements in Table 1 is exceeded, the trampoline shall be classified in the closest higher category.

4.3 General requirements for the trampoline construction (see A.3)

4.3.1 Requirements for mini-trampolines (see 4.2)

Mini-trampolines intended for indoor use shall be provided with anti-slip feet. Such trampolines shall not slip when tested according to EN 13219:2008, 5.2.

Mini-trampolines may be equipped with handrails to assist the balance of the user. Mini-trampolines may be equipped with an *enclosure*. If mini-trampolines are equipped with handrails they shall not be equipped with an *enclosure*.

NOTE See 4.3.3.2 for requirements on *enclosures*.

4.3.2 Requirements for medium and large trampolines (see 4.2)

Medium and large trampolines shall be equipped with an *enclosure* but shall not be equipped with a handrail.

NOTE See 4.3.3.2 for requirements on *enclosures*.

4.3.3 Requirements for all trampoline categories

4.3.3.1 General requirements

The construction of the trampoline shall ensure that during play (or movement of the trampoline) the assembled joints cannot become dislodged.

NOTE This requirement can be fulfilled by the use of pit pins or bolts.

After being tested according to 6.4 (testing of the assembly), the legs and the *frame* shall remain in their initial connection position without apparent movement.

The assembled joints of the trampoline and *enclosure*, if any, shall stay connected when tested according to 6.1.2 (enclosure and poles impact string test).

4.3.3.2 Enclosures

The opening of the *enclosure* shall also allow access for an adult.

Any *enclosure* shall allow supervision of the child during play on any point of the periphery of the trampoline.

Access under the trampoline shall be free and the zone between the *mat* and ground shall not be enclosed. No barrier shall be mounted around the trampoline *frame*.

It shall be possible to open the opening in the *enclosure* from the inside and from the outside independently. The opening for access through any *enclosure* shall be easy to distinguish from the rest of the *enclosure*.

NOTE 1 EN 71-1:2014, A.33 contains Good practices for visibility and legibility for warnings. Some of the recommendations given in this annex could also be applied for distinguishing the opening for access from the rest of the *enclosure*.

If buckles are used for the opening, the opening force needed for opening each (single) buckle shall be 50 N or less.

If a zip is used for the opening, the opening-direction the zip shall be from bottom to top.

The slider of any zip or any other means of opening shall be of a colour which contrasts with the colour of the teeth and ribbons of the zip, unless a conspicuous handle of a different colour is attached to the slider.

NOTE 2 This requirement can be fulfilled by having a double-tagged slider on a zip-fastener.

The height of the *enclosure* shall be:

- at least 1,5 m for trampolines with a *frame* size of less than 2,5 m;

- at least 1,8 m for trampolines with a *frame* size of 2,5 m or more.

When tested according to 6.4 (testing of the assembly), no element supporting the *enclosure* (e.g. poles, liaison tubes, caps) shall dismantle.

4.4 Durability of materials (see A.4)

4.4.1 Metallic parts

This requirement does not apply to mini-trampolines (see 4.2 (trampoline categories)), if designed for indoor use only, and not to stainless metals (aluminium alloy or copper or stainless steel).

When tested in accordance with 6.5.1 (durability test, metallic parts), all structural metallic parts as well as metal fasteners and fixing mechanisms, coated or non-coated, shall present less than 1/10:th of red-rusted surface area. White rust is accepted.

4.4.2 Non metallic parts

Before and after being tested according to 6.5.2 (durability test, non metallic parts), the outermost material of the *padding* system for the *frame* and the material of the *enclosure* shall have a 'maximum force' (as defined in EN ISO 13934-1) of at least 150 N. Before and after being tested according to 6.5.2 (durability test, non metallic parts), the mat shall all retain at least 80 % of their maximum force (as defined in EN ISO 13934-1). The requirement applies to two sets of test specimens (one in the warp and one in the weft direction) as specified in EN ISO 13934-1.

4.5 Entrapment (see 5)

4.5.1 Finger entrapment

This requirement applies to any rigid openings accessible during bouncing.

Accessible holes, slots and gaps in any rigid material that are within the reach of a child during use of the toy when the body of the child is in a forced movement, shall not allow a 7 mm diameter rod to be inserted to a depth of 10 mm or more, unless a 12 mm diameter rod can also be inserted.

If a trampoline is intended for children under 36 months, the accessible holes, slots or gaps in any rigid material that are within the reach of a child during use of the toy when the body of the child is in a forced movement, shall not allow a 5 mm diameter rod to be inserted to a depth of 10 mm or more unless a 12 mm diameter rod can also be inserted.

4.5.2 Head and neck entrapment

Trampolines shall be constructed so that no openings create head and neck *entrapment* hazards either by head first or feet first passage. When choosing materials, the manufacturer shall also take into account the *entrapment* hazards that can occur due to distortion of material during use.

NOTE Hazardous situations in which this type of entrapment can be encountered include the following:

- completely bound openings through which a user can slide head first or feet first;
- partially bound or V-shaped openings;
- shearing and moving openings.

Any such openings shall comply with the following requirements:

- a) all accessible completely bound openings with a lower edge of 600 mm or more above the ground, or above any other surface which is of such a size that it will support a child, shall, if they allow passage of probe C under a maximum force of 222 N, also allow passage of probe D under a maximum force of 222 N when tested according to EN 71-8:2011, 6.5.1 (head and neck entrapment in accessible completely bound openings). The test probes shall be applied in the downward direction of the user (feet first);
- b) accessible rigid circular openings with a lower edge of 600 mm or more above the ground, or above any other surface which is of such a size that it will support a child, shall not have an internal diameter between 130 mm and 230 mm;
- c) accessible completely bound openings that allow the free passage of probe C, when tested according to EN 71-8:2011, 6.5.1 (head and neck entrapment in accessible completely bound openings), shall have no parts that converge in the downward direction at an angle of less than 60° if the lower edge is 600 mm or more above the ground (V-shaped opening);
- d) partially bound and V-shaped openings with a lower edge of 600 mm or more above the ground, or above any other surface which is of such a size that it will support a child shall be constructed so that either:
 - 1) the opening is not accessible as defined in EN 71-8:2011, Figure 20, when tested according to EN 71-8:2011, 6.5.2.3 a) (head and neck entrapment in partially bound and V-shaped openings), or
 - 2) the tip of template E (see EN 71-8:2011, Figure 19) contacts the base of the opening, when tested according to EN 71-8:2011, 6.5.2.3 b) (head and neck entrapment in partially bound and V-shaped openings).

4.5.3 Foot entrapment

Surfaces intended for bouncing and standing shall not contain any gaps greater than 30 mm measured in one direction (see Figure 4).

This requirement does not apply to junctions between two consecutive sections of the *padding*. (Unless this space is ≤ 30 mm).

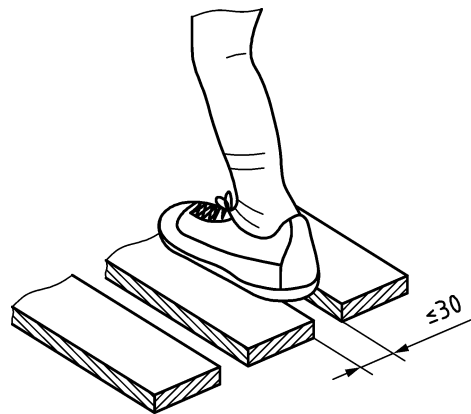

Figure 4 — Measurement of surface gap on bouncing and walking levels

4.6 Pinching and crushing hazards (see A.6)

When tested according to 6.6 (mat deflection test), *suspension systems* shall not be accessible if the gap between two consecutive moving parts is greater than 3 mm (e.g. between two consecutive springs spirals).

NOTE This requirement can be fulfilled by making the springs inaccessible during *bouncing* or by using elastic materials other than springs.

The accessibility of a part shall be tested in accordance with EN 71-1:2014, 8.10 (accessibility of a part or component).

4.7 Sharp edges, sharp points and protruding parts

4.7.1 General

The accessibility of a part shall be tested in accordance with EN 71-1:2014, 8.10 (accessibility of a part or component).

4.7.2 Sharp edges and sharp points

After assembly in accordance with the instructions for use, there shall be no sharp edges or sharp points on the accessible parts of the trampoline when tested according to EN 71-1:2014, 8.11 (sharpness of edges) and EN 71-1:2014, 8.12 (sharpness of points).

4.7.3 Protruding parts

After assembly according to the instructions for use, protruding parts on trampolines and *enclosures* shall comply with EN 71-8:2011, 4.1.5 (protruding parts).

4.8 Access devices

When provided together with the trampoline, any *access device* shall comply with EN 71-8:2011, 4.2.2 (ladders and similar means of access to activity toys).

The *access device* shall be capable of being fixed to the trampoline, when in use, to prevent it from slipping. It shall be possible to remove the *access device* from the trampoline without the use of a tool.

The requirements of 4.8 apply also to *access devices* sold separately. For *access devices* sold separately, information regarding which type and size of trampoline the *access device* is intended for shall be visible at the point of sale.

4.9 Padding (see A.7)

4.9.1 Padding coverage

Every surface (apart from the *mat* and *access device*) where a child could stand or sit shall be covered by *padding*.

The *padding* shall cover the entire top surface of the *frame*. After being loaded according to 6.6 (mat deflection test), the *padding* shall cover the entire top surface of the *frame*, and shall overlap the *mat* with a minimum of 10 mm (if applicable), and the entire top surface of the *frame* shall remain covered by the *padding* (see Figure 5).

The distance between any two adjacent shock absorbing pieces of material within the padding shall not be greater than 40 mm.

Either the *padding* shall be of a colour which contrasts with the colour of the *mat*, or the borderline between the *mat* and the *padding* shall be clearly marked with a 50 mm wide border in a contrasting colour. This requirement does not apply to trampolines where the protective *padding* is entirely outside the *enclosure*.

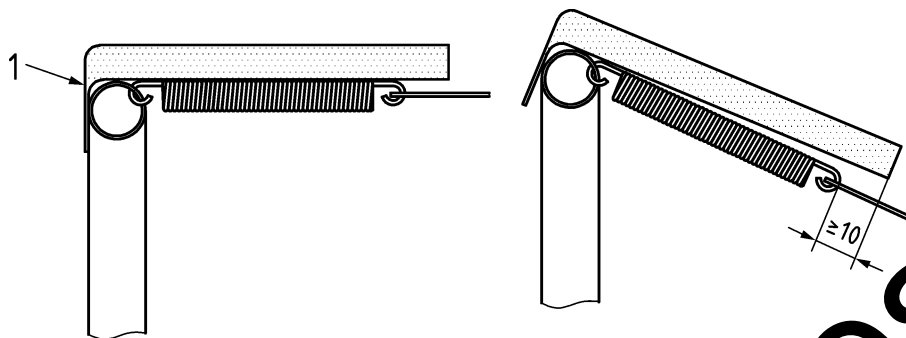

Key

1 upper frame protection

Figure 5 — Example of padding coverage

4.9.2 Impact resistance of the frame padding and the suspension system

When tested according to 6.1.1 (padding impact test), the impact on the *frame padding* and on the *suspension system*, shall not show a peak acceleration exceeding 500 m/s^2 .

4.9.3 Protection of the poles

Rigid poles shall be protected with a resilient and flexible material (e.g. textile, ethylene vinyl acetate (EVA) or flexible rubber).

4.9.4 Protection of the handrails (for mini-trampolines)

Handrails (if any) shall be protected with a resilient and flexible material (e.g. textile, ethylene vinyl acetate (EVA) or flexible rubber).

For mini-trampolines with a handle, the *padding* shall cover the entire top surface of the handle.

4.10 Strength (see A.8)

4.10.1 Vertical strength of the enclosure

The trampoline shall not collapse when tested according to 6.2.1 (vertical strength of the enclosure).

4.10.2 Frame strength

Trampolines shall not collapse when tested according to 6.2.2 (frame strength).

4.10.3 Dynamic strength of enclosures

When tested according to 6.1.2 (enclosure and poles impact strength test), all parts of the trampoline shall continue to conform to the relevant requirements of this standard.

4.10.4 Strength of the fixations of the padding to the frame

After assembly of the *padding* according to the instructions for use, and tested according to 6.2.4 (strength of the padding fixations to the frame) the fixations system of the *padding* shall not break or become detached.

4.10.5 Static strength of access devices

When tested according to 6.2.5 (static strength of access devices), the *access devices* shall not collapse so that they do not conform to relevant requirements of this European Standard.

4.10.6 Strength of mat, suspension system and frame

When tested according to 6.2.3 (strength test of mat, suspension system and frame):

- the *mat* material, and any sewn, welded or glued joints, as well as subsidiary attachment items (usually but not exclusively triangular or “D”-shaped metal rings), shall show no sign of tearing, splitting or cracking. The requirement is checked by visual inspection;
- the material of the *mat* and attachment system shall not present any failure or rupture.

4.11 Mat deflection (see A.9)

When tested according to 6.6 (mat deflection test):

- the maximum deflection shall not exceed 80 % of the distance between the *mat* (at rest) and the ground;
- in addition, for all trampolines, the distance from the ground to the *mat* shall be at least 100 mm.

4.12 Stability

The trampoline shall not tip over when tested according to 6.3 (stability).

Trampolines which have fixation devices that, according to the instructions for use, shall not be permanently fixed (e.g. in concrete) shall be tested with the fixation devices anchored in the ground or surface according to the instructions for use.

The requirement in 4.12 does not apply to trampolines which have fixation devices which according to the instructions for use shall be permanently fixed (e.g. in concrete).

5 Warnings, markings and instructions

5.1 General

The warnings shall be preceded by the word: “Warning” or “Warnings”, as appropriate (i.e. instead of repeating the word “Warning” before each warning when several of the required warnings are present, the word “Warnings” may be used once), and be clearly visible to the consumer before the purchase. The word “Warning” or “Warnings” may be followed by punctuation, e.g. an exclamation mark.

5.1.1 Warning regarding domestic use.

The trampoline or its packaging shall carry the following warning which shall be clearly visible at the point of sale:

“Warning. Only for domestic use”.

5.1.2 Warning regarding trampolines not intended for children under 36 months.

When applicable, trampolines for domestic use shall comply with the warning requirement in EN 71-1:2014, 7.2. As indicated in EN 71-1, a brief indication of the specific hazard calling for the restriction (i.e. the warning) shall also be given.

5.2 Warnings and markings on the product (see A.10)

5.2.1 General

In addition to applicable warnings in 5.1, the following warnings shall be visible when the user is standing in front of the entrance/access device:

- “Warning. Max xx kg”;
- “Warning. Only one user. Collision hazard”;
- “Warning. Adult supervision required”;
- “Warning. [Indicate whether the trampoline is intended for indoor and/or outdoor use]”;
- “Warning. No somersaults”;
- “Warning. Always close the net opening before jumping”;
- “Warning. Read the instruction”.
- “Warning. The net should be replaced every (x) year(s)”.

(*) The time is to be specified by the manufacturer.

5.2.2 Marking of the centre of the mat

The centre of the *mat* of a medium or large trampoline shall be clearly marked in a colour contrasting to the *mat* and the mark used shall have a minimum size of 150 mm and a maximum size of 600 mm (see example in Figure 6). It is acceptable to use the manufacturer's logotype to mark the centre of the *mat*. In cases where the shape of the logotype is irregular and does not have a clear centre-point, the logotype shall be positioned as centred as possible and fully inside a fictive circle which has a diameter of 800 mm and is centred over the geometric centre of the *mat* (see example in Figure 6).

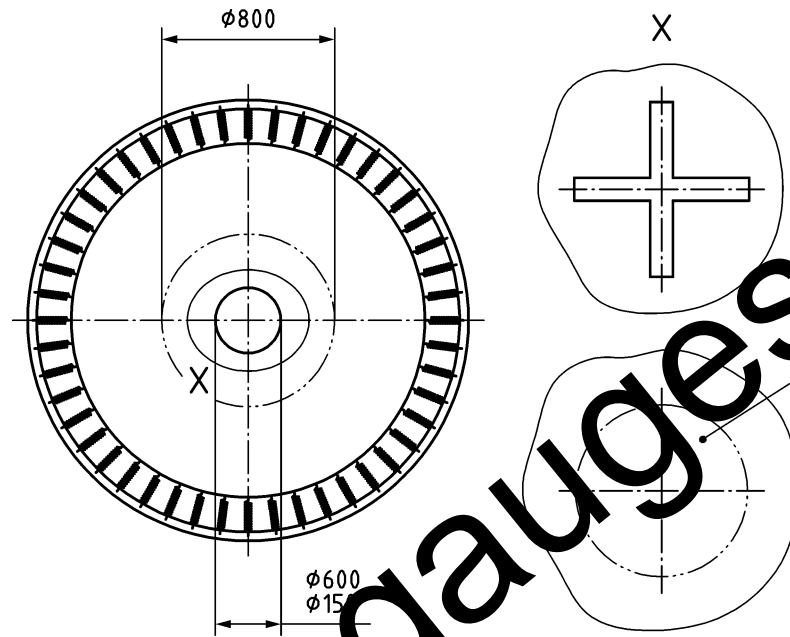

Key

1 logo

Figure 6 — Example of marking of the centre of the mat on a circular trampoline

5.3 Warnings and markings on the packaging

In addition to applicable warnings in 5.1, the following warnings shall be marked on the packaging and/or be clearly visible at the point of sale:

- “Warning. Max xx kg”;
- “Warning”. [Indicate whether the trampoline is intended for indoor and/or outdoor use];
- “Warning. Only one user. Collision hazard”;
- “Warning. The net should be replaced every (*) year(s)”.

(*) The time is to be specified by the manufacturer.

In addition, the main dimensions of the assembled product and the free space required around the trampoline shall be clearly indicated on the packaging and/or be clearly visible at the point of sale.

5.4 Warnings and information in the instructions for use

5.4.1 Warnings

The following warnings shall as a minimum be included in the instructions for use:

- “Warning. Max xx kg”;
- “Warning”. [Indicate whether the trampoline is intended for indoor and/or outdoor use];
- “Warning. The trampoline shall be assembled by an adult in accordance with the assembly instructions and thereafter checked before the first use”;

- “Warning. Only one user. Collision hazard”;
- “Warning. Always close the net opening before jumping”;
- “Warning. Jump with/without shoes [as decided by the manufacturer]”;
- “Warning. Do not use the *mat* when it is wet”;
- “Warning. Empty pockets and hands before jumping”;
- “Warning. Always Jump in the middle of the *mat*”;
- “Warning. Do not eat while jumping”;
- “Warning. Do not exit by a jump”;
- “Warning. Limit the time of continuous usage (make regular stops)”;
- “Warning. Do not use in strong wind conditions and secure the trampoline”.

5.4.2 Information

In addition to the warnings in 5.4.1, the following information shall as a minimum be included in the instructions for use:

- instructions that the trampoline is not intended to be buried into the ground;
- an indication of product dimensions;
- jumping instructions;
- instructions on how to move the trampoline;
- a recommendation to place the trampoline on a level surface at least 2 m from any structure or construction such as a fence, garage, house, overhanging branches, laundry lines or electrical wires;
- instructions that trampolines shall neither be installed over concrete, asphalt or any other hard surface nor at proximity of other conflicting installations (e.g. paddling pools, swings, slides, climbing *frames*);
- instructions that modifications made by the consumer to the original trampoline (e.g. the adding of an accessory) shall be carried out according to the instructions of the manufacturer.

5.4.3 Assembly and maintenance instructions

In addition to the warnings in 5.4.1 and the instructions in 5.4.2, the instructions for use shall include detailed instructions for assembly as well as maintenance instructions.

The maintenance instructions shall draw attention to the need to carry out checks and maintenance of the main parts (*frame, suspension system, mat, padding, and enclosure*) at the beginning of each season and also at regular intervals, pointing out that if these checks are not carried out, the trampoline could become dangerous.

In addition, the maintenance instructions shall, as appropriate, include the following recommendations:

- check all nuts and bolts for tightness and tighten when required;

- check that all spring-loaded (pit pin) joints are still intact and cannot become dislodged during play;
- check all coverings and sharp edges and replace when required;
- retain the maintenance instruction manual;
- Outdoor trampolines should be equipped with a device that in strong wind conditions avoid displacement due to wind (e.g. steel bars in the ground or loads like sand bag or water bags) and/or parts catching wind like net and mat should be removed;
- in certain countries during winter period, the snow load and the very low temperature can damage the trampoline. It is recommended to remove the snow and store the *mat* and the *enclosure* indoor;
- check that *mat*, *padding* and *enclosure* are without defects;

NOTE Sunlight, rain, snow and extreme temperatures reduce the strength of these parts over time.

- replace the net and /or *enclosure* after (*) year(s) of use;
- make sure that the hook-and-loop fasteners are closed correctly during use of trampoline.

(*) The time is to be specified by the manufacturer.

The manufacturer shall provide information on how to secure the trampoline at strong wind conditions, e.g. removing items (net etc.) and/or fixing the trampoline to the ground.

6 Test methods

6.1 Dynamic tests

6.1.1 Padding impact test (see 4.9.2)

Install the trampoline and *padding* according to the instructions for use.

Apply the test method specified in EN 913:2008, 5.5 (shock absorption of top padding).

The drop height of the impactor shall be (200 ± 5) mm.

This falling test shall be performed once at 10 different positions which represent the most onerous positions.

Discard the two extreme recorded values and average the eight remaining values.

Determine whether the average value exceeds 500 m/s^2 .

6.1.2 Enclosure and poles impact strength test (see 4.3.3.1 and 4.10.3)

See Figure 7 for illustration of the test method.

Ensure that the trampoline is fixed, at ground level, on the side opposite to the point of impact at one or two feet, e.g. by clamping.

The test shall be performed with a pendulum device.

The bag shall have a height of (900 ± 50) mm and a diameter of (330 ± 30) mm with a sand filling (e.g. sand with grain size (0-4) mm, specific gravity of approximately $1\,540 \text{ kg/m}^3$). The mass of the sand filled bag shall

be (120 ± 1) kg. The centre of gravity of the sand filled bag shall be in the geometrical centre of the bag (with a tolerance in all directions of 50 mm).

NOTE 1 Humidity can affect the weight of the sand filled bag.

Suspend the bag from a chain or wire. The pivot point (see key 1 of Figure 7) of the pendulum created by the load and chain or wire shall be positioned directly above the impact point of the bag with the enclosure. Then the pivot point shall be displaced towards the centre of the mat with the distance corresponding to half of the diameter of the bag (see Figure 7). Fix the pivot point at a height of (500 ± 50) mm above the enclosure height.

The pendular movement shall be such that the centre of gravity of the bag drops from a height h_2 calculated with the following formula vertically from the release position of the bag to the position where it impacts the enclosure.

$$h_2 = \frac{m_{muw} \cdot 300 \text{ mm}}{120 \text{ kg}}$$

where

h_2 is the height which the centre of gravity drops, in mm;

m_{muw} is the *maximum user weight*, in kg.

NOTE 2 A.3 contains a table of calculated heights h_2 for commonly used *maximum user weights*.

The impact points shall be at three different locations along the vertical centre of the enclosure (i.e. the mid-point of the enclosure height):

- in the most onerous position between 2 poles;
- on a pole;
- the vertical centre of the enclosure opening (door).

The test shall be performed twice at each impact point.

Determine whether the assembled joints of the trampoline and enclosure are still connected and whether all parts of the trampoline continue to conform to the relevant requirements of this European Standard.

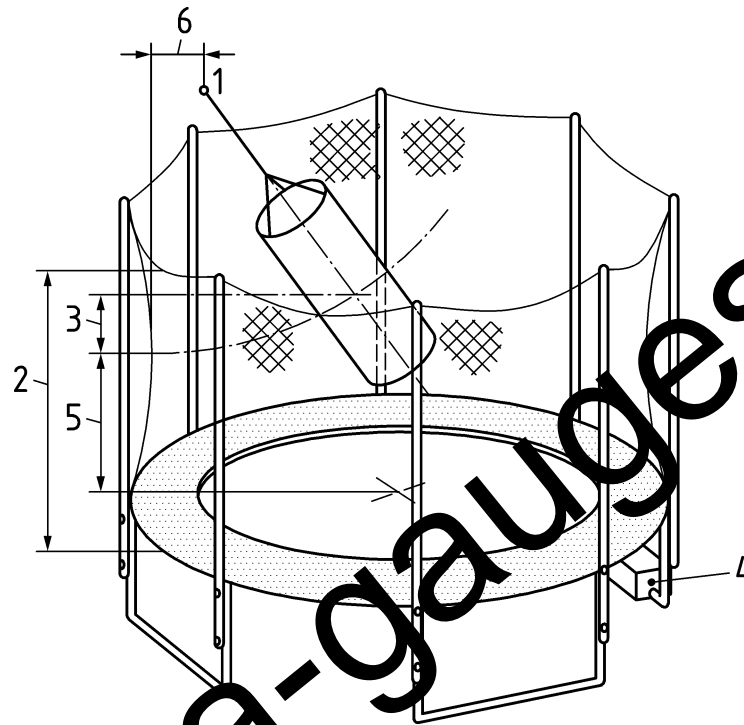

Key

- 1 pivot point of the pendulum
- 2 enclosure height (h_e)
- 3 vertical distance to the any fixed point of the bag drops during the test
- 4 block
- 5 mid-point of enclosure height ($h_e/2$)
- 6 (horizontal) distance of the pivot point to the enclosure (corresponds to half the diameter of the bag)

Figure 7 — Enclosure and pole impact strength test

6.2 Strength

6.2.1 Vertical strength of the enclosure (see 4.10.1)

For trampolines designed with a rigid top frame of the enclosure, load the frame in the most onerous position with a $(50 \pm 0,5)$ kg mass fixed with a (500 ± 10) mm spaced bracket for a duration of 1 min (see Figure 8).

Determine whether the *frame* collapses.

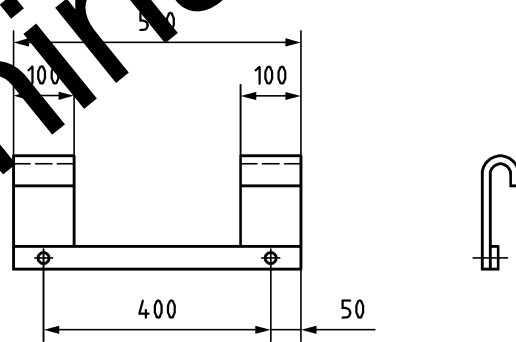
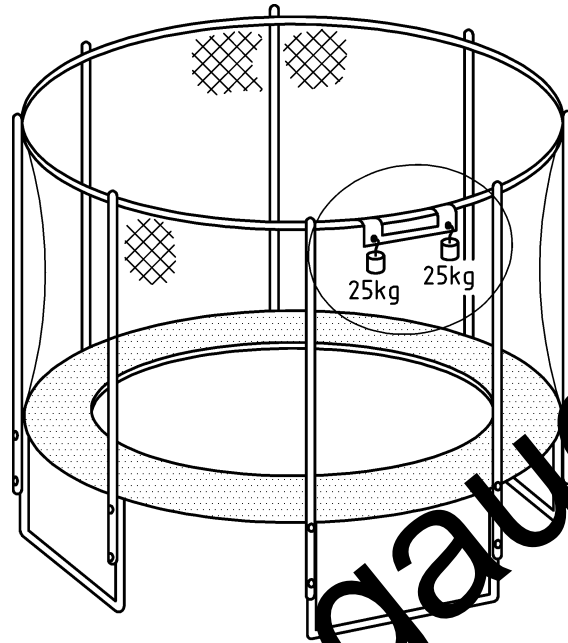

Figure 8 — Example of suspended mass

6.2.2 Frame strength (see 4.10.2)

Assemble the trampoline according to the instructions for use and place it on a hard horizontal surface.

Position the test load on a (330 ± 10) mm diameter rigid disc at the most onerous position of the *frame* (see example in Figures 9 and 10).

- For a medium or large trampoline (see 4.2 (trampoline categories)), pre-load the *frame* at the most onerous position with a mass of $(30 \pm 0,5)$ kg for 1 min.
- For a mini-trampoline (see 4.2 (trampoline categories)), pre-load the *frame* at the most onerous position with a mass of $(10 \pm 0,2)$ kg for 1 min.

NOTE The most onerous position is generally the centre point of the *frame* between two adjacent *legs*.

The centre of gravity of the load shall be in line with the geometric centre of the rigid disc.

Gradually increase the load to 1,5 times the indicated *maximum user weight*, with a tolerance of $-0 \% / + 5 \%$;

Maintain the load for 5 min.

Determine whether the trampoline collapses.

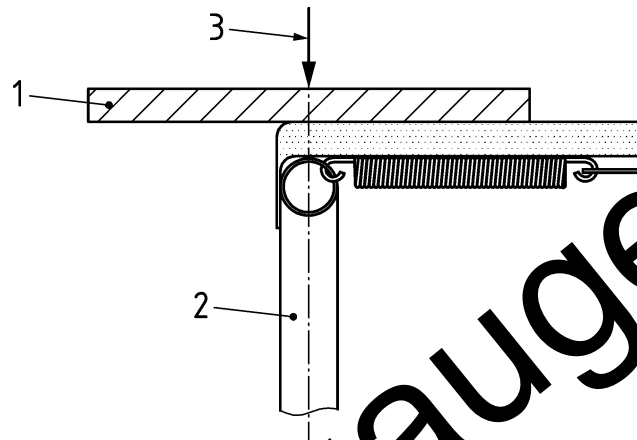

Key

- 1 330 mm rigid disc
- 2 trampoline *frame*
- 3 test load

Figure 9 — Position of the load (side view)

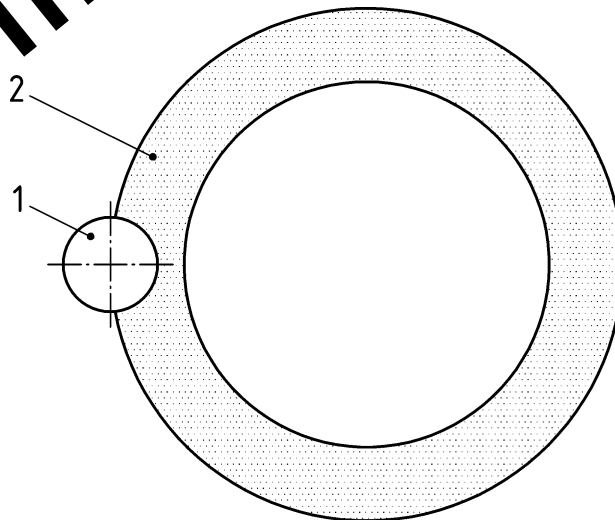

Key

- 1 trampoline *padding*
- 2 330 mm rigid disc

Figure 10 — Top view of the loading test

6.2.3 Strength test of mat, suspension system and frame (see 4.10.6)

Assemble the trampoline according to the instructions for use and place it on a hard horizontal surface.

Calculate the test load (t) according to the following formula:

$$t \text{ (kg)} = 4 \times \text{maximum user weight (kg)}$$

Load the geometric centre of the *mat*, on a (330 ± 10) mm diameter rigid disc, with a mass to the nearest 0,5 kg equal to the calculated value. The centre of gravity of the load shall be in line with the geometric centre of the rigid disc.

Inspect (visually) whether the *mat* material, and any sewn, welded or glued joints, as well as subsidiary attachment items show any sign of tearing, splitting or cracking. Determine whether the *mat* and attachment system present any failure or rupture.

6.2.4 Strength of the padding fixations to the frame (see 4.10.6)

Apply a horizontal force of (150 ± 2) N in line with the fixation(s) of the *padding* to the *frame* toward the geometrical centre of the *mat*.

Apply this force gradually over a 5 s period.

Maintain the force during 10 s.

Determine if the fixation system breaks or can be detached.

6.2.5 Static strength of access devices (see 4.10.5)

Position the test load (1,5 times the indicated *maximum user weight*) on a (330 ± 10) mm diameter rigid disc in the most onerous position of the tread or rung.

NOTE The most onerous position is generally the centre point of the tread or the rung.

The centre of gravity of the load shall be in line with the geometric centre of the rigid disc.

Maintain the load for 5 min.

Determine whether the *access device* collapses so that it does not conform to the relevant requirements of this European Standard.

6.3 Stability (see 4.12)

6.3.1 Stability of the frame

Assemble the trampoline according to the instructions for use and place it on a hard horizontal surface.

Position the test load on a (330 ± 10) mm diameter rigid disc at the most onerous position of the *frame*.

— For a medium or large trampoline (see 4.2 (trampoline categories)), pre-load the *frame* in the most onerous position with a mass of $(30 \pm 0,5)$ kg for 1 min.

— For a mini-trampoline (see 4.2 (trampoline categories)), pre-load the *frame* in the most onerous position with a mass of $(10 \pm 0,2)$ kg for 1 min.

NOTE The most onerous position is generally the centre point of the *frame* between 2 adjacent *legs*.

The centre of gravity of the load shall be in line with the geometric centre of the rigid disc.

Gradually increase the load to 1,5 times the indicated *maximum user weight*, with a tolerance of -0 % / +5 %.

Maintain the load for 5 min.

Determine whether the trampoline tips over during the test.

6.3.2 Enclosure and poles impact stability test

See Figure 11 for illustration of the test method.

For a trampoline without fixation devices, stops shall be used to prevent it from slipping on the surface during the test. However, stops shall not prevent the trampoline from overturning.

The test shall be performed with a pendulum device.

The bag shall have a height of (900 ± 50) mm and a diameter of (330 ± 30) mm with a sand filling (e.g. sand with grain size (0-4) mm, gravity of approximately 1.640 g cm^{-3}). The mass of the sand filled bag shall be (120 ± 1) kg. The centre of gravity of the sand filled bag shall be in the geometrical centre of the bag (with a tolerance in all directions of 50 mm).

NOTE 1 Humidity can affect the weight of the sand filled bag.

Suspend the bag from a chain or wire. The pivot point (see key 1 of Figure 11) of the pendulum created by the load and chain or wire shall be positioned directly above the impact point of the bag with the *enclosure*. Then the pivot point shall be displaced towards the centre of the mat with the distance corresponding to half of the diameter of the bag (see Figure 11). Fix the pivot point at a height of (500 ± 50) mm above the *enclosure height*.

The pendular movement shall be such that the centre of gravity of the bag drops from a height h_2 calculated with the following formula vertically from the release position of the bag to the position where it impacts the *enclosure*.

$$h_2 = \frac{m_{muw} \cdot 300 \text{ mm}}{120 \text{ kg}}$$

where

h_2 is the height which the centre of gravity drops, in mm;

m_{muw} is the *maximum user weight*, in kg.

NOTE 2 A.3 contains a table of calculated heights for commonly used *maximum user weights*.

The impact points shall be at three different locations along the vertical centre of the *enclosure* (i.e. the midpoint of the *enclosure height*):

- in the most onerous position between 2 poles;
- on a pole;
- at the vertical centre of the *enclosure* opening (door).

Determine whether the trampoline tips over.

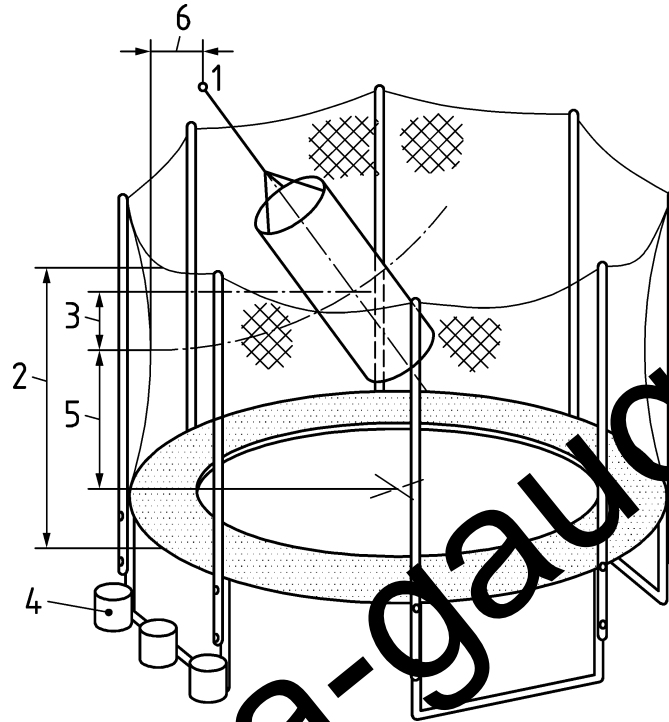

Key

- 1 pivot point of the pendulum
- 2 enclosure height (h_e)
- 3 vertical distance h that any fixed point of the bag drops during the test
- 4 block
- 5 mid-point of enclosure height ($h_e/2$)
- 6 (horizontal) distance of the pivot point to the enclosure (corresponds to half the diameter of the bag)

Figure 11 — Enclosure and poles impact stability test

4.4 Testing of the assembly (see 4.3.3.1 and 4.3.3.2)

Load two adjacent *legs* with a mass of $(10 \pm 0,1)$ kg per *leg* (see Figure 12).

Slowly, lift up the *frame* with the loads installed to a vertical distance of (200 ± 10) mm from the initial position and maintain this position for 30 s before returning to the initial position.

Determine whether the *legs* and the *frame* remain in their initial connection position without apparent movement.

Apply a 60 N tension force on each junction of each element supporting the *enclosure* (e.g. poles, tubes, caps).

Determine whether any element supporting the *enclosure* (e.g. poles, liaison tubes, caps) dismantles.

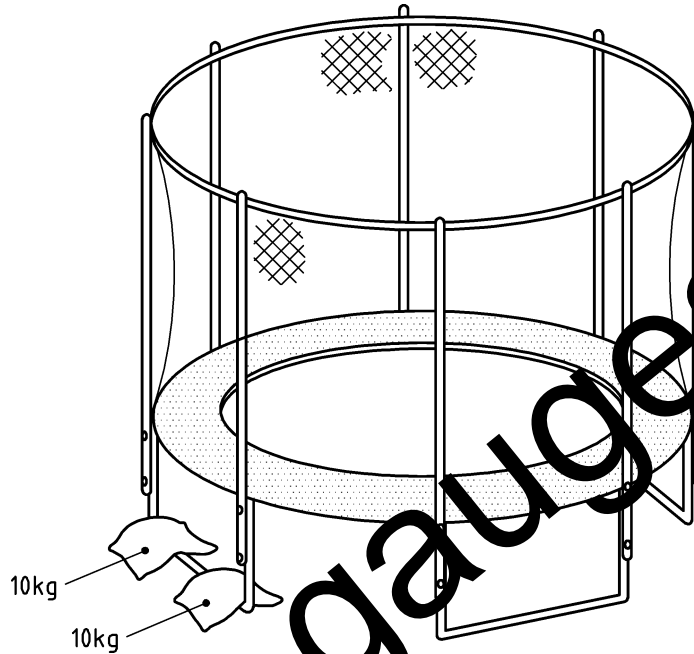

Figure 12 Example of loading of the legs

6.5 Durability tests (see 4.4)

6.5.1 Metallic parts (see 4.4.1)

Subject the parts covered by the requirements in 4.4.1, to a 48 h neutral salt spray test (5 % sodium chloride solution) in accordance with EN ISO 9227. Determine the percentage of the surface area which is red-rusted.

6.5.2 Non-metallic parts

Subject the parts covered by the requirements in 4.4.2, to fluorescent UV-radiation in accordance with EN ISO 4892-3, using Method A, Cycle No. 1, for a total of 400 h.

Before and after subjecting materials covered by 4.4.2 to the test in 6.5.2 (durability test, non metallic parts), determine their 'maximum force' in accordance with EN ISO 13934-1, using a clamp with a width of (50 ± 2) mm. Apply the test to the two sets of test specimens (cut in two different directions) specified in EN ISO 13934-1.

Determine whether the 'maximum force', is at least 150 N (before and after testing to 6.5.2 (durability test, non metallic parts)).

If a sample during a test has been materially affected by a clamp or similar test equipment, a new test shall be performed on a new sample.

6.6 Mat deflection test (see 4.6, 4.9.1 and 4.11)

Assemble the trampoline according to the instructions for use and place it on a hard horizontal surface.

Measure, to the nearest 5 mm, the vertical distance between the hard surface and the unloaded *mat* (h) (see Figure 13).

Calculate the test load (F) according to the following formula:

$$F \text{ (kg)} = 2,5 \times \text{maximum user weight (kg)} \quad (2)$$

Load the geometric centre of the *mat*, on a (330 ± 10) mm diameter rigid disc, with a mass to the nearest 0,5 kg equal to the calculated value. The centre of gravity of the load shall be in line with the geometric centre of the rigid disc. After 10 min, measure the deflection of the *mat* (d) to the nearest 5 mm (see Figure 13).

Calculate the percentage deflection (d) using the following formula:

$$d \text{ (\%)} = 100 \times d/h \quad (3)$$

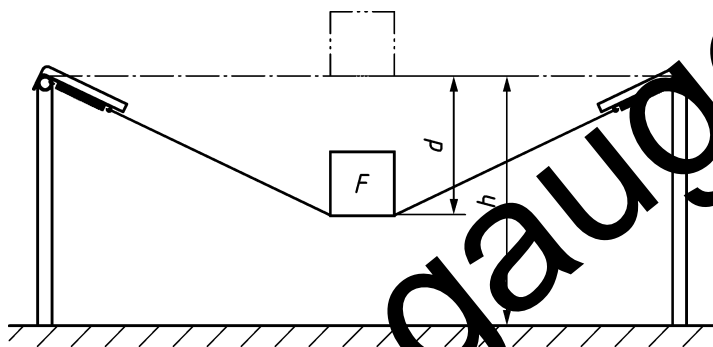

Key

- F test load
- d *mat* deflection
- h *mat* height

Figure 13 — Maximum deflection of the *mat*

Annex A (informative)

Rationale

A.1 Scope (see Clause 1)

Trampolines for domestic use often have properties similar to those classified as sports equipment. However, only trampolines intended for domestic use, regardless of size, are covered by the scope of this standard.

This standard does not cover the hazards associated with trampolines that are buried at ground level. The hazards associated with the use of such trampolines are different from those associated with the use of trampolines that are not buried, and have not been assessed and addressed.

The requirements in this standard take into account the presence of a parent or adult carer in charge of the surveillance of the user of the trampoline.

A.2 General (see 4.1 and 4.3.3)

Some of the requirements in EN 71-1 do not apply to trampolines for domestic use since the hazards addressed by these requirements are instead covered by detailed requirements in EN 71-14.

The scope of EN 71-8:2011 does not cover “toy trampolines”. However, for practical reasons certain requirements in this European standard refers to specific requirements in EN 71-8:2011 (e.g. regarding “entrapment” and “means of access”).

Clause 4 sets basic requirements intended to address, for example, the hazards associated with inadequate strength and children falling from *trampolines*. In addition, certain requirements for construction and assembly are specified.

The requirements in Clause 4 refer to different sizes of trampolines and the corresponding *maximum user weight*, since the risk for injury is related to the type of trampoline.

Accident data indicates that the main cause of injury is falling from the *mat* onto the ground (see also A.3). The second most common source of injury is poor quality and insufficient resistance of the connections in the *frame*. For this reason, Clause 4 sets requirements for both static and dynamic strength, as well as for *enclosures*.

A.3 Enclosures (see 4.3)

The requirement for a mandatory *enclosure* for medium and large trampolines is intended to address the hazard associated with falling off the trampoline during *bouncing*. The required minimum height of the *enclosure* is linked to the *frame* size of the trampoline since the potential *bouncing* height is related to the diameter of the *mat* and to the *maximum user weight*.

For mini trampolines, an *enclosure* is not mandatory due to the low potential *bouncing* height and/or the low potential fall height.

EN 71-1 specifies requirements for “Toys which a child can enter”. For such toys, EN 71-1 requires that, even if ventilation is ensured, it is possible for the child to escape easily from the confinement without help from the

outside. Also, for such toys having a door, lid or similar device, EN 71-1, requires that it shall be possible to open the toy from the inside. This requirement notably precludes the use of zips.

Since in the case of trampolines for domestic use, the main cause of injury is falling off the *mat*, it has been considered important to have a requirement for an *enclosure* with specified properties, on certain sizes of trampolines and to provide an easy handling of these by the use of a zip. Therefore, EN 71-14 exempts trampolines for domestic use from the EN 71-1 requirement in question.

In order to facilitate for a parent or adult carer to assist a child playing within the *enclosure*, it is specified that the opening of the *enclosure* can be used by an adult.

If a child enters the area under the *mat* there is a risk of the child being injured for example by the impact of another child *bouncing* on the *mat* or due to entrapment of the head between two springs. It is therefore important that a parent or adult carer can easily observe that no child is under the *mat*. For this reason, it is not permitted to enclose the area between the *mat* and the ground.

In order to specify a reproducible test set up the sandbag for the pendulum tests (see 6.1.2 and 6.3.2) has been defined in regards of its weight, filling and measures. The given formula allows the use of one and the same test set up by only varying the height from which the standard sandbag swings to the *enclosure*. Table A.1 shows some results of that formula as in 6.1.2 and 6.3.2 for common *maximum user weights* and also the energy which is equal to the energy if the sandbag would have the weight of the *maximum user weight* and h_2 would be fixed to 300 mm.

Table A.1 — h_2 dependence of the maximum user weight

User weight/mass of the pendulum (m_1) [kg]	h_1 [m]	Potential energy E_{pot} [J]	h_2^a [m]
75	0,300	221	0,188
80	0,300	235	0,200
85	0,300	250	0,212
95	0,300	280	0,238
100	0,300	294	0,250
105	0,300	309	0,262
110	0,300	324	0,275
115	0,300	339	0,288
120	0,300	353	0,300
125	0,300	368	0,313
130	0,300	383	0,325
135	0,300	397	0,337
140	0,300	412	0,350
145	0,300	427	0,363
150	0,300	442	0,375

^a Height required in order to achieve the same potential energy when fixing the mass of the sand bag to 120 kg (instead of using a height of 0,300 m (h_1) and a sand bag with a mass corresponding to the *maximum user weight*).

A.4 Durability of materials (see 4.4)

The standard specifies that the instructions for use shall include information highlighting that the consumer shall make regular checks and maintenance of the main parts of the trampoline. In addition, the standard addresses the hazards associated with deterioration of materials by specifying requirements for corrosion of certain metal parts, and light- and UV-stability of certain non-metal parts. These requirements are not intended to specify a certain lifetime of the products but aim at ensuring a basic level of durability.

The requirement regarding corrosion resistance refers to EN ISO 9227 and a 48 h test. This requirement is intended to provide a minimum level of protection against premature corrosion in average weather conditions.

The requirement regarding UV-stability refers to EN ISO 4892-3 and a 400 h cycle. The decision to define a 400 h test was a compromise solution based on lengthy discussions during which several other options were also discussed. When unambiguous data becomes available, showing a clear link between the duration of the test and the resistance of critical parts of a trampoline to UV exposure during practical use, the specified duration of the test will be revisited.

Due to the variations in climate between different parts of Europe, trampolines will be subject to different climatic conditions depending on where in Europe they are used. It is therefore recommended that manufacturers consider whether the durability requirements specified in this standard are sufficient to ensure the product remains functional after several seasons of use in the geographical area where the trampoline is expected to be sold.

A.5 Entrapment (see 4.5)

Trampolines like all other toys should be designed so as not to present a risk of entrapment to the user.

Fatal strangulation accidents are known to have occurred due to head entrapment. Therefore, openings are required to either be of a size that prevents the head from passing through, or of a size that allows the head and the torso to pass through.

The clause also includes requirements for *entrapment* of fingers as well as other parts of the body.

Injuries can occur when one or more fingers are trapped in holes, slots or gaps of rigid materials, while the remainder of the body is moving or continues in movement.

Dimensions have been decided taking into account available anthropometric data on little finger's breadth and length at the distal joint, and the age range considered appropriate for the use of the trampoline.

The accessibility of holes, slots or gaps should be assessed during use of the trampoline, considering the definition and test methods given in EN 71-1. In particular, holes inside larger holes should be considered as accessible if they can be reached by the accessibility probes.

In order to ensure the reproducibility of the test method on head and neck entrapment, in particular of elastic materials, a force of 222 N (adapted from EN 1176-1) for applying the probes has been specified.

A.6 Pinching and crushing hazards (see 4.6)

Most trampolines for domestic use are fitted with springs for the connection between the *mat* and the *frame*. In order to minimize the risk for pinching and crushing hazards, such springs are required to be protected.

A.7 Padding (see 4.9)

The *mat* is the intended surface for bouncing. However, accidents have occurred when children have unintentionally jumped, or fallen, on springs or the *frame*. It is therefore required that all such parts are protected with *padding* which contrasts with the *mat* and that has sufficient impact resistance. The requirements for the *padding* are based on requirements in EN 13219. In cases where the *enclosure* is fixed between the *mat* and the *padding*, it is obvious where the intended area for bouncing ends and therefore the requirement for contrasting colour or a border does not apply.

A.8 Strength test (see 4.10)

The requirements in 4.10.1 (vertical strength of the enclosure) base on the idea of foreseeable misuse of children by using the standard weight of 50 kg.

It is considered that the user of the trampoline will stand on the frame and the access device. The requirements in 4.10.2 (frame strength) and 4.10.5 (static strength of access device) cover such static loads with the coefficient of 1,5.

The intention of the requirement in 4.10.6 is to ensure that trampolines are designed in such a way that during bouncing no part of the mat can touch the frame or legs. When testing the strength of the *mat* it is necessary to consider both static and dynamic forces. For this reason a coefficient is used when calculating the mass to be used in the test of 4.10.6. During the elaboration of this standard, validating tests were made to ensure that this factor takes into account the average weight of the users and their rebound capacity. It was validated that a coefficient of 4 covers the dynamic effect. The coefficient also takes into account that an endurance testing is not part of the requirement.

It was taken into account that EN 13219 operates with higher coefficients which reflect the professional user ability to jump higher.

A.9 Mat deflection (see 4.11)

The intention of the requirement in 4.11 is to ensure that the distance of the mat to the ground or floor is sufficient in order to prevent the mat from contacting the ground or floor while the user is bouncing. Both static and dynamic forces are taken into account. For this reason a coefficient is used when calculating the mass to be used in the test of 4.11. During the elaboration of this standard, validating tests were made to ensure that this factor takes into account the average weight of the users and their rebound capacity. It was validated that a coefficient of 2,5 covers the dynamic effect of non professional users.

A.10 Warnings and markings on the product (see 5.2)

A common cause of injury is when trampolines are used by two or more users since the users can then collide. Therefore, a warning is required to clarify that only one user at the time should jump on the trampoline.

This standard considers trampolines for use by children with a *maximum user weight* specified by the manufacturer. Since different types of trampoline are intended for different age groups, and thereby *maximum user weights*, the manufacturer shall indicate the *maximum user weight* for the trampoline, respecting the limitations given in Table 1.

Annex ZA
(informative)

Relationship between this European Standard and the Essential Requirements of EU Directive 2009/48/EC on the safety of toys

This European Standard has been prepared under a mandate given to CEN by the European Commission and the European Free Trade Association to provide a means of conforming to Essential Requirements of the New Approach Directive 2009/48/EC on the safety of toys.

Once this standard is cited in the Official Journal of the European Union under that Directive and has been implemented as a national standard in at least one Member State, compliance with the clauses of this standard given in Table ZA.1 confers, within the limits of the scope of this standard, a presumption of conformity with the corresponding Essential Requirements of that Directive and associated EFTA regulations.

Table ZA.1 — Correspondence between this European Standard and Directive 2009/48/EC on the safety of toys

Clause(s)/subclause(s) of this EN	Essential Requirements (ERs) of Directive 2009/48/EC	Qualifying remarks/Notes
Clause 1; Clause 4; Clause 5	Article 10, 2 (General)	
Clause 5	Article 11 (General)	
4.3; 4.4; 4.10; 4.12	Annex II.I, 1 (Particular)	
4.7; 4.9	Annex II, I, 2 (Particular)	
4.6	Annex II, I, 3 (Particular)	
4.2; 4.3; 4.5; 4.8; 4.9; 4.11	Annex II, I, 11 (Particular)	
Clause 5	Annex V, Part A	
Clause 5	Annex V, Part B	

WARNING — Other requirements and other EU Directives may be applicable to the product(s) falling within the scope of this standard.

Bibliography

- [1] EN 1176-1, *Playground equipment and surfacing — Part 1: General safety requirements and test methods*
- [2] EN 15649 (all parts), *Floating leisure articles for use on and in the water*

www.china-gauges.com

www.china-gauges.com

British Standards Institution (BSI)

BSI is the national body responsible for preparing British Standards and other standards-related publications, information and services.

BSI is incorporated by Royal Charter. British Standards and other standardization products are published by BSI Standards Limited.

About us

We bring together business, industry, government, consumers, innovators and others to shape their combined experience and expertise into standards-based solutions.

The knowledge embodied in our standards has been carefully assembled in a dependable format and refined through our open consultation process. Organizations of all sizes and across all sectors choose standards to help them achieve their goals.

Information on standards

We can provide you with the knowledge that your organization needs to succeed. Find out more about British Standards by visiting our website at bsigroup.com/standards or contacting our Customer Services team or Knowledge Centre.

Buying standards

You can buy and download PDF versions of BSI publications, including British and adopted European and international standards, through our website at bsigroup.com/shop, where hard copies can also be purchased.

If you need international and foreign standards from other Standards Development Organizations, hard copies can be ordered from our Customer Services team.

Subscriptions

Our range of subscription services are designed to make using standards easier for you. For further information on our subscription products go to bsigroup.com/subscriptions.

With **British Standards Online (BSOL)** you'll have instant access to over 55,000 British and adopted European and international standards from your desktop. It's available 24/7 and is refreshed daily so you'll always be up to date.

You can keep in touch with standards developments and receive substantial discounts on the purchase price of standards, both in single copy and subscription format, by becoming a **BSI Subscribing Member**.

PLUS is an updating service exclusive to BSI Subscribing Members. You will automatically receive the latest hard copy of your standards when they're revised or replaced.

To find out more about becoming a BSI Subscribing Member and the benefits of membership, please visit bsigroup.com/shop.

With a **Multi-User Network Licence (MUNL)** you are able to host standards publications on your intranet. Licences can cover as few or as many users as you wish. With updates supplied as soon as they're available, you can be sure your documentation is current. For further information, email bsmusales@bsigroup.com.

BSI Group Headquarters

389 Chiswick High Road London W4 4AL UK

Revisions

Our British Standards and other publications are updated by amendment or revision.

We continually improve the quality of our products and services to benefit your business. If you find an inaccuracy or ambiguity within a British Standard or other BSI publication please inform the Knowledge Centre.

Copyright

All the data, software and documentation set out in all British Standards and other BSI publications are the property of and copyrighted by BSI, or some person or entity that owns copyright in the information used (such as the international standardization bodies) and has formally licensed such information to BSI for commercial publication and use. Except as permitted under the Copyright, Designs and Patents Act 1988 no extract may be reproduced, stored in a retrieval system or transmitted in any form or by any means – electronic, photocopying, recording or otherwise – without prior written permission from BSI. Details and advice can be obtained from the Copyright & Licensing Department.

Useful Contacts:

Customer Services

Tel: +44 845 086 9001

Email (orders): orders@bsigroup.com

Email (enquiries): cservices@bsigroup.com

Subscriptions

Tel: +44 845 086 9001

Email: subscriptions@bsigroup.com

Knowledge Centre

Tel: +44 20 8996 7004

Email: knowledgecentre@bsigroup.com

Copyright & Licensing

Tel: +44 20 8996 7070

Email: copyright@bsigroup.com