

# BRITISH STANDARD 546 : 1950

UDC 621.316.541

## TWO-POLE AND EARTHING-PIN PLUGS, SOCKET-OUTLETS AND SOCKET-OUTLET ADAPTORS



## FOR AC (50-60 Hz) CIRCUITS

## UP TO 250 V

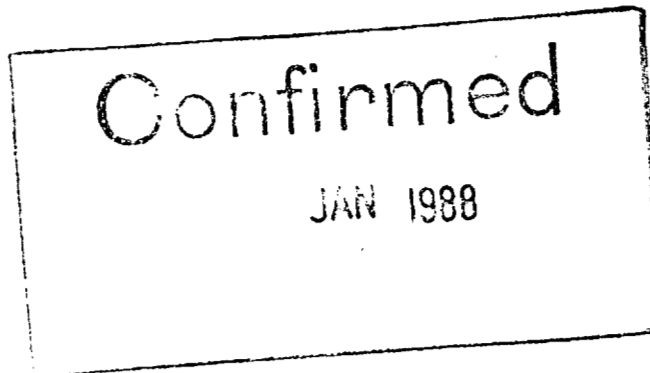

### BRITISH STANDARDS INSTITUTION

<http://www.china-gauges.com/>

# BRITISH STANDARD SPECIFICATION

## TWO-POLE AND EARTHING-PIN PLUGS, SOCKET-OUTLETS AND SOCKET-OUTLET ADAPTORS FOR AC (50-60 Hz) CIRCUITS UP TO 250 V B.S. 546 : 1950

Incorporating Amendments issued December, 1953 (PD 1752),  
November, 1961 (PD 4389), May, 1969 (AMD 251),  
Supplement No. 1 (1960) (PD 4007), July, 1977  
(AMD 2307) and August, 1982 (AMD 4045)

CONFIRMED NOVEMBER 1979

BRITISH STANDARDS INSTITUTION

Incorporated by Royal Charter

2 PARK STREET, LONDON, W1A 2BS

Telex: 266934

Telephone: 01-629 9000

<http://www.china-gauges.com/>

## B.S. 546 : 1950

THIS BRITISH STANDARD, having been approved by the Electrical Industry Standards Committee and endorsed by the chairman of the Engineering Divisional Council, was published under the authority of the General Council on 16th March, 1950.

The Institution desires to call attention to the fact that this British Standard does not purport to include all the necessary provisions of a contract.

In order to keep abreast of progress in the industries concerned, British Standards are subject to periodical review. Suggestions for improvements will be recorded and in due course brought to the notice of the committees charged with the revision of the standards to which they refer.

A complete list of British Standards, numbering over 9,000, fully indexed and with a note of the contents of each, will be found in the BSI Catalogue which may be purchased from BSI Sales Department. The Catalogue may be consulted in many public libraries and similar institutions.

Reference is made in this standard to the following British Standards :—

*As amended  
July, 1977*

B.S. 646 Ordinary-duty 250-volt cartridge fuses (rated up to 5 amperes) for A.C. and D.C. service.

B.S. 771 Phenolic moulding materials.

B.S. 1322 Aminoplastic moulding materials.

B.S. 1363 Fused-plugs and shuttered socket-outlets.

B.S. 2782 Method of testing plastics. Part 1. Effect of temperature.

*British Standards are revised, when necessary, by the issue either of amendment slips or of revised editions. It is important that users of British Standards should ascertain that they are in possession of the latest amendments or editions.*

ELE/4

## CO-OPERATING ORGANIZATIONS

The Electrical Industry Committee, under whose supervision this British Standard was prepared, consists of representatives from the following Government departments and scientific and industrial organizations :—

- \*Admiralty
- \*Air Ministry
- \*Association of Consulting Engineers, Incorporated
- \*Association of Supervising Electrical Engineers
- \*British Electrical and Allied Industries Research Association
- \*British Electrical and Allied Manufacturers' Association
- \*British Electrical Development Association
- British Railways
- \*British Electricity Authority
- Cable Makers' Association
- Electric Lamp Manufacturers' Association
- \*Electric Light Fittings Association
- \*Electrical Contractors Association (Incorporated)
- Electrical Contractors Association of Scotland
- Engineering Equipment Users Association
- \*General Post Office
- \*Institution of Electrical Engineers
- Ministry of Fuel and Power
- \*Ministry of Labour and National Service (Factory Department)
- \*Ministry of Supply
- \*Ministry of Works
- \*National Physical Laboratory
- North of Scotland Hydro-Electric Board
- Public Transport Association (Incorporated)
- Radio Industry Council

The Government departments and scientific and industrial organizations marked with an asterisk in the above list, together with the following, were directly represented on the Committee entrusted with the preparation of this British Standard :—

Crown Agents for the Colonies  
 Electrical Association for Women  
 Fire Offices Committee  
 Lloyd's Register of Shipping  
 National Register of Electrical Installation Contractors

B.S. 546 : 1950

BRITISH STANDARD SPECIFICATION FOR  
TWO-POLE AND EARTHING-PIN PLUGS,  
SOCKET-OUTLETS,  
AND SOCKET-OUTLET ADAPTORS  
FOR CIRCUITS UP TO 250 VOLTS

**FOREWORD**

The present revision of this British Standard is issued to incorporate modifications required in the light of modern practice. The testing requirements have been amplified to provide for better quality.

Five-ampere plugs and sockets are accepted in place of 10-ampere plugs and sockets in some countries abroad, provided that they comply, at the higher current-rating, with the relevant clauses of this standard. Such plugs and sockets are marked '10A.'

**SPECIFICATION**

**SECTION ONE. GENERAL**

**SCOPE**

1. This British Standard relates to plugs (fused and non-fused), socket-outlets (shuttered and non-shuttered), and fused socket-outlet adaptors (shuttered and non-shuttered).

**DEFINITIONS**

2. For the purpose of this standard the following definitions shall apply :—

*a. Plug.* A device carrying three metallic plug pins substantially cylindrical in form intended for engagement with corresponding socket contacts or adaptor contacts and arranged for connection to a 3-core flexible cord or cable.

*b. Fused-plug.* A plug with a fuse-link within it in circuit between the line plug pin and its terminal.

*c. Socket-outlet.* A device carrying three metallic socket contacts designed for engagement with corresponding plug pins or adaptor pins and arranged for connection to fixed wiring.

*d. Shuttered socket-outlet.* A socket-outlet having provision for screening its line and neutral socket contacts automatically with a shutter when they are not in engagement with corresponding plug pins or adaptor pins.

*e. Socket-outlet adaptor.* A device carrying three metallic adaptor pins substantially cylindrical in form (called the 'plug portion') intended for engagement with corresponding socket contacts, and also carrying one or more sets of adaptor contacts (called 'outlets') intended for engagement with corresponding plug pins. A fuse is fitted in the socket-outlet adaptor for each outlet of smaller current rating than that of the plug portion.

*f. Shuttered socket-outlet adaptor.* A socket-outlet adaptor having provision for screening each of its line and neutral adaptor contacts automatically with a shutter when they are not in engagement with corresponding plug pins.

NOTE. In this standard the term 'pin' shall be interpreted as meaning either a plug pin or an adaptor pin, and the term 'contact' meaning either a socket contact or an adaptor contact, according to the context.

*g. Type test.* A test of an article intended to show that all other articles made to the same design would, or would not, pass an identical test.

*h. Sampling test.* A test of a relatively small number of articles selected from a batch, intended to show that all other articles of the same batch would, or would not, pass an identical test.

*j. Pillar terminal.* A terminal in which the wire is put through a hole or slot in which it is secured by the end of a screw the axis of which is at an angle to the wire.

*As added  
Dec., 1953*

## SECTION TWO. GENERAL REQUIREMENTS

### APPLICATION

3.

Accessories shall be so designed and constructed that in normal use their performance is reliable and without danger to the user or to the surroundings. Accessories complying with this standard shall be capable of meeting all the relevant tests specified in this standard.

The gauges illustrated in Figures 2, 3, 4 and 5 shall be considered to comply with the dimensional requirements if the results of the measured values are within the specified dimensions and the uncertainty of measurement at not less than 95 % confidence level does not exceed  $\pm 0.0002 \text{ in}/0.005 \text{ mm}$ .

### POSITIONS OF SOCKET CONTACTS

4. When viewed from the front of a socket-outlet, the socket contacts shall have the relative positions shown in Fig. 1.

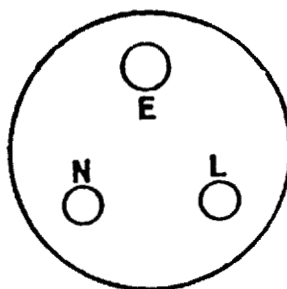

Fig. 1. Position of contacts

**INTERCHANGEABILITY**

5. Plugs, socket-outlets, and socket-outlet adaptors shall be tested for interchangeability in accordance with Clause 32.

**CURRENT RATING**

6. The current rating of non-fused plugs and of socket-outlets, and the nominal current rating of fused plugs (i.e. their current rating apart from the fuse), shall be either 2, 5, 15, or 30 amperes.

The actual current rating of a fused-plug as a whole being necessarily that of the fuse-link included in it, the current rating shall be expressed in terms both of the nominal current and of the current rating of the fuse-link, in the form of two numbers separated by a stroke ; for example. 15/5 shall be the current rating of a fused-plug of a nominal current rating of 15 amperes, including a 5-ampere fuse-link.

For current ratings of socket-outlet adaptors see Clause 29.

**PRECAUTIONS AGAINST ACCIDENTAL CONTACT**

7. Unless the external portions of the current-carrying parts of pins adjacent to a plug base or a socket-outlet adaptor base are insulated with sleeves of the minimum length given in Table 1, no part of them shall be less than the minimum distance given in Table 1 from the periphery of the plug base or of the socket-outlet adaptor base.

**TABLE 1. LENGTHS AND DISTANCES**

Current rating	Minimum length	Minimum distance
amp.	in.	in.
2	0.187	0.250
5	0.250	0.312
15	0.312	0.375
30	0.375	0.500



Plugs, socket-outlets, and socket-outlet adaptors shall be so constructed as to :—

a. prevent an earthing-pin from making contact with a current-carrying contact in any circumstances,

b. prevent a current-carrying pin from making contact with a current-carrying contact while either or both of the other pins are completely exposed, and

c. ensure that when a plug is withdrawn from a shuttered socket-outlet the current-carrying socket contacts are automatically screened by shutters not operated solely by the insertion of one current-carrying pin.

Such shutters shall be deemed to constitute compliance with Sub-clause b.

*As added  
Dec., 1953*

The current-carrying contacts shall be sunk below the surface of the socket-outlet or socket-outlet adaptor so as to ensure compliance with Clause 8, and in such a way as to make it impossible for them to be touched unintentionally.

**ENGAGEMENT OF PINS AND CONTACTS**

8. On insertion of pins into contacts the travel from the first point of contact of current-carrying parts to complete engagement shall be not less than the minimum, or more than the maximum, given in Table 2, and there shall be electrical connection between pins and contacts throughout the travel.

**TABLE 2. CONTACT TRAVEL**

Current rating	Minimum	Maximum
amp.	in.	in.
2	0.141	0.223
5	0.164	0.246
15	0.187	0.269
30	0.328	0.422

*As amended  
July, 1977*

An earthing pin shall make and break contact with the corresponding earthing contact respectively before and after the associated current-carrying pins make and break contact with the corresponding current-carrying contacts.

There shall be no projections on the face of a plug base, or on the face of a socket-outlet, such as would prevent complete engagement between pins and contacts, within a circle having the radius given in Table 3 and concentric with the circle through the centres of the pins and the centres of the contacts.

B.S. 546 : 1950

TABLE 3. RADIUS OF ENGAGEMENT CIRCLE

Current rating	Radius
amp.	in.
2	0.76
5	1.07
15	1.27
30	1.65

## SPACING OF PINS AND CONTACTS

9. The nominal distance between centres of pins shall be as given in Table 4. The spacing of contacts shall correspond to that of pins.

TABLE 4. PIN SPACING

Current rating	Nominal distance between centres of current-carrying pins	Nominal distance between centres of each current-carrying pin and the earthing pin
amp.	in.	in.
2	0.570	0.570
5	0.750	0.875
15	1.000	1.125
30	1.437	1.562

## EARTHING OF EXPOSED METAL PARTS

10. Any metal parts of a plug, or of a socket-outlet adaptor, that may be exposed when the plug or the socket-outlet adaptor is in complete engagement with a socket-outlet shall be in effective electrical connection with the earthing pin.

All exposed metal parts of a socket-outlet shall be in effective electrical connection with the earthing contact except that metal parts on, or screws in or through, non-conducting material, and separated by such material from current-carrying parts in such a way that in normal usage they cannot become live, need not be in effective electrical connection with the earthing contact.

CLEARANCE AND CREEPAGE

11. The minimum clearance distance in air, and the minimum creepage distance, shall be 0.1 in.



**12. Materials**

**12.1** All materials shall comply with the requirements given in **12.2** to **12.8**, where relevant.

**12.2** Parts made of insulating material which might be exposed to thermal stresses due to electric effects, and deterioration of which might impair the safety of the accessory, shall not be unduly affected by abnormal heat and fire.

Except for parts made of ceramic material and small components such as washers, compliance shall be checked by the test described in **12.4**.

**12.3** Current-carrying parts shall be made of brass, copper, phosphor-bronze or other material at least equivalent with regard to its conductivity, resistance to abrasion and resistance to corrosion.

Compliance shall be checked by the tests described in **12.6**, **33** and **39**.

**12.4** The glow-wire test shall be performed in accordance with clauses **4** to **10** of BS 6458 : Section 2.1 : 1984, and at the test temperature given in Table 5.

**TABLE 5. APPLICATION OF GLOW-WIRE TEST**

Part	Glow-wire temperature	
	Portable accessories	Fixed accessories
	°C	°C
Parts necessary to retain current carrying parts in position	750 ± 10	850 ± 15
Parts not necessary to retain current carrying parts in position (although they may be in contact with them)	650 ± 10	650 ± 10

NOTE 1. If the test specified is required to be made at more than one place on the same specimen, it is essential that care is taken to ensure that any deterioration caused by previous tests does not affect the result of the test to be made.

NOTE 2. Small parts unlikely to be subjected to abnormal heat and the failure of which to pass these tests would not materially affect the safety of the accessory are not subjected to this glow-wire test.

The glow-wire test shall be applied to ensure that an electrically heated test wire under defined test conditions does not cause ignition of insulating parts or to ensure that a part of insulating material, which might be ignited by the heated test wire under defined conditions, has a limited time to burn without spreading fire by flame or burning parts or droplets falling down from the tested part onto a pinewood board covered with tissue paper.

The test specimen shall be either:

- a) a complete accessory; or,
- b) if the test cannot be made on a complete accessory, a suitable part may be cut from one for the purpose of the test.

The test shall be made on one specimen. In case of doubt, the test shall be repeated on two further specimens.

The test shall be made applying the glow wire once.

The specimen shall be positioned during the test in the most unfavourable position of its intended use (with the surface tested in a vertical position). The tip of the glow-wire shall be applied to the specified surface of the specimen, taking into account the conditions of the intended use under which a heated or glowing element may come into contact with the specimen.



The specimen shall be regarded as having passed the glow-wire test if:

- 1) there is no visible flame and no sustained glowing; or
- 2) flames and glowing at the specimen extinguish within 30 s after the removal of the glow-wire.

There shall be no ignition of the tissue paper nor scorching of the board.

**12.5** Current carrying parts of copper alloy containing less than 80% of copper, and which are press formed or produced in a manner which could induce excessive internal stresses, shall be resistant to failure in use due to brittleness, when tested in accordance with **12.6**.

**Warning.** Refer to the supplier's health and safety data sheets for the precautions which are to be taken for the safe use of mercurous nitrate, nitric acid, ammonium chloride, alkalis and organic solvents.

NOTE. Attention is drawn to the Control of Substances Hazardous to Health (COSHH) Regulations 1988 [1].

**12.6** The test specimen shall be degreased in a suitable alkaline degreasing solution or organic solvent, then immersed in an aqueous solution of mercurous nitrate containing 10g of  $\text{Hg}_2(\text{NO}_3)_2$  and 10 ml of  $\text{HNO}_3$  (relative density 1.42) per l of solution for  $(30 \pm 1)$  min at a temperature of  $(20 \pm 5)$  °C.

After the treatment, the test specimen shall be washed in running water, and any excess mercury shall be wiped off.

The sample shall immediately be examined visually.

There shall be no cracks visible with normal or corrected vision without additional magnification.

**12.7** Ferrous parts shall be adequately protected against rusting. Compliance is checked by the test of **12.8**.

**12.8** The test specimens shall be degreased in a suitable alkaline degreasing solution or organic solvent.

The specimens shall then be immersed for  $(10 \pm 0.5)$  min in a 10% solution of ammonium chloride in water, at a temperature of  $(20 \pm 5)$  °C.

Without drying, but after shaking off any drops, the specimens shall be placed for  $(10 \pm 0.5)$  min in a box containing air saturated with moisture, at a temperature of  $(20 \pm 5)$  °C.

The specimens shall be dried for at least 10 min in a heating cabinet at a temperature  $(100 \pm 5)$  °C.

NOTE 1. Traces of rust on sharp edges, and any yellowish film removable by rubbing are ignored.

NOTE 2. For small helical springs and the like, and for parts exposed to abrasion, a layer of grease may provide sufficient protection against rusting. Such parts are only subjected to test if there is doubt about the effectiveness of the grease film, and the test should then be made without previous removal of the grease.

TABLE 7. DIMENSIONS OF PLUG PINS

Current rating	Plug pins	Diameter	Length of radiused end portion	Total projection from plug base
amp.		in.	in.	in.
2	Current-carrying	0.140	0.046	0.500
		0.200	0.062	0.625
5	Current-carrying	0.200	0.062	0.585
		0.278	0.078	0.812
15	Current-carrying	0.278	0.078	0.733
		0.343	0.093	1.125
30	Current-carrying	0.312	0.093	1.125
		0.375	0.109	1.437
		Tolerance on all diameters ±0.001 in.	Tolerance on all lengths } in. +0.01 -0	Tolerance on projections 2 and 30 amp. rating } in. +0.041 -0.005 5 and 15 amp. rating } in. +0.030 -0.005

*As amended July, 1977*

*As amended July, 1977*



The plug pins shall be solid, split, or slotted axially with a single slot. If they are slotted the dimensions of the slots shall be as given in Table 8.

TABLE 8. DIMENSIONS OF SLOTS IN PLUG PINS

Current rating	Plug pins	Nominal width of slot	Minimum length of slot
amp.		in.	in.
2	Current-carrying	0.018	0.250
		0.023	0.300
5	Current-carrying	0.023	0.300
		0.032	0.420
15	Current-carrying	0.032	0.420
		0.032	0.670
30	Current-carrying	0.032	0.670
		0.032	1.000

**B.S. 546 : 1950**

The construction of a split plug pin or of a slotted plug pin shall be such as to prevent it from closing to less than its specified diameter. The means of ensuring this shall be an integral part of the plug pin.

**CONSTRUCTION OF PLUG PINS AND TERMINALS**

16. Each plug pin of a non-fused plug, each earthing plug pin, and each neutral plug pin of a fused-plug, shall be formed in one piece with the fixed part of its terminal.

Each terminal shall be of substantial construction, and the terminals of a non-fused plug, and the earthing terminal and the neutral terminal of a fused-plug, shall each provide for clamping and securing its flexible conductor so that efficient electrical connection is made direct with an integral part of the plug pin. The connection of the flexible conductor to the earthing plug pin may be visible when the cover of the plug is in position.



That contact for the fuse-link which is connected to the line terminal of a fused-plug shall be formed in one piece with the fixed part of the terminal or connected to it in such a way that it cannot work loose under normal service conditions, and the other contact shall be similarly connected to the corresponding plug pin. The line terminal shall also provide for clamping and securing the conductor so that efficient electrical connection is made with the contact for the fuse-link.

If the plug pins are removable from the plug base the pins and/or the plug base shall be so designed that it is impossible to assemble them in such a way that the fuse is connected to the neutral terminal.



When pillar terminals are used they shall either:

a) meet the requirements given in Table 9, and have cheese-headed clamping screws long enough under the head to extend to the far side of the conductor holes and with slightly rounded ends to minimize damage to conductors; or

b) meet the requirements given in Table 9a. Terminal screws used in making electrical connections shall have a root area not less than that of the appropriate screws in Table 9a and shall withstand the minimum torques given in Table 9a. If ISO metric screws are used, they shall comply with BS 3643.

**TABLE 9a. PLUG TERMINAL SCREWS: SIZE AND TORQUE**

Current rating of plug	Minimum thickness of the wall where the clamping screw passes through	Minimum nominal diameter	Minimum torque rating
amp.	mm	mm	Nm
2	1.4	2.5	0.4
5	1.6	3	0.5
15	3.2	3.5	0.8
30	4.8	4	1.2

The sizes of the conductor hole and the clamping screw shall be such that the clearance between the sides of the major diameter of the clamping screw and the conductor hole does not exceed 0.4 mm.'



SEPARATION OF TERMINALS AND CONDUCTORS

17. Insulating barriers forming an integral part of the plug shall be provided so as to separate metal at different potentials, including bared flexible conductors. The barriers shall be such that when the plug has been correctly wired and assembled there is negligible risk that a wire or strand that may become loose shall touch other parts with which contact may be dangerous.

*As altered  
Dec., 1953*

METHOD OF ENTRY OF FLEXIBLE CORD OR CABLE

18. The flexible cord or cable shall enter the plug through one hole, groove, or gland, and there shall be provision for gripping and protecting, at the point of entry, a 3-core circular flexible cord or cable as given in Table 10 together with its protective covering or sheath, to prevent stress on the connections with the terminals.

TABLE 10

OVERALL DIAMETERS OF FLEXIBLE CORDS AND CABLES

Current rating of corresponding socket-outlet	For non-fused plugs	For fused-plugs
amp.	in.	in.
2	0.205 to 0.340	0.205 to 0.340
5	0.250 to 0.370	0.205 to 0.370
15	0.315 to 0.460	0.205 to 0.370
30	0.360 to 0.580	—

The flexible cord or cable shall enter at the side opposite to the earthing plug pin and between the current-carrying plug pins.

FINGER GRIP

19. A finger grip or other suitable means shall be provided for inserting and withdrawing the plug without subjecting the flexible cord or cable to any stress, and such grip shall be so designed as to discourage gripping the plug by the fingers at the point of entry of the flexible cord or cable.

SECTION FOUR.

SPECIAL REQUIREMENTS FOR SOCKET-OUTLETS

SOCKET CONTACTS

20. The socket contacts shall be so shaped at the point of entry as to provide easy access for appropriate plug pins. They shall be self-adjusting

**B.S. 546 : 1950**

as to contact making, and shall also be self-adjusting as to pitch at least up to the limits permitting them to accept the gauges specified in Clause 41, and each socket contact shall be such as to make and maintain, under normal service conditions, effective electrical and mechanical contact with a corresponding plug pin having the maximum diameter, and also with a corresponding plug pin having the minimum diameter, specified in Clause 15. The means for producing the contact pressure shall be associated with each socket contact independently.

Unless there is a shutter intended to prevent current-carrying socket contacts from being touched, the diameter of the holes in the socket-outlet plate or cover for the reception of current-carrying plug pins shall be not greater than that shown in Table 11.

**TABLE 11. SOCKET CONTACT HOLES**

<b>Current rating</b>	<b>Maximum diameter</b>
amp.	in.
2	0.165
5	0.225
15	0.303
30	0.337

**CONSTRUCTION OF SOCKET CONTACTS AND TERMINALS**

**21.** Each socket contact shall be provided with a terminal, which shall be of substantial construction and shall be connected to its socket contact in such a way that it cannot work loose under normal service conditions.

Each terminal shall provide adequate means of clamping firmly a maximum of two appropriate conductors, except that terminals of 30-ampere socket contacts shall provide for clamping firmly only one conductor.



When pillar terminals are used they shall either:

a) meet the requirements given in Table 12, and have cheese-headed clamping screws long enough under the head to extend to the far side of the conductor holes and with slightly rounded ends to minimize damage to conductors; or

b) meet the requirements given in Table 12a. Terminal screws shall have the minimum root areas and shall withstand the minimum torques given in Table 12a. If ISO metric screws are used, they shall comply with BS 3643.

**TABLE 12a. SOCKET-OUTLET TERMINAL SCREWS: SIZE AND TORQUE**

Current rating of socket-outlet	Minimum nominal diameter and minimum torque rating of ISO metric screws							
	Single screw with head		Two screws with head		Single screw without head		Two screws without head	
	Size	Torque	Size	Torque	Size	Torque	Size	Torque
A	mm	Nm	mm	Nm	mm	Nm	mm	Nm
2	2.5	0.4	-	-	2.5	0.2	-	-
5	3	0.5	2.5	0.4	3	0.25	2.5	0.2
15	3.5	0.8	2.5	0.4	3.5	0.4	2.5	0.2
30	4	1.2	3	0.5	4	0.7	3	0.25

The sizes of the conductor hole and the clamping screw shall be such that the clearance between the sides of the major diameter of the clamping screw and the conductor hole does not exceed 0.6 mm.

**TABLE 12. DIMENSIONS OF PILLAR TERMINALS**

Current rating	Nominal diameter of hole for conductor	Minimum thickness of wall where clamping screw passes through	Size of clamping screw
amp.	in.	in.	B.A. thread
2	0.125	0.062	No. 6
5	0.140	0.062	No. 5
15	0.172	0.125	No. 4
30	0.250	0.187	No. 2

**SEPARATION OF TERMINALS AND CONDUCTORS**

22. Insulating barriers securely fixed into, or forming an integral part of, the socket-outlet shall be provided to separate metal at different potentials within the socket-outlet.

**FIXING-HOLES**

23. The fixing-holes in the socket-outlet shall be suitable for wood screws of the sizes given in Table 13.

**TABLE 13. WOOD SCREW SIZES**

Current rating	Size of wood screws
amp.	
2	No. 5
5	No. 6
15	No. 6
30	No. 8

**POSITION OF FIXING-HOLES**

B.S. 546 : 1950



**Clause 25 - Deleted**

**Table 14 - Deleted**

**Table 15 - Deleted**

**PLATE FOR FLUSH-TYPE SOCKET-OUTLET**

**26. A socket-outlet plate shall be provided for flush-type socket-outlets with means for preventing it from turning relatively to an associated socket-outlet base, but to allow for any required adjustment of the socket-**

outlet plate if a socket-outlet box is fitted out of square provision may be made for a relative rotational angular movement of  $5^\circ$  on each side of the symmetrical position between a socket-outlet box and the associated socket-outlet.

## SECTION FIVE.

### SPECIAL REQUIREMENTS FOR SOCKET-OUTLET ADAPTORS

#### GENERAL

27. Socket-outlet adaptors, in addition to complying with the relevant clauses of this standard in features of plugs and socket-outlets common to socket-outlet adaptors, shall comply with the clauses in this section.

#### FUSE-LINKS

28. Provision shall be made within the body of a socket-outlet adaptor for Type A fuse-links to B.S. 646.\* (These shall be rated at not more than 2 amperes in 2-ampere outlets.) The fuse-links shall be mounted in appropriate fixed contacts between the line pin and the line contacts of outlets in accordance with Table 16, and in such a way that they cannot become displaced when the socket-outlet adaptor is in use.

Means shall be provided to protect the hand against damage from the blowing of a fuse-link during the insertion of a socket-outlet adaptor into, or its withdrawal from, a socket-outlet, or during the insertion of a plug into, or its withdrawal from, an outlet; and the socket-outlet adaptor as a whole shall be strong enough not to fracture should the fuse-link burst on blowing in service.

It shall be impossible to replace a fuse-link in a socket-outlet adaptor unless the socket-outlet adaptor is completely withdrawn from the socket-outlet.

#### CURRENT RATING OF PINS AND CONTACTS

29. The current rating of a plug portion shall be the same as the current rating of the socket-outlet with which it is to be used, and shall be either 5 amperes or 15 amperes.

The number and the current ratings of outlets shall be as shown in Table 16.

- The maximum rating of Type A fuse-links to B.S. 646 is 5 amperes.

## SECTION SIX. MARKING

8

## MARKING

'Plugs and socket-outlets and socket-outlet adaptors shall be legibly and durably marked with the following information which shall not be placed on screws, removable washers or other removable parts, or on parts intended for separate sale.

The name or trade mark of the manufacturer or responsible vendor.

The number of this British Standard, i.e. BS 546\*.

In addition, they shall be marked with the following.'

At the foot of the page, insert the following footnote.

\*Marking BS 546 : 1950 on or in relation to a product represents a manufacturer's declaration of conformity, i.e. a claim by or on behalf of the manufacturer that the product meets the requirements of the standard. The accuracy of the claim is solely the claimant's responsibility. Such a declaration is not to be confused with third-party certification of conformity.'

In the list headed 'Plugs', delete item *a.* entirely and substitute the following.

'*a.* The terminals for the connection of line and neutral conductors shall be identified by their respective symbols L and N. The symbol used for the protective terminal shall be either  $\oplus$  (which is preferred) or  $\frac{\perp}{\equiv}$  which may be accompanied by the letter E.'

In the list headed 'Socket-outlets', delete items *a.* and *b.* and substitute the following.

'*a.* The rated current in amperes.

*b.* The rated voltage, i.e. 250 volts.

*c.* Nature of supply, i.e. ~ (preferred) or a.c.

*d.* The terminals for the connection of line and neutral conductors shall be identified by their respective symbols L and N. The symbol used for the protective terminal shall be either  $\oplus$  (which is preferred) or  $\frac{\perp}{\equiv}$  which may be accompanied by the letter E.

NOTE. For the marking of the rated current and rated voltage of the socket outlet, figures may be used alone, the figures for the current rating being placed before or above that of the rated voltage and separated by a line.

If a symbol for nature of supply is used, it shall be placed next to the marking for rated current and rated voltage. Examples are as follows:

15A 250V a.c. or 15/250 ~ or  $\frac{15}{250}$  ~'

*Plugs.*

- a.* The letters L and N and the symbol  $\frac{\perp}{\equiv}$  and, if practicable, should be accompanied by the letter E.
- b.* Fused plugs. The word FUSED so that it is visible when the plug is in engagement with a socket-outlet.
- c.* Fused plugs. The words USE CORRECT FUSE-LINKS, or words to this effect.

*Socket-outlets.*

- a.* Current rating.
- b.* The letters E, L, and N, to indicate the terminals corresponding respectively to the earthing socket contact (E), the line socket contact (L), and the neutral socket contact (N). The letters shall be as close as practicable to the corresponding terminals.

As altered  
May, 1969

*Socket-outlet adaptors.*

- a. Current rating of the plug portion.
- b. The word FUSED.
- c. The words USE CORRECT FUSE-LINKS, or similar words.
- d. The words TOTAL LOADING MUST NOT EXCEED \*.....AMPERES, or words to this effect.

## SECTION SEVEN. SAMPLING TESTS

## GENERAL

31. The tests specified in Clauses 32 to 36 shall be sampling tests. The plugs and socket-outlets and socket-outlet adaptors used for the tests shall be in clean, new condition at the commencement of the tests, and shall be identical in all essential details with those to be used in service.

## INTERCHANGEABILITY

32. Plugs, socket-outlets, and socket-outlet adaptors shall be tested for interchangeability by means of the gauges specified in Clause 41, and compliance with the gauges shall be deemed to prove accuracy in respect of the relevant dimensions.

## EFFECTIVENESS OF CONTACT

33. The minimum withdrawal-pull of a gauge  
 (a) from an individual socket contact in a complete socket-outlet, and  
 (b) from an individual adaptor contact in a complete socket-outlet adaptor, shall be as shown in Table 17. As an alternative to (a), the maximum voltage-drop between an individual current carrying socket contact in a complete socket-outlet and a corresponding plug pin, measured between the terminal of the socket contact and the terminal of the plug pin, shall be 25 millivolts at the current rating.

*Is amended  
Aug. 1982*

The effectiveness of contact for metal components connected to an earth terminal of a socket-outlet shall be checked by the following test.

A current of  $(25 \pm 0.75)$  A, derived from an a.c. source, having a no-load voltage not exceeding 12 V, is passed for  $60 \begin{smallmatrix} +5 \\ 0 \end{smallmatrix}$  s and between the earthing terminal and a plug pin inserted in the earthing socket contact.

The resistance between the terminal and any other part shall not exceed 0.05  $\Omega$ .



B.S. 546 : 1950

**TABLE 17**  
**WITHDRAWAL-PULL (MINIMUM) FOR EFFECTIVENESS**  
**OF CONTACT**

Current rating	Minimum withdrawal-pull
amp.	oz.
2	8
5	8
15	12
30	24

During a withdrawal-pull test made in accordance with this clause, the socket-outlet and the socket-outlet adaptor shall be so held that the gauge is substantially vertical and the projecting part of it is downmost.

#### WITHDRAWAL-PULL

34. The maximum withdrawal-pull of a plug from a socket-outlet shall be as shown in Table 18.

**TABLE 18**  
**WITHDRAWAL-PULL (MAXIMUM) OF COMPLETE PLUG**

Current rating	Maximum withdrawal-pull
amp.	lb.
2	8
5	14
15	18
30	24

#### INSULATION RESISTANCE

35. Each plug and socket-outlet and each socket-outlet adaptor tested shall pass an insulation resistance test before being subjected to a high-voltage test as required by Clause 36. The insulation resistance shall be

not less than 100 megohms, and the test shall be made at approximately 500 volts D.C. applied for a sufficient time for the reading of the measuring instrument to become steady, the voltage being obtained from an independent source or generated in the measuring instrument. The insulation resistance shall be measured (a) between line and neutral, and (b) between line and neutral connected together and any other parts insulated therefrom, including earthing terminals.

#### HIGH-VOLTAGE TEST

36. Each plug and socket-outlet and each socket-outlet adaptor tested shall pass a momentary high-voltage test, for which the test voltage shall be 1500 volts (r.m.s.) alternating, approximately of sine-wave form, at a frequency of approximately 50 cycles per second, and shall be applied (a) between line and neutral, and (b) between line and neutral connected together and any other parts insulated therefrom, including earthing terminals.

### SECTION EIGHT. TYPE TESTS

#### GENERAL

37. The tests specified in Clauses 38 to 40 shall be type tests. The plugs and socket-outlets and socket-outlet adaptors used for the tests shall be in clean, new condition at the commencement of the tests, and shall be identical in all essential details with those to be used in service.

The purchaser shall accept certificates of type tests as evidence of compliance with the requirements of this standard, and the manufacturer shall hold available such certificates, together with detail drawings and a record of any alterations that have been made subsequent to the type tests. Type tests shall be made by the manufacturer, but he shall arrange for a recognized authority to make any type tests for which he himself is not equipped.

#### CURRENT-BREAKING

The breaking capacity of socket contacts shall be adequate.

Socket-outlets or adaptors shall be connected and mounted as in normal use.

The socket contacts shall be capable of making and breaking a current 30% in excess of their current rating, when tested in a substantially non-inductive a.c. circuit at  $275\text{ V} \pm 5\text{ V}$ . The plug and socket-outlet shall break the circuit 10 times in succession at intervals of approximately 30 seconds, a plug of the corresponding rating being withdrawn from the socket-outlet at a speed of approximately 150 mm per second immediately after insertion.

NOTE. For the purpose of this test, the fuse link, if any, may be replaced by a link of negligible impedance.

After the test, the socket-outlet shall be capable of satisfying the subsequent tests detailed in clauses 33 and 39.



#### TEMPERATURE-RISE OF FUSED-PLUGS AND SOCKET-OUTLET ADAPTORS

39. Fused-plugs shall be tested in socket-outlets for temperature-rise at their current rating.

Socket-outlet adaptors shall be fitted into socket-outlets and equipped with non-fused plugs for temperature-rise tests. The fused outlets shall be loaded to their full rated capacity, and the non-fused outlet, if any, shall carry the difference between the sum of the currents carried by the fused outlets and the current rating of the plug portion.

The temperature-rise of any terminal to which flexible cord is to be attached, and of the pins of socket-outlet adaptors, shall not exceed 35°C. (63°F.) after sufficient time has elapsed for the temperature to become steady. The fuse-links used in this test shall have a dissipation of not less than 0.27 watt for 2-ampere fuse-links or 0.45 watt for 5-ampere fuse-links, and not more than 0.3 watt for 2-ampere fuse-links or 0.5 watt for 5-ampere fuse-links.

The temperature-rise shall be measured by thermocouples attached by low-melting-point alloy or by some equally effective means of attachment.

NOTE. Base-metal thermocouples, attached by low-melting-point alloy of equal parts of lead, tin, and bismuth, are suitable.

#### SHUTTERS

40. Shutters shall be capable of continuing to work after having been operated mechanically 5000 times by the pins of corresponding plugs not carrying any current, at a rate not exceeding 20 complete cycles per minute, and at regular intervals. The means used for moving the pins shall be such as to give a speed of approximately 6 inches per second both during insertion and during withdrawal.

#### SECTION NINE. GAUGES

40a. The gauges illustrated in figures 2, 3, 4 and 5 shall be considered to comply with the dimensional requirements if the results of the measured values are within the specified dimensions and the uncertainty of measurement at not less than 95 % confidence level does not exceed  $\pm 0.0002$  in 0.005 mm.

41. 'Go' gauge for plug (see Fig. 3 and Table 20). The gauge is to prove correct spacing of plug-pins. It accepts the plugs with plug-pins at any centres that can be accepted without interference in socket-outlets gauged by the maximum and minimum socket-gauges.

In addition it proves the absence of axial projections on the face of the plug-base when a plug is fully inserted into the gauge, and it also indicates accuracy of projection of the plug-pins from the face of the plug if the end of each plug-pin lies within the appropriate step on the back of the gauge when the plug is fully inserted.

NOTE. Correctness of the diameter of individual plug-pins in accordance with Clause 15, Table 7 must be assured before this gauge is used.

*'Go' gauges for socket-outlet* (see Figs. 4 and 5 and Tables 21 and 22). Two gauges are required, each having pins of the maximum diameters specified in Clause 15, but one gauge having its pins so set that its complete insertion into a socket-outlet proves that the socket-outlet will accept, without interference, a plug having plug-pins at the maximum centre distance and the other gauge having its pins so set that its complete insertion into a socket-outlet proves that the socket-outlet will accept without interference a plug having plug-pins at the minimum centre distance. The socket-outlet gauges also prove the absence of axial projections on the face of the socket-outlet.

*Withdrawal-pull gauges for effectiveness of contact* (see Fig. 2). These gauges are to test the withdrawal-pull specified in Clause 33, and shall be used in individual socket-contacts of complete socket-outlets. They shall be applied, when used, after the maximum 'GO' gauge for socket-outlet. When gauging line and neutral socket-contacts, the shutter, if any, shall be kept clear of the gauge.

B.S. 546 : 1950

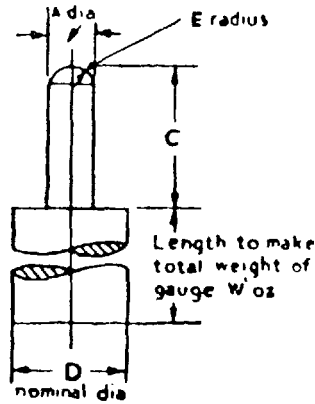

Fig. 2. Withdrawal-pull gauge for effectiveness of contact (see Clause 33)\*

TABLE 19. WITHDRAWAL-PULL GAUGES

Current rating	Contacts	A	C	D	W	E
amp.		in.	in.	in.	oz.	in.
2	Current-carrying	0.139	0.500	0.625	8	0.074
	Earthing	0.199	0.625	0.625	8	0.108
5	Current-carrying	0.199	0.585	0.625	8	0.108
	Earthing*	0.277	0.812	0.750	8	0.158
15	Current-carrying	0.277	0.733	0.750	12	0.158
	Earthing	0.342	1.125	0.875	12	0.199
30	Current-carrying	0.311	1.125	1.000	24	0.173
	Earthing	0.374	1.437	1.000	24	0.211
Tolerance		+0.000 0 -0.000 3	±0.001		+1 dram -0 dram	±0.005

As amended  
July, 1977

\* A 5-ampere earthing-contact gauge may, if desired, be adapted to accommodate additional weight for gauging 15-ampere current-carrying contacts.

NOTE. The radiused end of the gauge is to be part of a sphere.

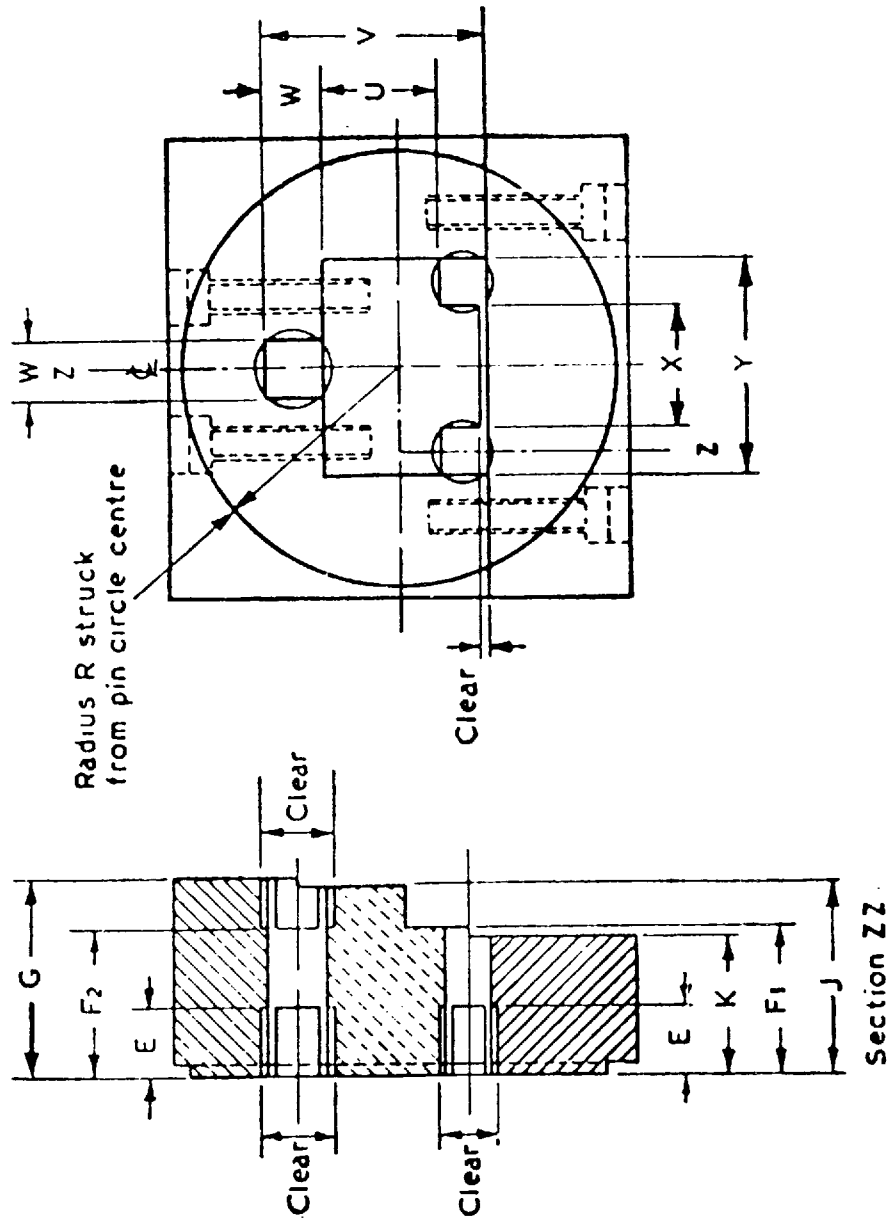

Fig. 3. 'GO' gauge for plug

As amended  
July 1977

TABLE 20. 'GO' GAUGE FOR PLUG

Rating	U	V	W	X	Y	E	F1	G	J	K	R	F2
amps.	in.	in.	in.	in.	in.	in.	in.	in.	in.	in.	in.	in.
2	0.3166	0.6706	0.2070	0.4230	0.7170	0.25	0.5410	0.6660	0.6200	0.4950	0.76	0.54
5	0.5446	1.0366	0.2850	0.5430	0.9570	0.30	0.6150	0.8530	0.8070	0.5800	1.07	0.67
15	0.6903	1.3253	0.3500	0.7150	1.2850	0.40	0.7630	1.1660	1.1200	0.7280	1.27	0.85
30	1.0369	1.7379	0.3820	1.1180	1.7560	0.50	1.1660	1.4780	1.4320	1.1200	1.65	1.17
Tolerance	+0.0003	+0.0000	+0.0000	+0.0003	+0.0000	+0.01	+0.0005	+0.0005	+0.0000	+0.0000		+0.01
	-0.0000	-0.0003	-0.0003	-0.0003	-0.0003	-0.01	-0.0000	-0.0000	-0.0005	-0.0005		-0.01

NOTE. The drawings are not intended to be mandatory regarding details of construction.

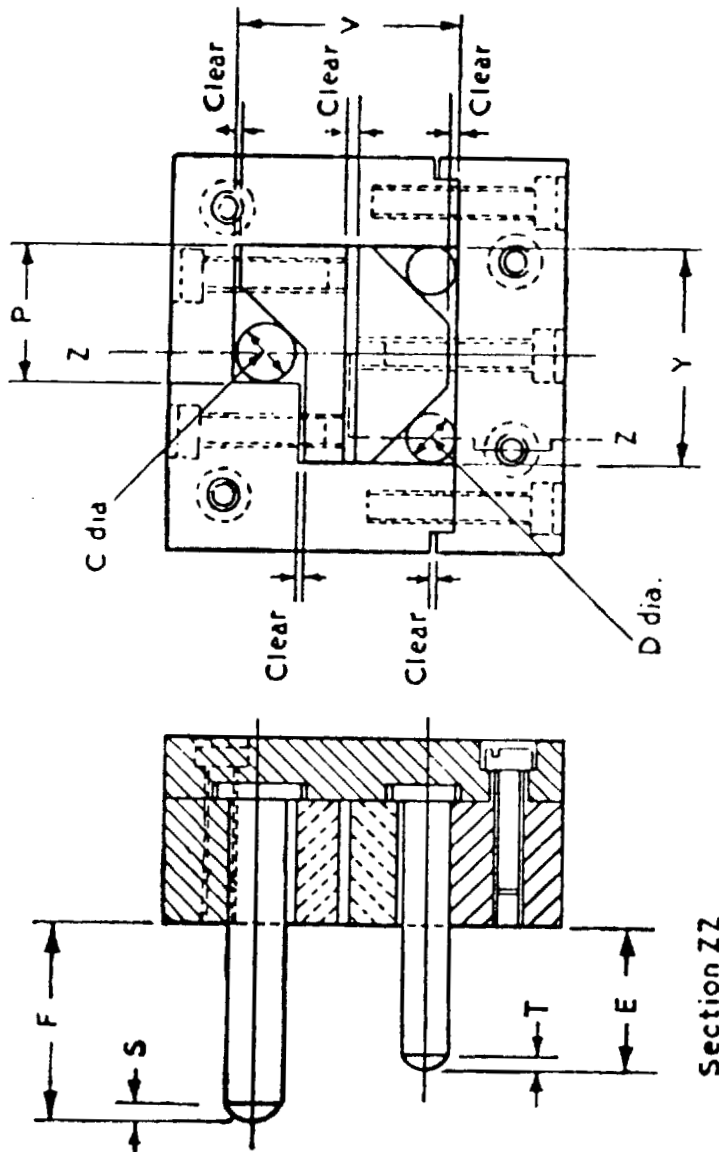

Fig. 4. Maximum 'GO' gauge for socket-outlet



TABLE 21. MAXIMUM 'GO' GAUGE FOR SOCKET-OUTLET

Rating	V	Y	C	D	E	F	$P = \frac{Y+C}{2}$	S	T
amps.	in.	in.	in.	in.	in.	in.	in.	in.	in.
2	0.670 6	0.717 0	0.201 0	0.141 0	0.541 0	0.666 0	0.459 0	0.062	0.046
5	1.036 6	0.957 0	0.279 0	0.201 0	0.666 0	0.853 0	0.618 0	0.078	0.062
15	1.325 3	1.285 0	0.344 0	0.279 0	0.853 0	1.166 0	0.814 5	0.093	0.078
30	1.737 9	1.756 0	0.376 0	0.313 0	1.166 0	1.478 0	1.066 0	0.109	0.093
Tolerance	+0.000 3 -0.000 0	+0.000 3 -0.000 0	+0.000 0 -0.000 3	+0.000 0 -0.000 3	+0.000 0 -0.000 5	+0.000 0 -0.000 5	+0.000 2 -0.000 0	+0.010 -0.000	+0.010 -0.000

NOTE 1. The drawings are not intended to be mandatory regarding details of construction.  
 NOTE 2. The radiused ends of the pin portions of the gauge are to be part of a sphere.

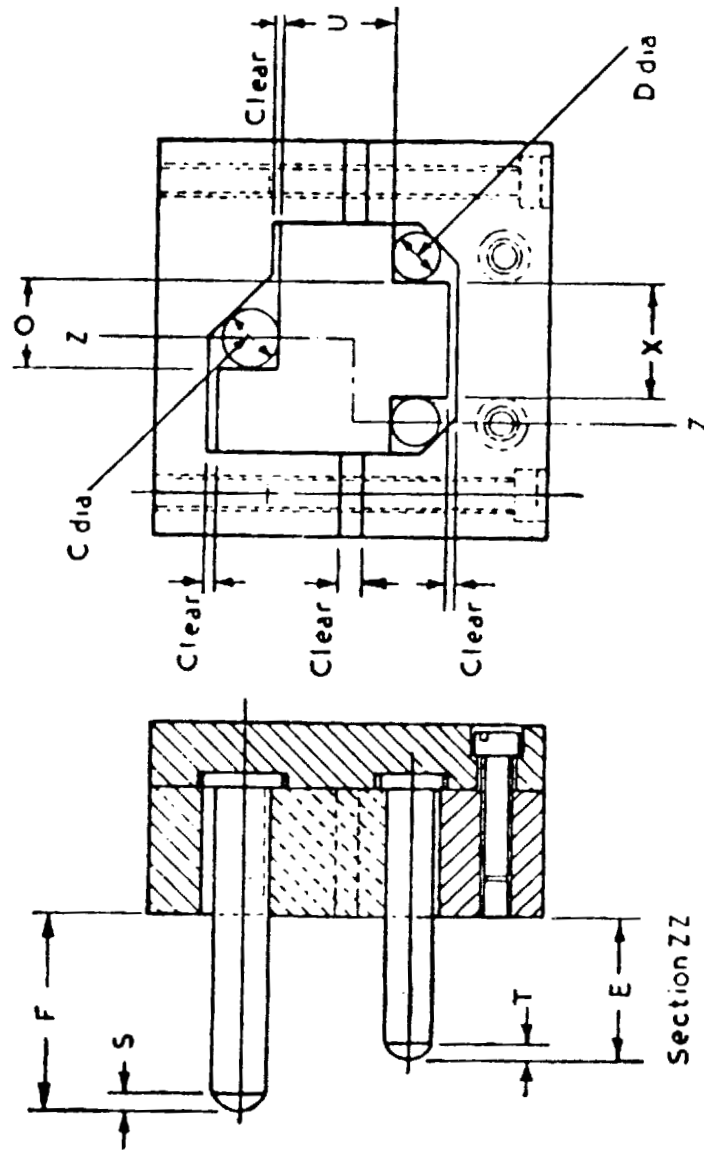

Fig. 5. Minimum 'GO' gauge for socket-outlet

TABLE 22. MINIMUM 'GO' GAUGE FOR SOCKET-OUTLET

Rating	U	X	C	D	E	F	$O = \frac{X+C}{2}$	S	T
amps.	in.	in.	in.	in.	in.	in.	in.	in.	in.
2	0.3166	0.4230	0.2010	0.1410	0.5410	0.6660	0.3120	0.062	0.046
5	0.5446	0.5430	0.2790	0.2010	0.6660	0.8530	0.4110	0.078	0.062
15	0.6903	0.7150	0.3440	0.2790	0.8530	1.1660	0.5295	0.093	0.078
30	1.0369	1.1180	0.3760	0.3130	1.1660	1.4780	0.7470	0.109	0.093
Tolerance	+0.0000 -0.0003	+0.0000 -0.0003	+0.0000 -0.0003	+0.0000 -0.0003	+0.0000 -0.0005	+0.0000 -0.0005	+0.0000 -0.0002	+0.010 -0.000	+0.010 -0.000

NOTE 1. The drawings are not intended to be mandatory regarding details of construction.

NOTE 2. The radiused ends of the pin portions of the gauge are to be part of a sphere.

**SUPPLEMENT No. 1 (1960) to  
BRITISH STANDARD 546 : 1950  
Two-pole and Earthing-pin Plugs, Socket-outlets, and  
Socket-outlet Adaptors for circuits up to 250 volts**

**SPECIFICATION FOR  
PLUGS MADE OF  
RESILIENT MATERIAL**

**PD 4007**  
UDC 621.316.541 : 678

**BRITISH STANDARDS INSTITUTION**

Incorporated by Royal Charter

2 PARK STREET, LONDON, W1A 2BS

Telex: 266934

Telephone: 01-629 9000

<http://www.china-gauges.com/>

Supplement No. 1 (1960) to  
B.S. 546 : 1950

THIS BRITISH STANDARD, having been approved by the Electrical Industry Standards Committee and endorsed by the Chairman of the Engineering Divisional Council, was published under the authority of the General Council on 30th December, 1960.

The Institution desires to call attention to the fact that this British Standard does not purport to include all the necessary provisions of a contract.

In order to keep abreast of progress in the industries concerned, British Standards are subject to periodical review. Suggestions for improvements will be recorded and in due course brought to the notice of the committees charged with the revision of the standards to which they refer.

A complete list of British Standards, numbering over 5000, indexed and cross-indexed for reference, together with an abstract of each standard, will be found in the Institution's Yearbook.

This standard makes reference to the following British Standards:

- B.S. 546. Two-pole and earthing-pin plugs, socket-outlets and socket-outlet adaptors for circuits up to 250 volts.
- B.S. 903. Methods of testing vulcanized rubber.
- B.S. 2719. Pocket type rubber hardness meters.  
Methods of use and calibration tests.

*British Standards are revised, when necessary, by the issue either of amendment slips or of revised editions. It is important that users of British Standards should ascertain that they are in possession of the latest amendments or editions.*

The following B.S.I. references relate to the work on this standard:  
Committee references L1E/4, F1E/4/2  
Draft for comment A (ELE) 4403

**CO-OPERATING ORGANIZATIONS**

The Electrical Industry Standards Committee under whose supervision this British Standard Supplement was prepared, consists of representatives from the following Government departments and scientific and industrial organizations:

- \*Admiralty
- \*Air Ministry
  - Associated Offices' Technical Committee
- \*Association of Consulting Engineers (Incorporated)
- \*Association of Supervising Electrical Engineers
- \*British Electrical and Allied Industries Research Association
- \*British Electrical and Allied Manufacturers' Association
  - British Electrical Development Association
  - British Railways, The British Transport Commission
  - Cable Makers' Association
- \*Crown Agents for Oversea Governments and Administrations
  - Electric Lamp Industry Council
- \*Electric Light Fittings Association
- \*Electrical Contractors' Association (Incorporated)
  - Electrical Contractors' Association of Scotland
- \*Electricity Council, Generating Board and the Area Boards in England and Wales
  - Electronic Engineering Association
  - Engineering Equipment Users' Association
  - Independent Cable Makers' Association
- \*Institution of Electrical Engineers
- \*Ministry of Aviation
- \*Ministry of Labour (Factory Inspectorate)
- \*Ministry of Power
- \*Ministry of Works
  - National Inspection Council for Electrical Installation Contracting
- \*National Physical Laboratory (D.S.I.R.)
  - Oil Companies Materials Association
- \*Post Office
  - Public Transport Association (Incorporated)
  - South of Scotland Electricity Board
  - War Office

The Government departments and scientific and industrial organizations marked with an asterisk in the above list, together with the following, were directly represented on the committee entrusted with the preparation of this standard:

- British Plastics Federation
- Conduit Fittings Manufacturers' Association
- Electrical Association for Women
- E.D.A. Testing House
- Fire Offices Committee
- Lloyds Register of Shipping
- National Union of Manufacturers
- Women's Advisory Committee of the B.S.I.

Supplement No. 1 (1960) to  
B.S. 546 : 1950

## BRITISH STANDARD SPECIFICATION FOR PLUGS MADE OF RESILIENT MATERIAL

### FOREWORD

This supplement has been prepared to cover plugs made substantially of rubber or other suitable resilient material which are not included in the main specification.

It includes material requirements and tests designed to ensure that such plugs shall be manufactured to adequate standards of quality.

In B.S. 546 the provision of shutters is not mandatory and many surface mounted socket-outlet covers have dimensions which only prevent overhang by a small margin of interference.

Plugs complying with this supplement may have a slight degree of flexibility of mounting of all contact pins, but they will have sufficient rigidity to render overhang of any plug in any socket-outlet of the same rating difficult to achieve without the user being aware that misuse by incorrect insertion is being attempted.

### SPECIFICATION

#### SCOPE

1. This supplement relates to 2 ampere, 5 ampere, 15 ampere and 30 ampere plugs, fused or unfused, in which the base and cover, or either of these components, are constructed of rubber or other suitable resilient material.

#### DEFINITIONS

2. In addition to the definitions of Clause 2 of B.S. 546, the following definitions have been adopted for the purposes of this supplement:

*a. Rubber.* The word rubber, where used, refers to mouldings made partly or entirely of rubber or other suitable resilient material which will meet the requirements and tests of this supplement.

*b. Overhang.* The term overhang defines the condition arising when a multi-pin plug is inserted into a socket-outlet in such a way that at least one pin can enter a current-carrying socket-contact while the other pin or pins are exposed.

#### GENERAL REQUIREMENTS

3. Plugs conforming to this supplement shall, unless otherwise specified, comply with the following Clauses of B.S. 546:



Section Two. General Requirements. Clauses 3 to 12.

Section Three. Special requirements for plugs. Clauses 13 and 17 to 19.

Section Six. Marking. Clause 30.

Section Seven. Sampling tests. Clauses 31 to 36.

Section Eight. Type tests. Clauses 37 to 39.

Section Nine. Gauges. Clause 41. 'go' gauge for plug.

For the purpose of this supplement, the following amendments to the clauses of B.S. 546 indicated are applicable:

*Clause 12, Materials.*

Where the base and cover of the plug, or either of these components, are constructed of rubber, as defined in Clause 2 and specified in Clause 4 of this supplement, then the requirements of Clause 12 of B.S. 546 for the base and cover shall not apply to such components.

*Clause 35, Insulation resistance.*

Clause 13, 'Insulation resistance test' of this supplement replaces Clause 35 of B.S. 546 for plugs having live metal in contact with rubber.

#### MATERIALS

4. Rubber, when used for the cover or base shall be free from blisters, cracks, embedded foreign matter and other physical properties and defects likely to affect insulating and mechanical protecting properties and shall have a hardness not less than 85 British Standard degrees when tested in an ambient temperature of  $20^{\circ}\text{C} \pm 5^{\circ}\text{C}$ .

NOTE. The hardness may be checked by a meter specified in B.S. 2719, 'Pocket type rubber hardness meters. Methods of use and calibration tests'. Attention is also drawn to the requirements of B.S. 903, 'Methods of testing vulcanized rubber'.

#### CONSTRUCTION OF PLUGS

5. *a. General.* Plugs shall be so designed and constructed that they cannot readily be deformed to allow access to live parts, nor shall it be possible for separated metal parts to be brought into contact with each other. The construction of the plug shall be such as to provide the user with adequate protection against shock. The plug shall be sufficiently strong to resist mechanical damage under normal service conditions and shall comply with the 'Plug pin deflection test' specified in Clause 15 of this supplement.

*b. Plugs with integral flexible cord.* Where a flexible cord is moulded integrally with a plug, the size of the flexible cord shall be appropriate to the current rating of the plug. Such a plug is not subject to the provisions of Clause 18 of B.S. 546.

*c. Fused-plugs with integral flexible cord.* If a flexible cord is moulded integrally with a fused plug, the current rating of the fuse appropriate to the flexible cord shall be clearly marked on the plug.



Supplement No. 1 (1960) to  
B.S. 546 : 1950

PRECAUTIONS AGAINST ACCIDENTAL CONTACT

6. No part of the current-carrying pins, line or neutral shall be less than the minimum distance given in Table 1 from the periphery of the face of the plug measured when the plug is inserted into the appropriate socket outlet as far as the first point of contact of the current carrying pins.

TABLE 1

Current rating	Minimum distance
amps	inches
2	0.250
5	0.312
15	0.375
30	0.500

PLUG PINS

7. Plug pins shall be substantially cylindrical in form, and shall have radiused ends to facilitate entry into corresponding socket outlets. They shall not be split or slotted. The dimensions shall be as given in Table 7 of B.S. 546.

CONSTRUCTION OF PLUG PINS AND TERMINALS

8. Each plug pin of a non-fused plug, each earthing plug pin, and each neutral plug pin of a fused plug, shall be formed in one piece with the fixed part of its terminal.

Each terminal shall be of substantial construction, and the terminals of a non-fused plug, and the earthing terminal and the neutral terminals of a fused plug, shall each provide for clamping and securing of its flexible conductor so that efficient electrical connection is made directly with an integral part of the plug pin.

That contact for the fuse-link which is connected to the line terminal of a fused plug shall be formed in one piece with the fixed part of the terminal or connected to it in such a way that it cannot work loose under normal service conditions, and the other contact shall be similarly connected to the corresponding plug pin. The line terminal shall also provide for clamping and securing of the conductor so that efficient electrical connection is made with the contact for the fuse-link.

If the plug pins are removable from the plug base, the pin and/or the plug base shall be so designed that it is impossible to assemble them in such a way that the fuse is connected to the neutral terminal.

3

'When pillar terminals are used they shall either:

a) meet the requirements given in Table 9 of BS 546, and have cheese headed clamping screws long enough under the head to extend to the far side of the conductor holes and with slightly rounded ends to minimize damage to conductors; or

b) meet the requirements given in Table 9a of BS 546. Terminal screws used in making electrical connections shall have root areas not less than that of the appropriate screws in Table 9a of BS 546 and shall withstand the minimum torques given in that table. If ISO metric screws are used, they shall comply with BS 3643.'

**CONNECTION BETWEEN COVER AND BASE OF PLUG**

9. The plug cover and base shall be firmly secured to one another. Any screws or other devices used for securing the plug cover and the plug base shall only be accessible from the under side of the base of the plug.

**AGEING**

10. Plugs shall be sufficiently resistant to ageing as proved by the type test specified in Clause 14 of this supplement.

**MARKING**

11. Plugs complying with this supplement if marked in any way identifying them with it, shall be marked ' B.S. 546/A '.

For the marking of fused plugs with integral flexible cord, attention is drawn to the requirements of Clause 5c.

**TESTS**

12. In addition to the tests of Sections Seven and Eight of B.S. 546, the tests specified in Clauses 14 and 15 of this supplement shall be type tests.

**INSULATION RESISTANCE TEST**

13. Every plug having live metal in contact with rubber shall pass the following tests in lieu of the test specified in Clause 35 of B.S. 546, before being subjected to a high voltage test as required by Clause 36.

The insulation resistance between line and neutral terminals and earth terminal shall be not less than 50 megohms and the test shall be made at not less than 500 volts d.c. applied for a sufficient length of time for the reading of the measuring instrument to become steady, the supply being obtained from an independent source or generated in the measuring instrument.

**AGEING TEST**

14. An accelerated ageing test is made in an atmosphere having the composition and pressure of the ambient air. The samples are suspended freely in a heating cabinet in which the air is renewed by natural draught. They are kept at a temperature of  $70^{\circ}\text{C} \pm 2^{\circ}\text{C}$  for 240 hours.

It is recommended that an electrically heated cabinet is used. The temperature may be measured by means of a thermometer. The natural air circulation may be provided by holes in the walls of the cabinet.

Supplement No. 1 (1960) to  
B.S. 546 : 1950

After the test and after samples have been allowed to cool to the ambient temperature, the samples shall comply in all respects with the other requirements and the test Clauses 13 and 15 of this supplement.

PLUG PIN DEFLECTION TEST

15. Plugs shall be tested for deflection of plug pins under the following conditions of test:

A suitable form of apparatus is shown in Fig. 1 of this supplement.

The test shall be carried out in an ambient temperature of  $20^{\circ}\text{C} \pm 5^{\circ}\text{C}$ .

The plug shall be clamped in a mounting block by means of any two of the plug pins in such a manner as to ensure the face of the plug from which the plug pins project is supported and in contact with a corresponding flat surface on the mounting block. The back of the plug shall not be supported or come into contact with the fixture. The axes of the clamped plug pins shall be horizontal.

Provision shall be made in the mounting block for the application to the remaining pin of a deflecting force of 1 lb applied at a distance of 1 inch from the face of the plug and at right angles to the axis of the pin under test.

The deflection of the pin from the horizontal axis is measured at 1 inch from the face of the plug.

The mounting block shall ensure that the axis passing through the pin under test and each of the clamped pins in turn shall be in the same vertical plane as the applied deflecting force with the pin under test disposed in the lower position. Two measurements of deflection shall be recorded with either clamped pin in the upper position.

The deflection of each pin shall be the arithmetical mean of the two measurements.

The deflection of the plug pin shall not exceed 0.5 times the diameter of the pin under test.

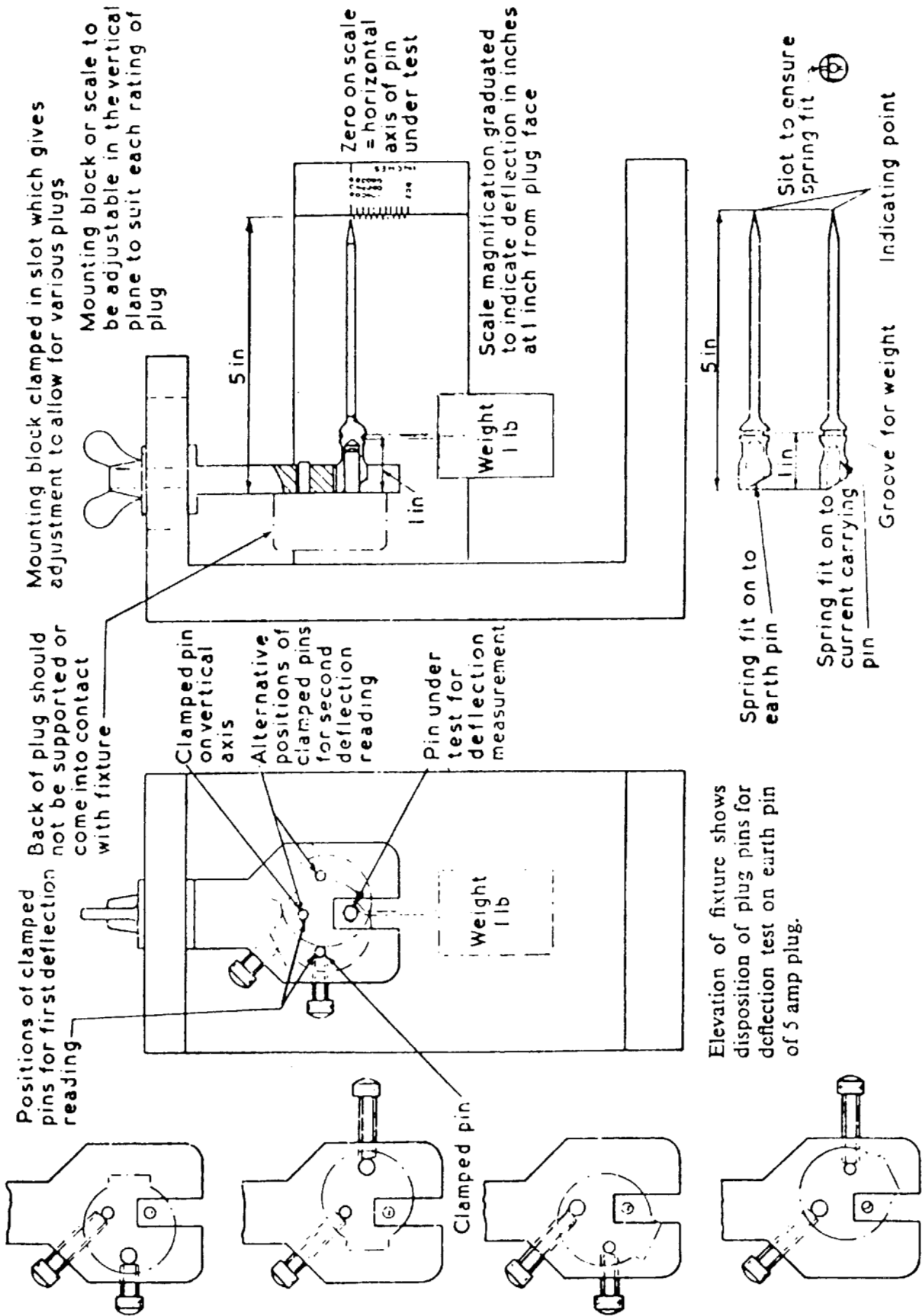

Indicators manufactured from material of negligible weight such as aluminium.

Fig. 1. Plug pins deflection test apparatus (B.S. 546 Plugs).

**SUPPLEMENT No. 2 (1987) to  
BRITISH STANDARD 546 : 1950  
Two-pole and Earthing-pin Plugs, Socket-outlets  
and Socket-outlet Adaptors**

**SPECIFICATION FOR  
SWITCHED SOCKET-OUTLETS**

Supplement No. 2 (1987)  
to B.S. 546 : 1950

## FOREWORD

This supplement has been prepared to cover fixed socket-outlets complying with B.S. 546 which incorporate an integral switch in their construction, for use in a.c. circuits only. Such accessories, although in general use, are not covered by the scope of B.S. 546 as written.

## SPECIFICATION

### SCOPE

1. This supplement relates to 2 ampere, 5 ampere, 15 ampere and 30 ampere socket-outlets which contain a switch connected between the current carrying contact(s) of the socket-outlet and the relevant supply terminal(s), for use in a.c. circuits only.

### DEFINITIONS

2. In addition to the definitions of Clause 2 of B.S. 546 : 1950, the following definitions apply:

*a. Switched socket-outlet.* A socket-outlet with an associated switch to disconnect the supply to the line socket contact or to both line and neutral socket contacts.

*b. Actuating member.* That part which is moved, e.g. pulled, pushed or turned by the user to operate the switch mechanism.

### GENERAL REQUIREMENTS

3. Switched socket-outlets conforming to this supplement shall comply with all the Clauses of B.S. 546 relating to socket-outlets except where stated below:

*Clause 8, Engagement of pins and contacts.* The following additional requirement applies.

Any part of the actuating member in any position it may occupy shall not lie within the circle having a radius given in Table 3. For 15 ampere switched socket-outlets the radius of engagement circle as shown in Table 3 shall be reduced to 1.160 inches.

Compliance shall be checked by inspection and measurement.

*Clause 11, Clearance and creepage.* The following additional requirement applies.

The minimum clearance between switch contacts in the open position shall be 0.047 inches (1.2 millimetres).

Compliance shall be checked by inspection and measurement.



*Clause 21, Construction of socket contacts and terminals.*

Clause 4 'Terminals' of this supplement replaces Clause 21 of B.S. 546.



*Clause 32, Interchangeability.* The following additional note applies.

NOTE. For switched socket-outlets, although the switch actuating member is outside the radius of engagement (see Clause 8) it may still prevent full engagement of the gauge specified in Clause 41: in this circumstance the projecting switch actuating member may be removed.

*Clause 33, Effectiveness of contact.* The following additional requirement applies.

For switched socket-outlets the voltage drop in a switched pole measured from the terminal of the switched socket-outlet to the corresponding plug pin shall not exceed 60 millivolts at rated current.

*Clause 35, Insulation resistance.* The following additional requirement applies.

Across switch contacts with the switch open (for switched socket-outlets) the value shall be not less than 50 megohms.

*Clause 36, High-voltage test.* The following additional requirement applies.

For switched socket-outlets, switches shall be tested in the closed position, followed by tests with the switch contacts in the open position.

*Clause 38, Current-breaking.* The following additional requirement applies.

Switched socket-outlets shall be tested in a substantially non-inductive a.c. circuit as follows:

a. For socket contacts, as described in Clause 38 as modified above.

b. For switch contacts, with the switched socket-outlet plates in position and with all metal parts not in contact with live contacts connected to the earthed pole of the test circuit, the switch shall make and break the specified current in a substantially non-inductive a.c. circuit ten times in succession at intervals of 30 seconds. After the tests the switched socket-outlet shall be in a serviceable condition.

*Clause 41, 'Go' gauges for plugs and socket-outlets.* The following additional note applies.

NOTE. When checking the requirements of Clause 41, providing the switch actuating member lies outside the radius of engagement circle specified in Table 3, the projecting switch operating member may be removed.



**TERMINALS**

4. Terminals shall be of such design and dimensions that under normal conditions of use they do not overheat.

In pillar-type terminals the screws shall be of sufficient length to ensure that the screws or intermediate clamping members extend to the far side of the terminal hole. The screws and the surface on which the conductor is clamped shall be so shaped that the conductor may be securely held and not unduly deformed. The sizes of the conductor hole and the clamping screw shall be such that the clearance between the sides of the major diameter of the clamping screw and the conductor hole does not exceed 0.6 millimetres.

Terminals, unless of a form which will prevent conductor strands from spreading, shall be fitted with special washers or other suitable devices to control such spreading and shall be suitable for repeated use.

Terminals shall accept two conductors appropriate to the rated current of the accessory, except for a 30 ampere switched socket-outlet which shall accept a minimum of one appropriate size conductor. The clearance of any live part of the terminal from any non-current carrying metal part shall comply with the dimensions given in Clause 11 of B.S. 546 when the terminal is fitted with the maximum size or number of conductors which it will accommodate when effectively clamped.

Terminal screws used in making electrical connections shall have a root area not less than that of the appropriate screws in Table A of this supplement. The terminals and screws shall withstand the torques detailed in Table A of this supplement. If ISO metric screws are used they shall be in accordance with B.S. 3643.

Pillar terminals may, as an alternative, meet the requirements given in Clause 21 and Table 12 of B.S. 546 : 1950.

Compliance shall be checked by inspection and the temperature rise test of Clause 7.

**TABLE A. TERMINAL SCREWS : SIZE AND TORQUE**

Current rating of accessory	Minimum nominal diameter of ISO metric screws and torques							
	Single screw with head		Two screws with head		Single screw without head*		Two screws without head*	
	Size	Torque	Size	Torque	Size	Torque	Size	Torque
amp.	mm	N·m	mm	N·m	mm	N·m	mm	N·m
Up to 5	2.5	0.4	—	—	2.5	0.2	—	—
Over 5 and up to 15	3	0.5	2.5	0.4	3	0.25	2.5	0.2
Over 15 and up to 20	3.5	0.8	2.5	0.4	3.5	0.4	2.5	0.2
Over 20 and up to 30	4	1.2	3	0.5	4	0.7	3	0.25

\* These values only apply if the screw, when tightened, does not protrude from the hole, otherwise the values for screws with head apply.

### PRECAUTIONS AGAINST REVERSAL OF POLARITY

5. Internal connections shall be so arranged that correct polarity is maintained.

Compliance shall be checked by inspection.

### SWITCH ACTION

6. The actuating member of a switch shall not remain at rest in the off position whilst the switch contacts remain closed.

The actuating mechanism shall be so constructed that when operated the switch can remain only in a position giving adequate contact or adequate separation of the contacts.

Switches shall be so constructed that undue arcing cannot occur when the switch is operated slowly.

Switches shall disconnect at least the supply to the line socket contact.

Double pole switches shall make or break each pole with one movement of the actuator.

Compliance shall be checked by inspection and by the following test.

Following the test described in Clause 38, the circuit is broken a further 10 times, each time moving the actuating member by hand over a period of 2 seconds in a manner such as to attempt to stop the moving contact in an intermediate position causing arcing. The actuating member shall be released after 2 seconds and any arcing shall cease.

### TEMPERATURE RISE

7. Switched socket-outlets shall not attain excessive temperatures in normal use.

Compliance shall be checked by a temperature rise test at rated current with the switched socket-outlet mounted and wired as in normal use in surroundings free from external drafts. The temperature rise of any terminal shall not exceed 35 K when measured at 4 hours and 8 hours after the commencement of the test.

For the purpose of the test, wiring shall be of PVC insulated (non-sheathed) cable with a cross-sectional area of 1 square millimetre (up to 10 ampere) or 2.5 square millimetres (over 10 amperes and up to 16 amperes) or 6 square millimetres (over 16 amperes and up to 30 amperes). The cables shall be bunched together for a distance of 1 metre from the cable entry which shall be plugged to prevent the free circulation of air.

The load shall be connected using a non-fused plug complying with B.S. 546 fitted with 1 metre of appropriately sized cord complying with Table 16 of B.S. 6500 : 1984.

## ELECTRICAL ENDURANCE OF SWITCHES

### 8. The electrical endurance of switches shall be adequate.

Compliance shall be checked by testing the capacity to make and break rated current at 250 volts, 15,000 times (30 000 movements) in a substantially non-inductive a.c. circuit at a rate of six complete cycles per minute at regular intervals. The periods during which the switches are ON and OFF shall be approximately equal.

Metallic switched socket-outlet plates and all non-current-carrying metal parts that are normally exposed when the switched socket-outlet plate is not in position and that may become live in the event of failure of insulation, shall be connected to the earthed pole of the test circuit. The connection to earth may be through a fine wire fuse.

The means used for operating the switches shall be such as to move the actuating member at a speed of approximately 12 inches (305 millimetres) per second both in making and in breaking the circuit and shall be so disposed in relation to the actuating member that the normal action of the mechanism as a whole is not interfered with in any way.

At the end of the test the switch shall be capable of making and breaking its rated current at rated voltage and furthermore the voltage drop across each pole at rated current shall not exceed 75 millivolts. In addition the switch shall comply with the requirements of Clauses 35 and 36 of B.S. 546 : 1950 as modified in Clause 3 of this supplement. However, the values of insulation resistance shall be reduced from 100 megohm to 5 megohm and 50 megohm to 2 megohm respectively.

## MOISTURE RESISTANCE

### 9. Switched socket-outlets shall be proof against humid conditions which may occur in normal use.

Compliance shall be checked by the following humidity treatment.

Vitrified ceramic material, which after 24 hours immersion in water has not increased in weight by more than 0.5 per cent after all the moisture has been removed from its surface, shall not be subjected to further tests, providing the resistance to water of the material does not depend on glaze or varnish.

To suit the ambient conditions at the time of test, a convenient temperature  $T$  (in °C) between 20 °C and 30 °C, shall be chosen as a reference temperature. The samples shall be brought to a temperature of between  $T$  and  $T + 4$  °C and placed in a humidity cabinet containing air with a relative humidity maintained between 91 per cent and 95 per cent. The temperature of the air at all positions within the cabinet where samples can be placed shall be kept within 1 °C of the chosen value  $T$ .

The sample shall be kept in the cabinet for 48 hours.

NOTE. In most cases samples may be brought to the chosen reference temperature by keeping them at this temperature for at least 4 hours before the humidity treatment.

A relative humidity of between 91 per cent and 95 per cent can be obtained by placing in the humidity cabinet a saturated solution of potassium nitrate ( $\text{KNO}_3$ ) or sodium sulphate ( $\text{Na}_2\text{SO}_4$ ) in water having sufficiently large contact surface with the air.

In order to achieve the specified conditions within the cabinet it is necessary to ensure constant circulation of the air within the cabinet and, in general, to use a cabinet which is thermally insulated.

Immediately after this treatment, samples shall not show any appreciable damage, within the meaning of the specification, and, in addition, the switch shall comply with the requirements of Clause 35 and Clause 36 which shall be made in the humidity cabinet or in a room where the specified temperature is maintained. However, the values of insulation resistance shall be reduced from 100 megohm to 5 megohm and from 50 megohm to 2 megohm respectively.

AMD 5809

**Amendment No. 6**  
**published and effective from 23 December 1987**  
**to BS 546 : 1950**

Two-pole and earthing-pin plugs, socket-outlets  
 and socket-outlet adaptors

**Revised and additional text**

**Table 7. Dimensions of plug pins** (as amended by Amendment No. 4)

In column 5 delete:

'Tolerance  
 on all  
 projections  
 $\left. \begin{array}{l} + 0.030 \\ - 0.005 \end{array} \right\} \text{ in.}'$

and substitute:

'Tolerance  
 on projections  
 2 and 30 amp.  
 rating  
 $\left. \begin{array}{l} + 0.041 \\ - 0.005 \end{array} \right\} \text{ in.}'$

5 and 15 amp.  
 rating  
 $\left. \begin{array}{l} + 0.030 \\ - 0.005 \end{array} \right\} \text{ in.}'$

**New supplement No. 2.** Insert the attached new supplement at the end of the existing text.

AMD 6144

**Amendment No. 7**  
**published and effective from 31 January 1989**  
**to BS 546 : 1950**

Two-pole and earthing-pin plugs, socket-outlets  
 and socket-outlet adaptors

**Revised text**

**Clause 30. Marking.** In paragraph 1 delete lines 1 to 3 and substitute the following.

‘**30.** All plugs and socket-outlets and socket-outlet adaptors shall be clearly and indelibly marked with the manufacturer’s name or identifying mark, the number of this British Standard, i.e. BS 546\*, and, in addition, with the following:—’

At the foot of the page insert the following footnote.

‘\*Marking BS 546 on or in relation to a product represents a manufacturer’s declaration of conformity, i.e. a claim by or on behalf of the manufacturer that the product meets the requirements of the standard. The accuracy of the claim is therefore solely the responsibility of the person making the claim. Such a declaration is not to be confused with third party certification of conformity, which may also be desirable.’

**Supplement No. 2 (1987)**

**Clause 10. Marking.** In paragraph 1, at the end of the list, insert the following.

‘f. The number of this British Standard, i.e. BS 546\*.’

At the foot of the page insert the following footnote.

‘\*Marking BS 546 on or in relation to a product represents a manufacturer’s declaration of conformity, i.e. a claim by or on behalf of the manufacturer that the product meets the requirements of the standard. The accuracy of the claim is therefore solely the responsibility of the person making the claim. Such a declaration is not to be confused with third party certification of conformity, which may also be desirable.’



## Amendment No. 8

published and effective from 15 May 1999

to BS 546 : 1950

Two-pole and earthing-pin plugs, socket-outlets and socket-outlet adaptors

### Revised text

#### Title

Add the following text to the end of the title.

# FOR AC (50-60 Hz) CIRCUITS UP TO 250 V

AMD 8914/May 1999

#### Clause 3

Delete the paragraph entirely and substitute the following.

'Accessories shall be so designed and constructed that in normal use their performance is reliable and without danger to the user or to the surroundings. Accessories complying with this standard shall be capable of meeting all the relevant tests specified in this standard.

The gauges illustrated in Figures 2, 3, 4 and 5 shall be considered to comply with the dimensional requirements if the results of the measured values are within the specified dimensions and the uncertainty of measurement at not less than 95 % confidence level does not exceed  $\pm 0.0002$  in/0.005 mm.'

AMD 8914/May 1999

#### Clause 12

Delete the clause, including Table 5, and substitute the following.

#### '12. Materials

**12.1** All materials shall comply with the requirements given in **12.2** to **12.8**, where relevant.

**12.2** Parts made of insulating material which might be exposed to thermal stresses due to electric effects, and deterioration of which might impair the safety of the accessory, shall not be unduly affected by abnormal heat and fire.

Except for parts made of ceramic material and small components such as washers, compliance shall be checked by the test described in **12.4**.

**12.3** Current-carrying parts shall be made of brass, copper, phosphor-bronze or other material at least equivalent with regard to its conductivity, resistance to abrasion and resistance to corrosion.

Compliance shall be checked by the tests described in **12.6**, **33** and **39**.

<http://www.china-gauges.com/>

**12.4** The glow-wire test shall be performed in accordance with clauses **4** to **10** of BS 6458 : Section 2.1 : 1984, and at the test temperature given in Table 5.

**TABLE 5. APPLICATION OF GLOW-WIRE TEST**

Part	Glow-wire temperature	
	Portable accessories	Fixed accessories
	°C	°C
Parts necessary to retain current carrying parts in position	750 ± 10	850 ± 15
Parts not necessary to retain current carrying parts in position (although they may be in contact with them)	650 ± 10	650 ± 10

NOTE 1. If the test specified is required to be made at more than one place on the same specimen, it is essential that care is taken to ensure that any deterioration caused by previous tests does not affect the result of the test to be made.

NOTE 2. Small parts unlikely to be subjected to abnormal heat and the failure of which to pass these tests would not materially affect the safety of the accessory are not subjected to this glow-wire test.

The glow-wire test shall be applied to ensure that an electrically heated test wire under defined test conditions does not cause ignition of insulating parts or to ensure that a part of insulating material, which might be ignited by the heated test wire under defined conditions, has a limited time to burn without spreading fire by flame or burning parts or droplets falling down from the tested part onto a pinewood board covered with tissue paper.

The test specimen shall be either:

- a) a complete accessory; or,
- b) if the test cannot be made on a complete accessory, a suitable part may be cut from one for the purpose of the test.

The test shall be made on one specimen. In case of doubt, the test shall be repeated on two further specimens.

The test shall be made applying the glow wire once.

The specimen shall be positioned during the test in the most unfavourable position of its intended use (with the surface tested in a vertical position). The tip of the glow-wire shall be applied to the specified surface of the specimen, taking into account the conditions of the intended use under which a heated or glowing element may come into contact with the specimen.

The specimen shall be regarded as having passed the glow-wire test if:

- 1) there is no visible flame and no sustained glowing; or
- 2) flames and glowing at the specimen extinguish within 30 s after the removal of the glow-wire.

There shall be no ignition of the tissue paper nor scorching of the board.



**12.5** Current carrying parts of copper alloy containing less than 80% of copper, and which are press formed or produced in a manner which could induce excessive internal stresses, shall be resistant to failure in use due to brittleness, when tested in accordance with **12.6**.

**Warning.** Refer to the supplier's health and safety data sheets for the precautions which are to be taken for the safe use of mercurous nitrate, nitric acid, ammonium chloride, alkalis and organic solvents.

NOTE. Attention is drawn to the Control of Substances Hazardous to Health (COSHH) Regulations 1988 [1].

**12.6** The test specimen shall be degreased in a suitable alkaline degreasing solution or organic solvent, then immersed in an aqueous solution of mercurous nitrate containing 10g of  $\text{Hg}_2(\text{NO}_3)_2$  and 10 ml of  $\text{HNO}_3$  (relative density 1.42) per l of solution for  $(30 \pm 1)$  min at a temperature of  $(20 \pm 5)$  °C.

After the treatment, the test specimen shall be washed in running water, and any excess mercury shall be wiped off.

The sample shall immediately be examined visually.

There shall be no cracks visible with normal or corrected vision without additional magnification.

**12.7** Ferrous parts shall be adequately protected against rusting. Compliance is checked by the test of **12.8**.

**12.8** The test specimens shall be degreased in a suitable alkaline degreasing solution or organic solvent.

The specimens shall then be immersed for  $(10 \pm 0.5)$  min in a 10% solution of ammonium chloride in water, at a temperature of  $(20 \pm 5)$  °C.

Without drying, but after shaking off any drops, the specimens shall be placed for  $(10 \pm 0.5)$  min in a box containing air saturated with moisture, at a temperature of  $(20 \pm 5)$  °C.

The specimens shall be dried for at least 10 min in a heating cabinet at a temperature  $(100 \pm 5)$  °C.

NOTE 1. Traces of rust on sharp edges, and any yellowish film removable by rubbing are ignored.

NOTE 2. For small helical springs and the like, and for parts exposed to abrasion, a layer of grease may provide sufficient protection against rusting. Such parts are only subjected to test if there is doubt about the effectiveness of the grease film, and the test should then be made without previous removal of the grease.'

AMD 8914/May 1999

## Clause 16

In paragraph 2, line 6, delete 'shall' and substitute 'may'.

Delete paragraph 5 and substitute the following.

'When pillar terminals are used they shall either:

a) meet the requirements given in Table 9, and have cheese-headed clamping screws long enough under the head to extend to the far side of the conductor holes and with slightly rounded ends to minimize damage to conductors; or

b) meet the requirements given in Table 9a. Terminal screws used in making electrical connections shall have a root area not less than that of the appropriate screws in Table 9a and shall withstand the minimum torques given in Table 9a. If ISO metric screws are used, they shall comply with BS 3643.

<http://www.china-gauges.com/>

**TABLE 9a. PLUG TERMINAL SCREWS: SIZE AND TORQUE**

Current rating of plug	Minimum thickness of the wall where the clamping screw passes through	Minimum nominal diameter	Minimum torque rating
amp.	mm	mm	Nm
2	1.4	2.5	0.4
5	1.6	3	0.5
15	3.2	3.5	0.8
30	4.8	4	1.2

The sizes of the conductor hole and the clamping screw shall be such that the clearance between the sides of the major diameter of the clamping screw and the conductor hole does not exceed 0.4 mm.'

AMD 8914/May 1999

Clause 21

Delete paragraph 3 and substitute the following.

'When pillar terminals are used they shall either:

a) meet the requirements given in Table 12, and have cheese-headed clamping screws long enough under the head to extend to the far side of the conductor holes and with slightly rounded ends to minimize damage to conductors; or

b) meet the requirements given in Table 12a. Terminal screws shall have the minimum root areas and shall withstand the minimum torques given in Table 12a. If ISO metric screws are used, they shall comply with BS 3643.

**TABLE 12a. SOCKET-OUTLET TERMINAL SCREWS: SIZE AND TORQUE**

Current rating of socket-outlet	Minimum nominal diameter and minimum torque rating of ISO metric screws							
	Single screw with head		Two screws with head		Single screw without head		Two screws without head	
	Size	Torque	Size	Torque	Size	Torque	Size	Torque
A	mm	Nm	mm	Nm	mm	Nm	mm	Nm
2	2.5	0.4	-	-	2.5	0.2	-	-
5	3	0.5	2.5	0.4	3	0.25	2.5	0.2
15	3.5	0.8	2.5	0.4	3.5	0.4	2.5	0.2
30	4	1.2	3	0.5	4	0.7	3	0.25

The sizes of the conductor hole and the clamping screw shall be such that the clearance between the sides of the major diameter of the clamping screw and the conductor hole does not exceed 0.6 mm.'

AMD 8914/May 1999

<http://www.china-gauges.com/>

**Clause 24**

Delete this clause entirely.

**AMD 8914/May 1999**

---

**Table 14**

Delete entirely.

**AMD 8914/May 1999**

---

**Clause 25**

Delete this clause entirely.

**AMD 8914/May 1999**

---

**Table 15**

Delete entirely.

**AMD 8914/May 1999**

---

**Clause 30**

In paragraph 1, delete lines 1 to 4 and substitute the following.

‘Plugs and socket-outlets and socket-outlet adaptors shall be legibly and durably marked with the following information which shall not be placed on screws, removable washers or other removable parts, or on parts intended for separate sale.

The name or trade mark of the manufacturer or responsible vendor.

The number of this British Standard, i.e. BS 546\*.

In addition, they shall be marked with the following.’

At the foot of the page, insert the following footnote.

\*Marking BS 546 : 1950 on or in relation to a product represents a manufacturer's declaration of conformity, i.e. a claim by or on behalf of the manufacturer that the product meets the requirements of the standard. The accuracy of the claim is solely the claimant's responsibility. Such a declaration is not to be confused with third-party certification of conformity.’

In the list headed ‘Plugs’, delete item *a.* entirely and substitute the following.

*a.* The terminals for the connection of line and neutral conductors shall be identified by their respective symbols L and N. The symbol used for the protective terminal shall be either  $\ominus$  (which is preferred) or  $\frac{\perp}{\ominus}$  which may be accompanied by the letter E.’

In the list headed ‘Socket-outlets’, delete items *a.* and *b.* and substitute the following.

*a.* The rated current in amperes.

*b.* The rated voltage, i.e. 250 volts.

*c.* Nature of supply, i.e. ~ (preferred) or a.c.

*d.* The terminals for the connection of line and neutral conductors shall be identified by their respective symbols L and N. The symbol used for the protective terminal shall be either  $\ominus$  (which is preferred) or  $\frac{\perp}{\ominus}$  which may be accompanied by the letter E.

NOTE. For the marking of the rated current and rated voltage of the socket outlet, figures may be used alone, the figures for the current rating being placed before or above that of the rated voltage and separated by a line.

If a symbol for nature of supply is used, it shall be placed next to the marking for rated current and rated voltage. Examples are as follows:

$$15A\ 250V\ a.c.\ \text{or}\ 15/250\ \sim\ \text{or}\ \frac{15}{250}\ \sim'$$

AMD 8914/May 1999

---

### Clause 33

In paragraph 1, line 1, delete the reference to page 23.

In paragraph 1, line 5, delete 'individual socket' and insert 'individual current carrying socket'.

Delete the note following paragraph 1.

Insert the following new paragraph after paragraph 1.

'The effectiveness of contact for metal components connected to an earth terminal of a socket-outlet shall be checked by the following test.

A current of  $(25 \pm 0.75)$  A, derived from an a.c. source, having a no-load voltage not exceeding 12 V, is passed for  $60 \begin{smallmatrix} +5 \\ 0 \end{smallmatrix}$  s and between the earthing terminal and a plug pin inserted in the earthing socket contact.

The resistance between the terminal and any other part shall not exceed  $0.05\ \Omega$ .'

AMD 8914/May 1999

---

### Clause 38

Delete the entire clause and substitute the following.

'The breaking capacity of socket contacts shall be adequate.

Socket-outlets or adaptors shall be connected and mounted as in normal use.

The socket contacts shall be capable of making and breaking a current 30 % in excess of their current rating, when tested in a substantially non-inductive a.c. circuit at  $275\ V \pm 5\ V$ . The plug and socket-outlet shall break the circuit 10 times in succession at intervals of approximately 30 seconds, a plug of the corresponding rating being withdrawn from the socket-outlet at a speed of approximately 150 mm per second immediately after insertion.

NOTE. For the purpose of this test, the fuse link, if any, may be replaced by a link of negligible impedance.

After the test, the socket-outlet shall be capable of satisfying the subsequent tests detailed in clauses 33 and 39.'

AMD 8914/May 1999

---

### Section nine

Delete the subtitle 'GO' GAUGES FOR PLUGS AND SOCKET-OUTLETS'.

Insert the following new clause 40a immediately before clause 41.

'**40a.** The gauges illustrated in figures 2, 3, 4 and 5 shall be considered to comply with the dimensional requirements if the results of the measured values are within the specified dimensions and the uncertainty of measurement at not less than 95 % confidence level does not exceed  $\pm 0.0002\ \text{in}/0.005\ \text{mm}$ .'

AMD 8914/May 1999

---

## Supplement No. 1 (PD 4007)

## Clause 3

In the third line, delete 'Section Two. General requirements. Clauses 3 to 6 and 8 to 12' and substitute 'Section Two. General Requirements. Clauses 3 to 12.'

Delete clause 6 including Table 1.

AMD 8914/May 1999

---

## Clause 8

Delete the final paragraph and substitute the following.

'When pillar terminals are used they shall either:

a) meet the requirements given in Table 9 of BS 546, and have cheese headed clamping screws long enough under the head to extend to the far side of the conductor holes and with slightly rounded ends to minimize damage to conductors; or

b) meet the requirements given in Table 9a of BS 546. Terminal screws used in making electrical connections shall have root areas not less than that of the appropriate screws in Table 9a of BS 546 and shall withstand the minimum torques given in that table. If ISO metric screws are used, they shall comply with BS 3643.'

AMD 8914/May 1999

---

## Supplement No. 2

## Clause 3

Delete the reference to 'Table 5, Materials for component parts', together with its accompanying text.

Delete the reference to 'Clause 30, Marking', together with its accompanying text.

## Clause 10

Delete this clause entirely

AMD 8914/May 1999

---